



IJEAST

INTERNATIONAL JOURNAL
OF ENGINEERING APPLIED SCIENCE
AND TECHNOLOGY



VOLUME : 2 ISSUE : 9 Print / Issue Publication Date: 25-Mar-2018



ISSN : 2455-2143



Indexed In



WWW.IJEAST.COM

editor@ijeast.com



COMPARATIVE STUDY OF DIFFERENT TRANSFORMERLESS BUCK-BOOST CONVERTERS

Jithin K Mathews

Department of Electrical & Electronics,
Mar Athanasius College of Engineering, Kothamangalam, Kerala, India

Annie P Ommen

Professor
Department of Electrical & Electronics Engineering,
Mar Athanasius College of Engineering, Kothamangalam, Kerala, India

Bindu Elias

Professor
Department of Electrical & Electronics Engineering,
Mar Athanasius College of Engineering, Kothamangalam, Kerala, India

Abstract—A comparative study of different buck-boost converters is aimed in this paper. The traditional buck-boost converter and KY buck-boost converter are compared with the new transformerless buck-boost converter. The new transformerless buck-boost converter's voltage gain is squared times that of the former and its output voltage polarity is positive. The two power switches of the new transformerless buck-boost converter operate synchronously. These advantages enable it to work in a wider range of positive output voltage. The output voltages for different duty ratios for new transformerless buck boost converter are compared with the other two buck-boost converters. They are also compared for their efficiencies. The simulations of these buck-boost converters are done using MATLAB/SIMULINK software. The hardware of the new transformerless buck-boost converter is also made. The control circuit is implemented using PIC16F877A.

Keywords— Buck-boost converter, KY converter

I. INTRODUCTION

Owing to energy crisis and global warming, Green energy is attracting more and more attention, resulting in the demand for the green energy, which produces less pollution on the environment. The green energy facilities include wind power, solar cells, fuel cells and so on. In many applications, because the above mentioned green energy facilities suffer from unstable and lower output voltages, high-voltage conversion converters play an important role in maintaining the output voltage at a constant value and boosting the low output voltages of the green power facilities to the high voltages which the loads need. For example, the traditional fuel cell system in a vehicle boosts 12V to 48V or 72V or more to drive the LED loads, the heating fans, sound system equipment and so on. Regarding the traditional non-isolated voltage-boosting

converters, such as the traditional boost converter and the buck-boost converter, their voltage gains are not high enough. Many applications require voltage bucking/boosting converters, such as portable devices, car electronic devices, etc. This is because the battery has quite large variations in output voltage, and hence, the additional switching power supply is indispensable for processing the varied input voltage so as to generate the stabilized output voltage.

A KY converter uses four switches. In order to reduce the number of power switches in KY converter, the KY converter and the SR buck converter, combined into a buck-boost converter, i.e., KY buck-boost converter or 2D converter, both use the same power switches.

By inserting an additional switched network into the traditional buck-boost converter, a new transformerless buck-boost converter is presented. The main merit of this new transformerless buck-boost converter is that its voltage gain is quadratic of the traditional buck-boost converter so that it can operate in a wide range of output voltage. Here we will compare the new transformerless buck-boost converter with traditional buck-boost converter and KY buck-boost converter for their performance.

II. WORKING

A. Traditional Buck-Boost Converter

Traditional buck boost converter is the simplest buck-boost converter. Working of traditional buck-boost converter is shown in the Fig.1. When switch S is ON, inductor gets charged and the diode is reverse biased. When switch S is OFF, the energy stored in the inductor is transferred to the output. No energy is transferred by the input during this interval.

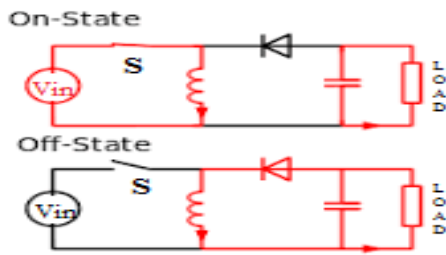

Fig. 1. Working of Traditional Buck-Boost Converter

B. KY Buck-Boost Converter

A typical buck-boost converter, which combines two converters using the same power switches is shown in Fig. 2. One is the SR buck converter, which is built up by two power switches S_1 and S_2 , one inductor L_1 , one energy-transferring capacitor C_1 , whereas the other is the KY converter, which is constructed by two power switches S_1 and S_2 , one power diode D_1 which is disconnected from the input voltage source and connected to the output of the SR buck converter, one energy-transferring capacitor C_2 , one output inductor L_2 , and one output capacitor C_o . The output load is signified by R_o . Furthermore, during the magnetization period, the input voltage of the KY converter is supplied by the input voltage source, whereas during the demagnetization period, the input voltage of the KY converter is supplied from output voltage of the SR buck converter. In addition, during the startup period with S_1 ON and S_2 OFF, the inductors L_1 and L_2 are both magnetized. At the same time, C_1 is charged, and so, the voltage across C_1 is positive, whereas C_2 is reverse charged, and hence, the voltage across C_2 is negative. Sequentially, during the startup period with S_1 OFF and S_2 ON, inductors L_1 and L_2 are both demagnetized. At the same time, C_1 is discharged. Since C_2 is connected in parallel with C_1 , C_2 is reverse charged with the voltage across C_2 being from negative to positive, and finally, the voltage across C_2 is the same as the voltage across C_1 .

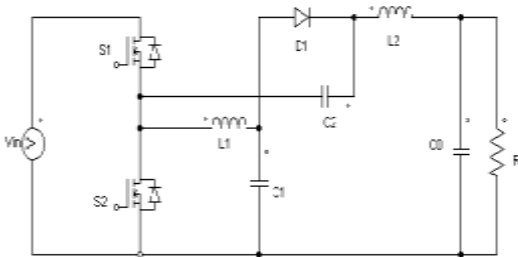

Fig. 2. Circuit Diagram of KY Buck-Boost Converter

C. New Transformerless Buck-Boost Converter

New Transformerless Buck-Boost Converter consists of two power switches (S_1 and S_2), two diodes (D_1 and D_0), two

inductors (L_1 and L_2), two capacitors (C_1 and C_0) and one resistive load (R) is shown in Fig. 3. Power switches S_1 and S_2 are controlled synchronously. When the power switches S_1 and S_2 are turned ON, the diodes D_1 and D_0 do not conduct. At this instant both the inductors L_1 and L_2 are magnetized, and the charge pump capacitor C_1 and the output capacitor C_0 are discharged. When the power switches S_1 and S_2 are turned OFF, the diodes D_1 and D_0 conduct for its and hence both the inductors L_1 and L_2 are demagnetized, and both the capacitors C_1 and C_0 are charged. Here we assumed that the converter operates in steady state, all components are ideal, and all capacitors are large enough to keep the voltage across them constant.

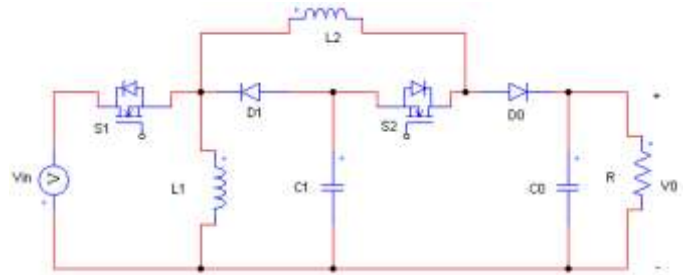

Fig. 3. Circuit Diagram of New Transformerless Buck-Boost Converter

In Continuous Conduction Mode (CCM), there are two modes of operation, that is, mode 1 and mode 2, in the new transformerless buck-boost converter.

a) Mode 1: $NT < t < (N+D)T$

In this mode, the switches S_1 and S_2 are turned on, while D_1 and D_0 are reverse biased. It is seen that L_1 is magnetized from the input supply V_{in} while L_2 is magnetized from V_{in} and capacitor C_1 . This is shown in Fig.4. This time, the output is supplied by the output capacitor C_0 . Thus, the corresponding equations can be established as:

$$V_{L1} = V_{in} \tag{1}$$

$$V_{L2} = V_{in} + V_{C1} \tag{2}$$

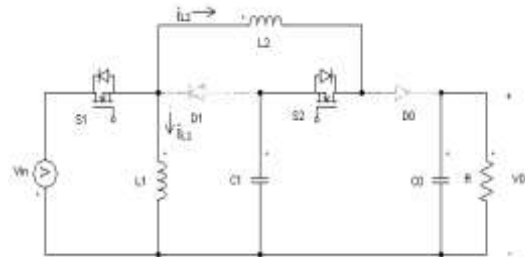

Fig. 4. Circuit of the New Transformerless Buck-Boost Converter in Mode 1

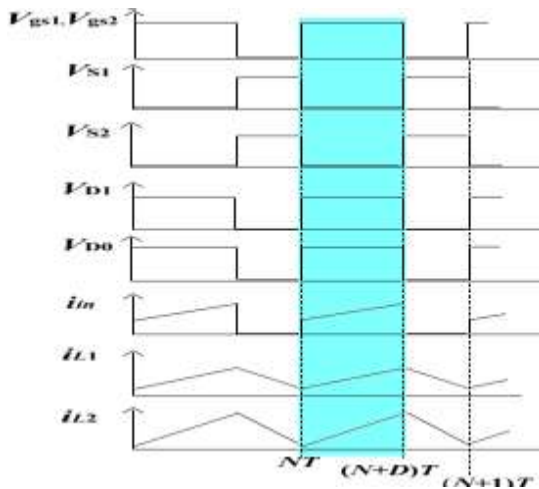

Fig. 5. Theoretical waveforms of the converter in Mode 1 operation

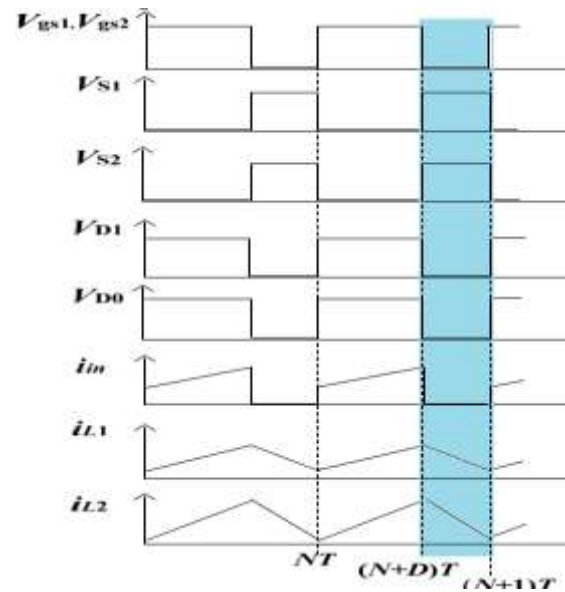

Fig. 6. Theoretical waveforms of the converter in Mode 2 operation

b) Mode 2: $(N+D)T < t < (N+1)T$

In mode 2, the switches S_1 and S_2 are turned off, while D_1 and D_0 are forward biased. It is seen that the energy stored in the inductor L_1 is released to the capacitor C_1 via the diode D_1 . At the same time, the energy stored in the inductor L_2 is released to the capacitor C_1 , the output capacitor C_0 and the resistive load R through the diodes D_0 and D_1 . The equations of the mode 2 are described as follows:

$$V_{L1} = -V_{C1} \quad (3)$$

$$V_{L2} = -(V_{C1} + V_0) \quad (4)$$

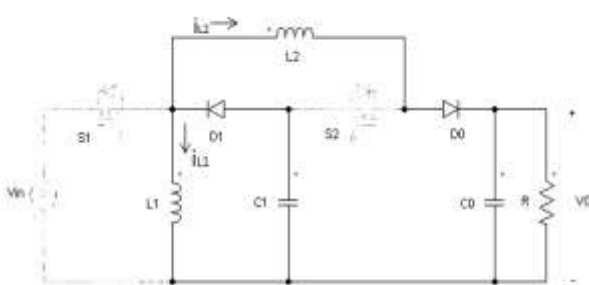

Fig. 6. Circuit of the New Transformerless buck-boost converter in Mode 2

III. SIMULATION MODEL AND RESULTS

A. Traditional Buck-Boost Converter

Traditional Buck-Boost converter is simulated in MATLAB/SIMULINK is shown in the Fig. 7.

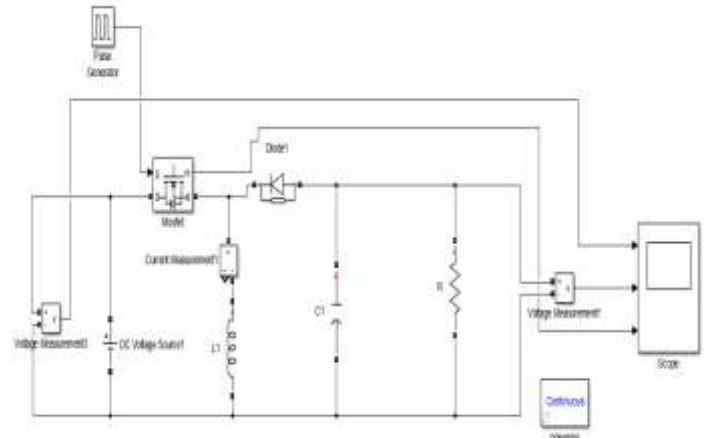

Fig. 7. Simulink model of Traditional Buck-Boost converter

This converter can step-up the input voltage when the duty ratio is bigger than 0.5, and step-down the input voltage when the duty ratio is smaller than 0.5.

The simulation results for a duty ratio of 0.6 (ie, Step Up mode) is shown in the following Fig. 8.

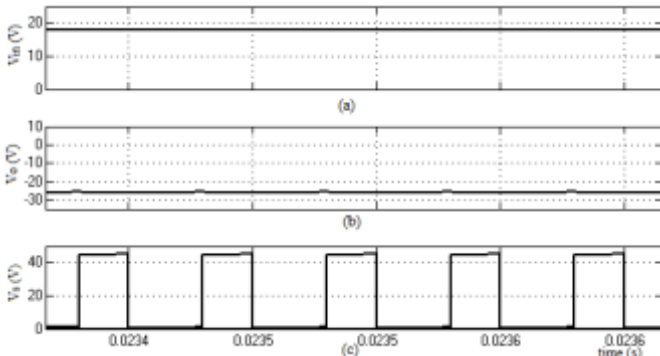

Fig. 8. Simulink result (a) Input Voltage(V_{in}), (b) Output Voltage(V_o) and (c) Switching Stress

When an input voltage of 18V is applied with a duty ratio of 0.6, it produced an output voltage of -26V with a switching stress of 45V.

The simulation results for a duty ratio of 0.4 (ie, Step down mode) is shown in the Fig. 9.

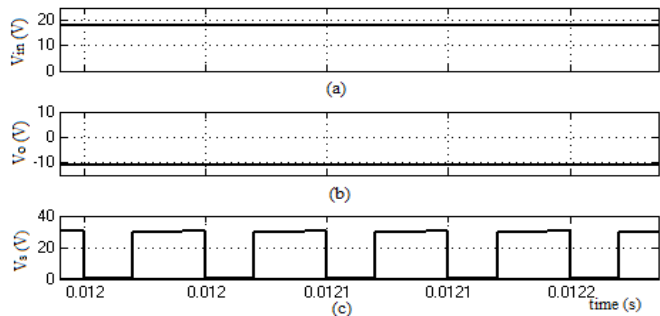

Fig. 9. Simulink result (a) Input Voltage(V_{in}), (b) Output Voltage(V_o) and (c) Switching Stress(V_s)

When an input voltage of 18V is applied with a duty ratio of 0.4, the traditional buck-boost converter produced an output voltage of -11V with a switching stress of 30V.

B. KY Buck-Boost Converter

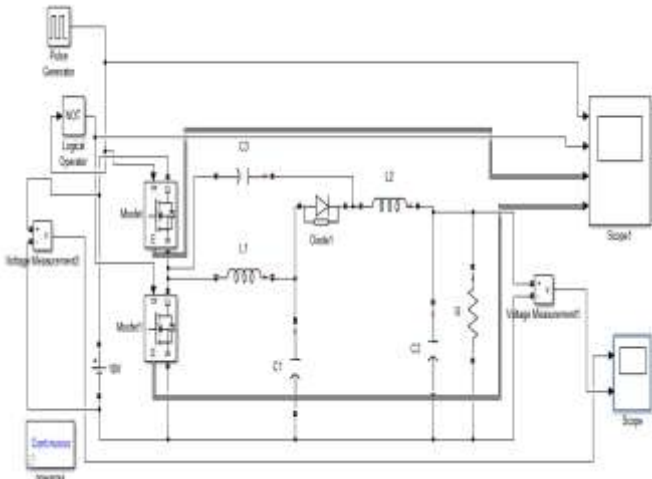

Fig. 10. Simulink model of KY Buck-Boost converter

KY Buck-Boost converter is simulated in MATLAB/SIMULINK is shown in the Fig. 10.

The simulation results for a duty ratio of 0.6 (ie, Step Up mode) is shown in the following Fig.11 and Fig.12.

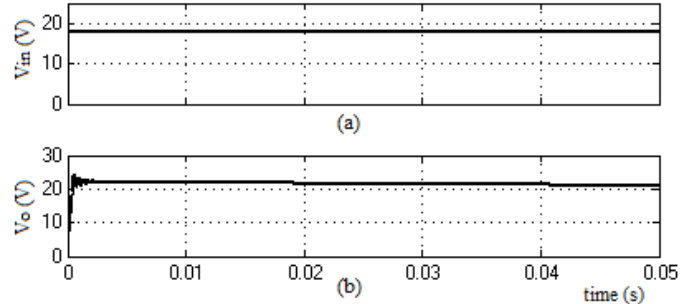

Fig. 11. Simulink result (a) Input Voltage(V_{in}) and (b) Output Voltage(V_o)

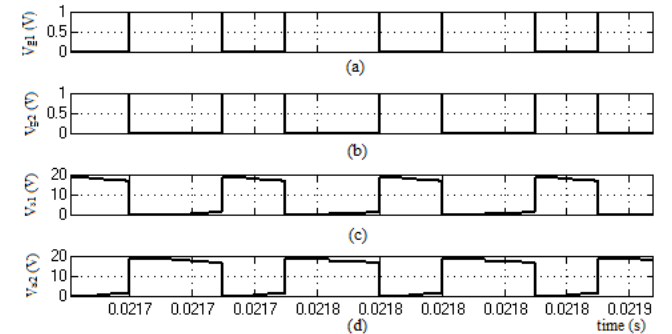

Fig. 12. Simulink result (a) Gate Pulse for S_1 , (b) Gate Pulse for S_2 , (c) Switch1 Stress and (d) Switch2 Stress

The simulation results for a duty ratio of 0.4 (ie, Step down mode) is shown in the following Fig.13 and Fig.14.

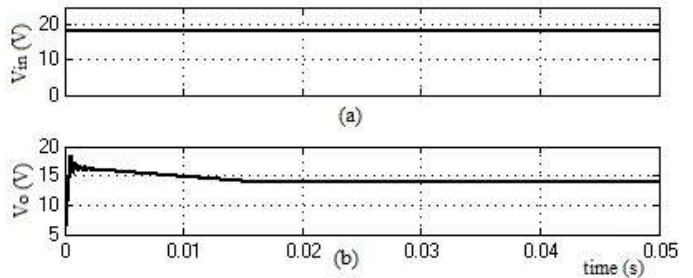

Fig. 13. Simulink result (a) Input Voltage(V_{in}) and (b) Output Voltage(V_o)

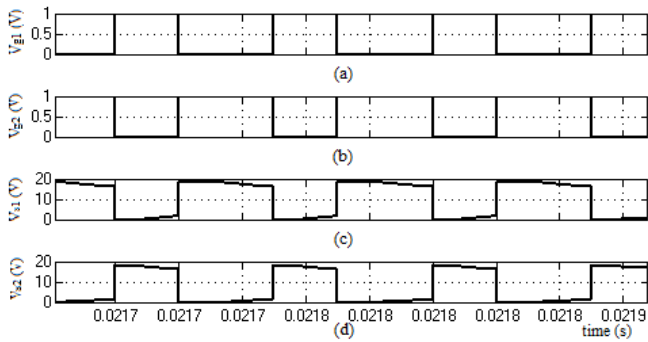

Fig. 14. Simulink result (a) Gate Pulse for S_1 , (b) Gate Pulse for S_2 , (c) Switch1 Stress and (d) Switch2 Stress

From the simulation result it can be inferred that the voltage gain of KY buckboost converter is less than the traditional buck boost converter but has the advantage that the switching stress of this converter is very less and is independent of duty cycle.

C. New Transformerless Buck-Boost Converter

The New Transformerless Buck-Boost converter of Fig. 3 is simulated in MATLAB/SIMULINK by choosing the parameters listed in Table 1 and simulink model is shown in the Fig. 15.

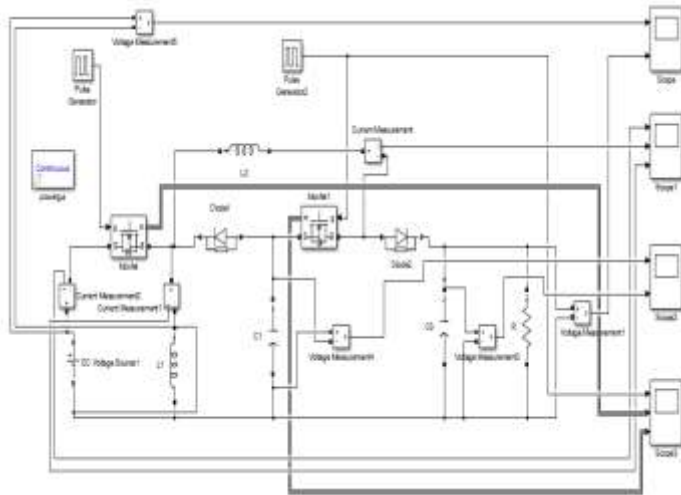

Fig. 15. Simulink model of New Transformerless Buck-Boost converter

Table 1: Simulation Parameters

Input Voltage, V_{in}	18 V
Inductor, L_1	1 mH
L_2	3 mH
Capacitor, C_0	10 μ F
C_1	20 μ F
Resistor, R	100 Ω
Duty Ratio, D	0.4-0.6
Switching frequency, f_s	20 kHz

The simulation results for a duty ratio of 0.6 (ie, Step Up mode) is shown in the following Fig. 16, Fig. 17 and Fig. 18.

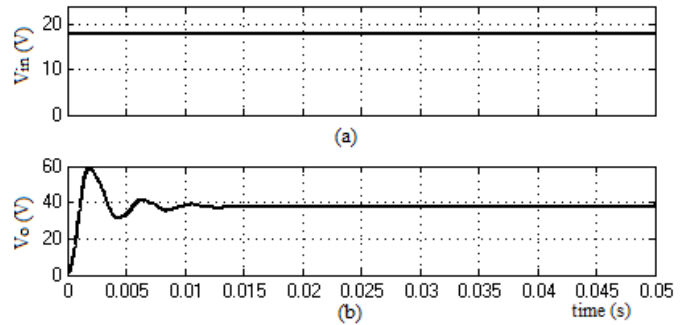

Fig. 16. Simulink result (a) Input Voltage(V_{in}) and (b) Output Voltage(V_o)

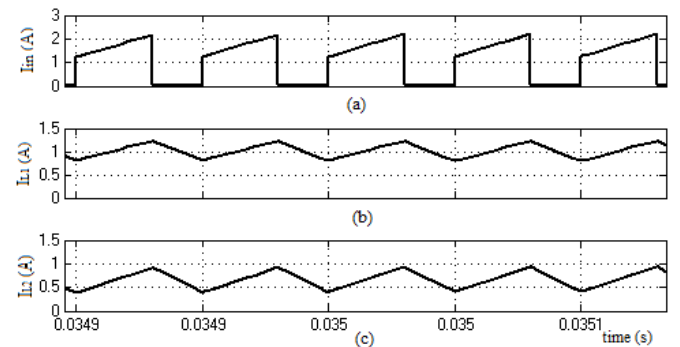

Fig. 17. Simulink result (a) Input Current, (b) Inductor L_2 Current and (c) Inductor L_1 Current

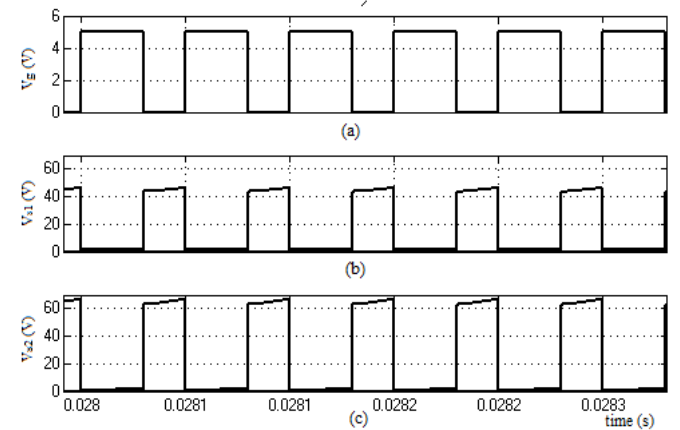

Fig. 18. Simulink result (a) Gate Pulse, (b) Switch1 Stress and (c) Switch2 Stress

It is observed that the charge pump capacitor voltage V_{C1} is within (25.8V, 27.8V), the output voltage V_o is within (39.6V, 40.3V), the inductor current i_{L1} is within (0.7A, 1.21A), and the inductor current i_{L2} is within (0.4A, 0.80A). Also, the ripples of the inductor current Δi_{L1} and the inductor current Δi_{L2} are 0.54A and 0.45A, respectively. It is also observed that a duty ratio of up to 0.6 is suitable for this converter owing to the voltage stress across the switches.



The simulation results for a duty ratio of 0.4 (ie, Step down mode) is shown in the Fig.19, Fig.20 and Fig.21.

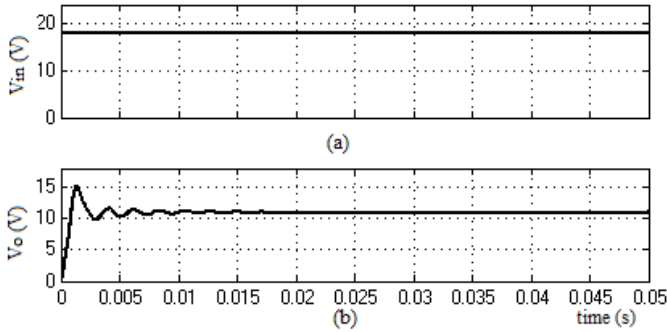

Fig. 19. Simulink result (a) Input Voltage(V_{in}) and (b)Output Voltage(V_o)

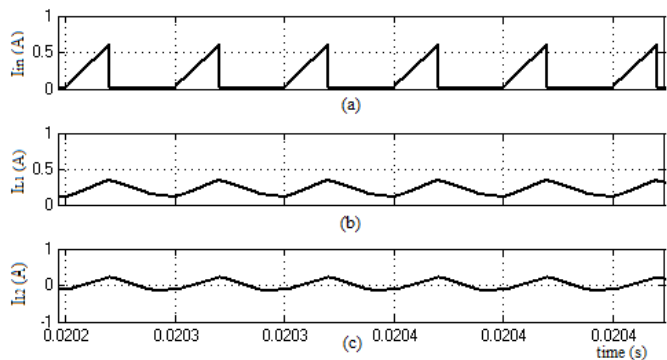

Fig. 20. Simulink result (a) Input Current, (b) Inductor L_2 Current and (c) Inductor L_1 Current

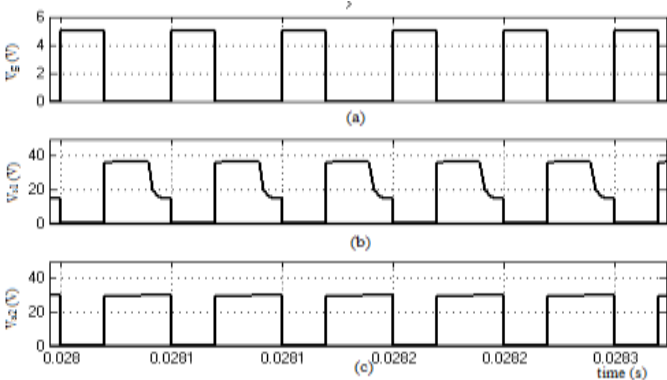

Fig. 21. Simulink result (a) Gate Pulse, (b) Switch1 Stress and (c)Switch2 Stress

It is clearly seen that the charge pump capacitor voltage V_{C1} , the output voltage V_o , the inductor current i_{L1} , and the inductor current i_{L2} are within (17.3V, 17.8V), (11.0V, 11.5V), (-0.2A, 0.4A) and (0.2A, 0.5A) respectively. Also, the ripples of the inductor current Δi_{L1} and the inductor current Δi_{L2} are 0.38A and 0.3A respectively. The ripples of the two capacitors ΔV_{C1} and ΔV_{C0} are 0.89V and 0.29V respectively. The output ripple is also 0.29V.

IV. COMPARISON

A. Voltage Stress

The voltage stress of the power switches are observed from the simulation results and certain inferences are made. A plot of voltage stress across switches for different duty ratios is shown in the Fig. 22. The voltage stress of the power switch S_1 and the diode D_1 are both equal to the voltage stress on the power switch in traditional buck boost converter with same input voltage. Similarly, the voltage stress of the power switch S_2 and the diode D_0 are the same as the voltage stress on the diode in the traditional buck-boost converter. The voltage stresses on the power switches in KY buck-boost converter are very less and same as the input voltage.

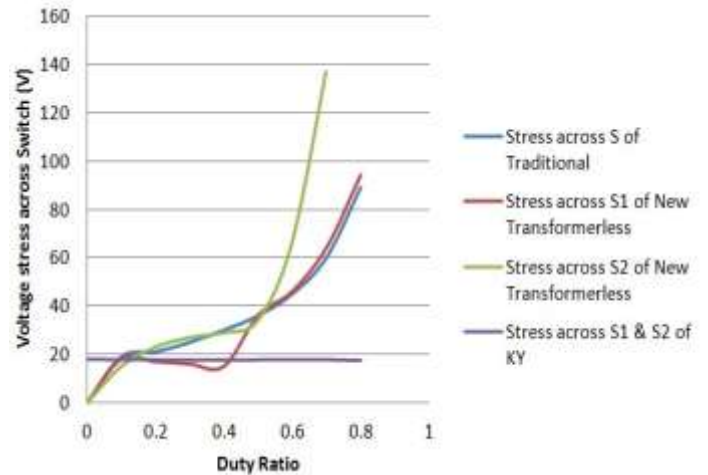

Fig. 22. Comparison about switching stress for different duty ratios

B. Voltage Gain

Voltage Gain of Traditional buck-boost converter is given by

$$M = \frac{V_o}{V_{in}} = \frac{D}{(1-D)} \quad (5)$$

Voltage Gain of KY buck-boost converter is given by

$$M = \frac{V_o}{V_{in}} = 2D \quad (6)$$

Voltage Gain of New Transformerless buck-boost converter is given by

$$M = \frac{V_o}{V_{in}} = \frac{D^2}{(1-D)^2} \quad (7)$$

From the theoretical formulas it is obvious that the New Transformerless buck-boost converter has the better gain among the three. This was further confirmed by the simulation results. The New Transformerless buck-boost converter produced output voltages in wide range without applying extreme duty cycles. Fig. 23 shows the variation in output voltage with change in duty ratios.

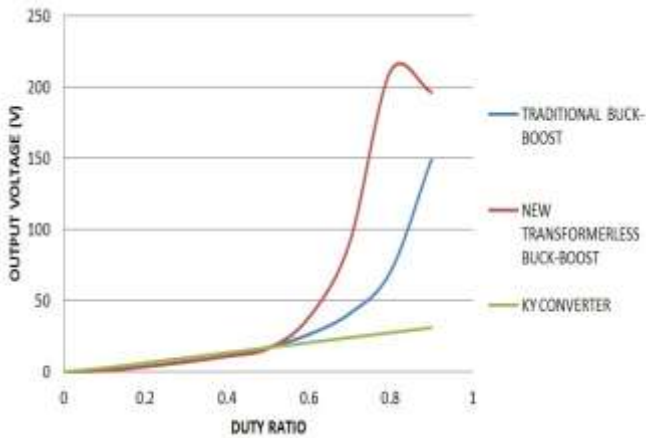

Fig. 23. Variation in output voltage for different duty ratios

C. Complexity And Efficiency

Compared with the traditional buck-boost converter, which has only one power switch, the KY buck-boost converter and New Transformerless, buck-boost converter uses two power switches. Hence the complexity of control is more in the latter two. Traditional buck-boost converter houses minimum number of components compared to the other two. KY buck-boost converter and New Transformerless buck-boost uses two inductors whereas the traditional buck-boost uses only one. KY buck-boost converter has three capacitors, New Transformerless buck-boost has two and traditional buck-boost has only one. Owing to more number of components, the KY buck-boost converter and New Transformerless buck-boost converter are prone to more losses. Hence the efficiency is less for these converters.

The above comparison can be tabulated for easy understanding and is given in Table 2.

Table 2: Comparison between different converters

Topology	Traditional buck-boost converter	KY buck-boost converter	New Transformerless buck-boost converter
Switches	1	2	2
Diodes	1	1	2
Inductors	1	2	2
Capacitors	1	3	2
Voltage Gain (V_o/V_i)	$D/(1-D)$	$2D$	$D^2/(1-D)^2$
Voltage Stress of Switches (V_s/V_i)	$1/(1-D)$	S ₁	1
		S ₂	1
Voltage Stress of Diodes (V_D/V_i)	$1/(1-D)$	1	
		D ₁	$1/(1-D)$
		D ₀	$D/(1-D)^2$
Complexity of small-signal models	Second-order (it has 2 storage elements)	Fifth-order (it has 5 storage elements)	Fourth-order (it has 4 storage elements)

V. EXPERIMENTAL SETUP AND RESULTS

The hardware model of new transformerless buck-boost converter, which is better among the three, is made. In this

experiment, the power switches S_1 and S_2 are realized by the power MOSFET IRFP264, the diodes D_1 and D_0 by MUR810, the other circuit parameters are chosen as the same with the MATLAB simulations.



Fig. 25. Experimental setup for new transformerless buck-boost converter

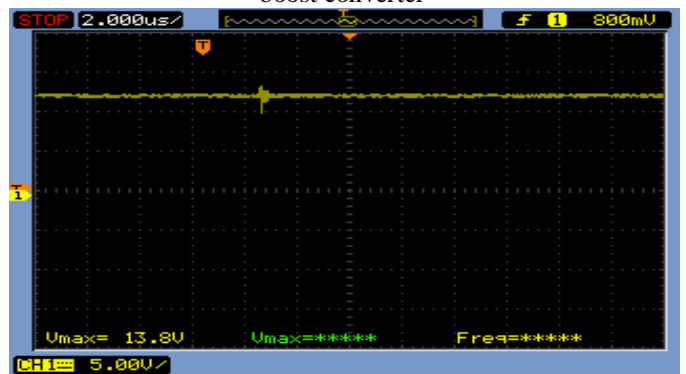

Fig. 26. Output voltage in step-up mode



Fig. 27. Output voltage in step-down mode

In the step-up mode, for an input voltage of 7V and when a duty ratio of 0.6 is applied an output voltage of 13.8V is obtained. This is shown in the Fig. 26. Here a voltage gain of 1.97 is observed. In the step-down mode, for an input voltage of 4V and when a duty ratio of 0.4 is applied an output voltage of 2.08V is obtained. The output voltage in this case is shown in Fig. 27. High input could not be applied because of the problem of inductor saturation. Also the output voltages in



both the modes couldn't meet the expectations owing to the losses.

V. CONCLUSION

A new transformerless buck-boost converter, as a fourth-order circuit, realizes the optimization between the topology construction and the voltage gain to overcome the drawbacks of the traditional buck-boost converter and KY buck-boost converter. The main merit of the new transformerless buck boost converter is that its voltage gain is quadratic of the traditional buck-boost converter so that it can operate in a wide range of output voltages, i.e., this buck-boost converter can achieve high or low voltage gain without extreme duty cycle (0.4-0.6). The simulation results show a power output of 14W for a duty ratio of 0.6. The hardware model of the new transformerless buck-boost converter is made and the simulation results match the hardware results with some error. The hardware model shows a voltage gain of 1.97 in step-up mode for a duty ratio of 0.6. Moreover, the output voltage of this new transformerless buck-boost converter is common ground with the input voltage, and its polarity is positive.

VI. REFERENCE

- [1] Shan Miao, Faqiang Wang and Xikui Ma, "A New Transformerless BuckBoost Converter With Positive Output Voltage", *IEEE Transaction on Industrial Electronics*, vol. 63, Issue: 5, pp. 2965 - 2975, May 2016.
- [2] K. I. Hwu and T. J. Peng, "A novel buckboost converter combining KY and buck converters", *IEEE Transactions on Power Electronics*, vol. 27, no. 5, pp. 2236-2241, May 2012.
- [3] Maksimovic and S. Cuk, "Switching converters with wide DC conversion range", *IEEE Transactions on Power Electronics*, vol. 6, no. 1, pp.151-157, January 1991.
- [4] Ajami, H. Ardi and A. Farakhor, "Design, analysis and implementation of a buckboost DC/DC converter", *IEEE Transactions on Power Electronics*, vol. 7, no. 12, pp. 2902-2913, December 2014.
- [5] K. I. Hwu and Y. T. Yau, Two Types of KY BuckBoost Converters, *IEEE Transaction on Industrial Electronics*, vol. 56, no.8, pp. 2970-2980, August, 2009.
- [6] L. S. Yang, T. J. Liang and J. F. Chen, "Transformerless DC-DC converters with high step-up voltage gain", *IEEE Transactions on Industrial Electronics*, vol. 56, no. 8, pp. 3144-3152, August 2009.
- [7] T. F. Wu and Y. K. Chen, "Modelling PWM DC-DC converters out of basic converter units", *IEEE Transactions on Power Electronics*, vol. 13, no. 5, pp. 870-881, September 1998.

- [8] K. I. Hwu, and Y. T. Yau, "KY Converter and Its Derivatives", *IEEE Transaction on Power Electronics*, vol. 24, no.1, pp. 128-137, January 2012
- [9] W. H. Li, and X. N. He, "Review of non-isolated high step up DC-DC converters in photovoltaic grid-connected applications", *IEEE Transactions on Industrial Electronics*, vol. 58, no. 4, pp. 1239-1250, April 2011.
- [10] C. T. Pan, and C. M. Lai,, "A high-efficiency high step-up converter with low switch voltage stress for Fuel-cell system applications", *IEEE Transactions on Industrial Electronics*, vol. 57, no. 6, pp. 1998-2006, June 2010.

IJEAST

INTERNATIONAL JOURNAL
OF ENGINEERING APPLIED SCIENCE
AND TECHNOLOGY

ABOUT IJEAST

International Journal of Engineering Applied Science and Technology (IJEAST) is a peer-reviewed, open access journal that publishes high-quality research papers in the field of Engineering, Applied Science and Technology.

IJEAST aims to provide a platform for researchers, academicians, and professionals to share their innovative ideas, research findings, and practical experiences with the global scientific community.

FOCUS AREAS

- Engineering
- Applied Science
- Technology
- Innovation & Development
- Interdisciplinary Studies



PEER REVIEWED

All submissions are rigorously peer reviewed to ensure quality.



OPEN ACCESS

Free and unrestricted access to research for all.



GLOBAL REACH

Connecting researchers and professionals worldwide.



TIMELY PUBLICATION

We ensure a swift and efficient publication process.



For more information, visit our website

www.ijeast.com



INTERNATIONAL JOURNAL
OF ENGINEERING APPLIED SCIENCE
AND TECHNOLOGY

✉ editor@ijeast.com

🌐 www.ijeast.com

📍 India



2455-2143