



# IJEAST

INTERNATIONAL JOURNAL  
OF ENGINEERING APPLIED SCIENCE  
AND TECHNOLOGY



**VOLUME : 4    ISSUE : 06    Print / Issue Publication Date: 06-Dec-2019**



**ISSN : 2455-2143**



**DOI : 10.33564/IJEAST.2019.v04i06.003**

Indexed In



[WWW.IJEAST.COM](http://WWW.IJEAST.COM)

[editor@ijeast.com](mailto:editor@ijeast.com)



# PERFORMANCE AND FEASIBILITY STUDY OF A ROOFTOP PV SYSTEM ON A TYPICAL COMMERCIAL BUILDING SPACE

Ahnaf Tahmid Nahian, Md.Tahmid Farhan Himel, Kaiser Habib  
Institute of Energy, University of Dhaka, Bangladesh

Minhazur Rahman, Sharmin Khatun  
Department of EEE,  
American International University-Bangladesh

**Abstract**— In the present scenario, the rapid increase of fuel cost and utility price in Bangladesh is providing hindrance for the growth of its economy. Energy demand is very sensitive for the activities of day to day life. However, the vast availability of rooftop makes our living and working place a lucrative candidate for solar photovoltaic adoption. This research identifies various aspects of solar photovoltaic adoption in commercial spaces where important decision regarding the development of economy take place by considering economic and technical viability through this feasibility study. This technical study suggest that the implementation of solar photovoltaic will remedy the suffering of working people during the time of load shedding. The aim of this paper is to achieve the optimal export rate in different conditions such as incentives, grants, and interest rate. Proper incentives and reduction of bank interest can make the renewable energy electricity generation adoption in commercial building space competitive with traditional power generation. The proposed project life is about 20 years and the payback period is only 7.9 years with positive NPV and higher IRR.

**Keywords**— Solar PV, Electricity, Net metering, NPV, IRR, Payback period

## I. INTRODUCTION

The most apposite one between many forms of energy, electricity is the dynamic force after all types of human activities, developments and researches in other areas of technologies. Briefly, it is the electricity that gives birth to other technologies. In a typical developing country each 1% growth of GDP leads to a rise of 1.4% demand of electricity. Extra electricity consumption is prerequisite to make higher growth in GDP. [1] In 2017, worldwide total electricity generation was 25551.3 TWh out of which 883 TWh was generated from oil, 5915.3 TWh was generated from natural gas, 9723.4 TWh was generated from coal, 2635.6 TWh was generated from nuclear energy, 4059.9 TWh was generated from hydroelectricity and 2151.5 TWh was generated from

renewable energy. [2] According to Bangladesh Power development Board, the installed power generation capacity is about 18454 MW, derated power generation capacity is 17911 MW out of which 444 MW is generated by coal fired power plants, 9406 MW is generated by gas with 39.97% plant efficiency, 4490 MW is generated by HFO with 39.89% plant efficiency, 2181 MW is generated by HSD with 31.69% of plant efficiency, 230 MW is generated by hydro, and 1160 MW is imported. [3, 4] However of this, Bangladesh quiet strives from foremost scarcity of electricity generation to achieve the daily demand and the peak demand would be approximately 17,304 MW in FY2020 and 25,199 MW in 2025 [5]. According to SREDA, renewable energy adds only 3.06% in entire energy mix in the year of 2018. [6] In Bangladesh Solar, biomass & wind are the extended contestant amongst the reachable renewable energy resources. Hypothetically, Bangladesh gets 69,751 TWh energy each year which is 3000 times higher than the conventional electricity generation [7]. In Bangladesh each year, solar radiation has an usual power density of 100-300 W/m<sup>2</sup> which can produce 100 MW electricity with an area of 3-10 km<sup>2</sup> with a panel of 10% efficiency [8]. In a year with 6.8% (10,000 km<sup>2</sup>) of the land of Bangladesh, per capita 3000 kWh electricity mandate can be achieved [9]. The government of Bangladesh acmes the prerequisite of installing rooftop solar PV system due to the shortage of land. It has been found that 1000 MW of solar PV electricity with 75 W capacity of the solar module can be produced by the total reachable sunny rooftops area in Dhaka city which is 10.554 km<sup>2</sup>. [10] In Bangladesh only 1.7% appropriate land area is used for producing electricity from solar PV as the nearby existence of grid connection [11]. It is found that solar PV operated in a grid-connected mode with 10% efficiency of solar PV system and 200 W/m<sup>2</sup> yearly usual value of solar radiation can produce near 50,174 MW of grid electricity in Bangladesh. [12]

## II. METHODOLOGY

The location of the project is a commercial space namely, Lanka Bangla Finance Ltd. Which is situated in Faridpur, Bangladesh. The Geological coordinates of the area is 23.598<sup>0</sup> N (latitude) and 89.8306<sup>0</sup> E (longitude). The area is a two storied commercial building with a rooftop of approximately 2300 sq. feet, with an available area of 1200 aq. Feet in south. The objective of this research is to establish a rooftop PV system on top of the building so that it can supply electricity alongside with the grid to the connected loads in times of black out. To serve this purpose the copy of billing for different months of 2018 and 2019 are collected. The site considered for this project, is a part of urban areas with an existence of grid electricity though the supply is not continuous resulting a number of load shading. Analysis of load profile and load factor was done to proper sizing of PV system. After that, the feasibility analysis and optimization of the system has been done via RET Screen software.

## III. ROOFTOP PV DESIGN ANALYSIS

Rooftop PV system commonly refers to the photovoltaic system having electricity-generation units mounted on the rooftop of a residential or commercial building or structure. The system is more compact compared to ground mounted photovoltaic power stations. The capacity of the system could sometime rise up to megawatt range. Various impacts including seasonal variation, time, latitude, roof slope, roof aspect, shading analysis and vegetation affects the installation process and output of the system.

### A. Load Profile

The building is mainly an office area having diversified load. Depending on the nature of work, miscellaneous loads are operated. The system was designed in such a way that it can cover maximum load of the area. Load profile of the system is shown in Table 1.

The annual electricity consumption of the system are given below as tabular form. It should be noted that entire electricity of the system are supplied by grid utility of local area. Electricity consumption of Load for the year 2019 (Up to June) is shown in Table 2.

Electricity consumption of load for the year of 2018 are presented below as a tabular form in Table 3

### B. Load Factor

Load factor is a crucial part for every existing power system. Demand of energy can be diminished by improving the load factor of the system. By increasing the value of load factor average unit cost (both demand and energy) of the kWh can be deduced. Improving the value of load factor can lead to the substantial savings. High load factor indicates an efficient system. The value of load factor can be calculated as the ratio of actual energy consumption (kWh) and the maximum power recorded (demand) for that period of time. Thus the equation of the load factor can be determined as

$$\text{Load Factor} = \frac{\text{Total kWh for billing period} * 100}{\text{Maximum Demand} * \text{Number of Days} * 24}$$

Value of load factor can be derived from the load profile. The output is always less than one because the maximum demand is always higher than the average load. High value of load factor implies constant power utilization, where the lower value of load factor implies occasional high demand of power. According to electrical rating system, power system having higher value of load factor are charged less overall per kWh. This is called load balancing mechanism. Load factor for the different months of year 2018 is shown in Table 4. Load factor for the different months of year 2019 is shown in Table 5.



Fig 1 Utility grid bill for the month of April 2019



Fig 2 Utility grid bill for the month of May 2019

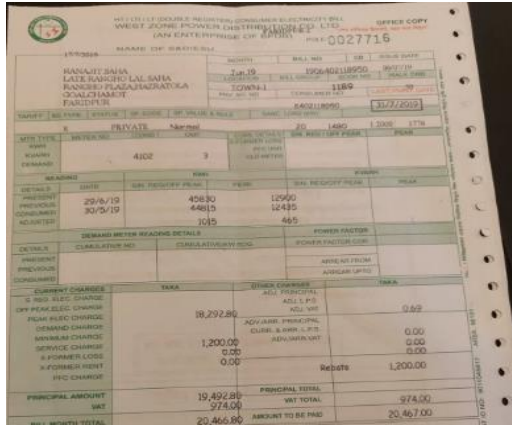

Category	Item	Rate	Quantity	Amount
DEMAND WITH READING DETAILS	PREVIOUS MONTH	40630	10940	12435
	CURRENT MONTH	44815	11890	13710
	ADJUSTMENT	1015	465	465
	TOTAL			13710
CURRENT CHARGES	REGISTRATION FEE	1,200.00		1,200.00
	CONNECTION FEE	0.00		0.00
	MONTHLY CHARGE	0.00		0.00
	POWER FACTOR PENALTY	0.00		0.00
PRINCIPAL TOTAL	PRINCIPAL TOTAL	15,492.85		15,492.85
	AMOUNT TO BE PAID	274.00		274.00
TOTAL	TOTAL	20,466.85		20,466.85

Fig 3 Utility grid bill for the month of June 2019

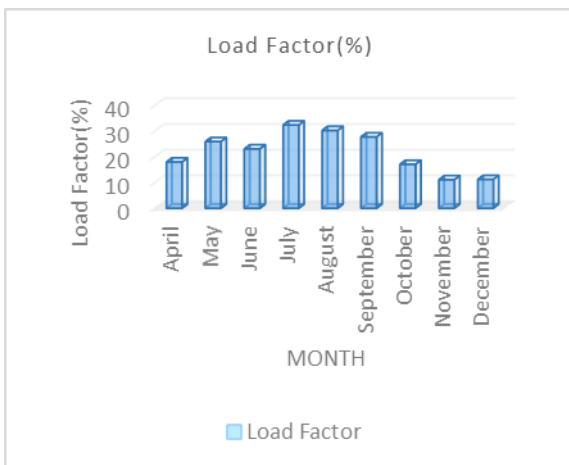

Fig 4 Load factor for the different months of year 2018

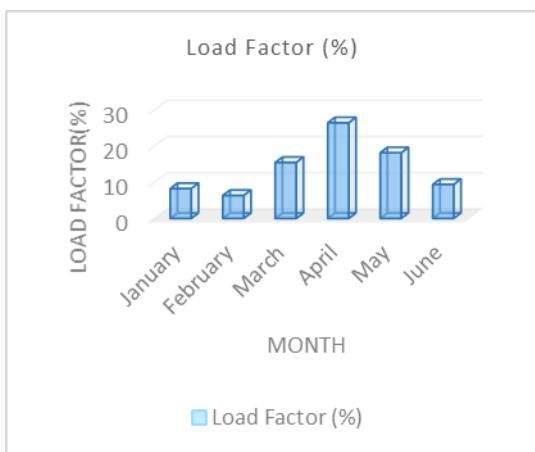

Fig 5 Load factor for the different months of year 2019

### C. Design of a Typical Off grid Rooftop PV system

Design of a rooftop PV system needs considerations on many aspects. System has to be proper sized otherwise there will be unnecessary production of electricity which will cause the system damage and will increase the electricity generation cost.

#### Array sizing:

Due to the size of the rooftop, maximum PV array that could be installed is 10 kWp. The panel capacity is chosen as 250 Wp.

$$\text{No of Panels} = 10000/250 = 40$$

$$\text{No of Array} = 2, (5 \text{ kWp each})$$

$$\text{No of Module in series } N_s = 20$$

$$\text{No of Module in parallel} = 2$$

#### Selection of a Grid-Tied Inverter:

Number of inverters required for the system = 2 (each rated 5kW, 48 v)

#### Battery Sizing:

The battery capacity required at C (Ah) should be calculated using the following formula

$$C (Ah) = \frac{PL (Ah) * Backup time}{DOD * Efficiency of the battery system * Inverter Efficiency}$$

$$\text{Total no. of battery required} = 20 * 1 = 20$$

### D. Design and Analysis of Standalone PV System by Useful Parameters

A small office with a boundary area of 2300 sq. feet has been considered for the project. The two storied building has two working space. The connected load of the space is 15 kW. Depending on the value of utility's consumption this area needs about 250 Wp PV panel. The proposed system is off grid and will act as an independent solar home system. Rooftop of the building is chosen as the area for the system setup. The block diagram of proposed PV system are presented below. In this system two 250 Wp PV array are chosen as the main power source of the system with a panel capacity of 250 Wp. The panels directly lead to the DC distribution box via MPPT charge controller (120A). From their connections are given to the battery bank so that they can store charges that can be used in the time of need. Other connections are directed to the inverters (48 V, 800 VA), so that the dc power produced from the PV can be converted into AC power. From inverter the system connections were given to AC distribution box. Two types of protecting mechanism MCB & MCCB are used in this process. After that the output PV power is lead to the AC plug in port via metering units.

The analysis is mainly done for a typical rooftop PV system wish to be founded on the surface of rooftop. For the design and simulation purpose electricity consumption for the month of May 2019 has chosen as it yield higher load factor and a feasible cost effective load solution. According to the collected billing data, the month (May) yield a very high load factor, this system is also appropriate for the months with lower value of load factor.

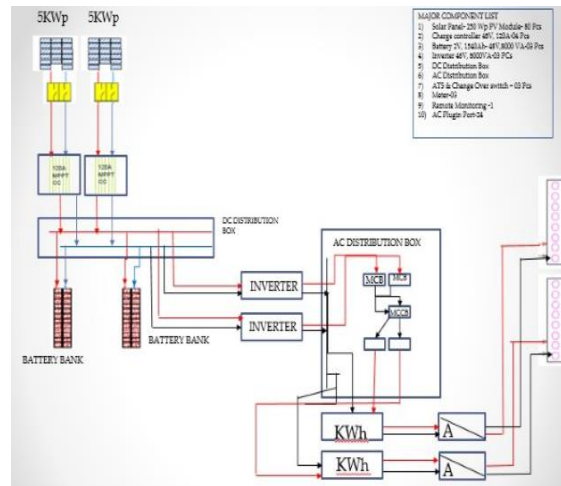

Fig 6 Block diagram of the PV system (off grid)

Table 1 Load profile of the system

Load	Hours of use per day(hr)	Watt rating (W) (Base case Load)	Days of use per week	Load type(AC)
LED	6	150	5	Positive
Photocopy	3.50	1300	5	Positive
Oven	2	2400	5	Positive
Fridge	24	1000	7	Zero
Coffee maker	1.50	800	5	Positive
AC	5	8000	5	Positive
CC camera	24	30	5	Zero
Phone charger	5	100	5	Positive
Printer and scanner	2	50	5	Positive
Laptop	4	500	5	Positive
Table fan	3	10	5	Positive
Phone charger	2	72	5	Positive
<b>Total</b>		<b>Total load=15kW</b>	<b>Total Energy=63.25 kWh</b>	

Table 2 Electricity consumption of Load for the year 2019 (Up to June)

Months	Electricity Consumption(kWh)
January	890
February	685
March	1670
April	2855
May	1960
June	1015

Table 3 Electricity consumption of Load for the year 2018 (April to December)

Months	Electricity Consumption (kWh)
April	1945
May	2800
June	2500
July	3500
August	3270
September	3000
October	1845
November	1200
December	1210

Table 4 Load factor for the different months of year 2018

Months	Load Factor (%)
April	18
May	25.92
June	23.1
July	32.40
August	30.27
September	27.77
October	17.08
November	11.11
December	11.20

Table 5 Load factor for the different months of year 2019

Months	Load factor (%)
January	8.24
February	6.34
March	15.46
April	26.43
May	18.14
June	9.39

#### IV. FEASIBILITY & PERFORMANCE STUDY OF A PV SYSTEM BY RET SCREEN SOFTWARE

According to load profile and considering two days of autonomy and other conditions simulation was run in RET Screen and found that the number of module required to sustain this project was 10kWp with 18000 Ah, 12 V battery. The electricity generation were used as financial indicator of our system. These data are presented below in tabular form. Electricity generation for different solar radiation is shown in Table 6.

##### A. Financial Analysis by RET Screen

To evaluate a project or investment, it is important to calculate the NPV, IRR, Payback period, Year to positive cash flow and PI index for the project. The parameter is very sensitive to PV cost, subsidy, discount rate and energy price rate. Financial viability for off grid and grid tied system is shown in Table 7. Financial parameter for off grid and grid tied system is shown in Table 8. Initial cost (BDT) for off grid system and grid tied system is shown in Table 9. Balance of system & miscellaneous cost (BDT) for off grid system is shown in Table 10. Annual cost & Debt Payment is shown in Table 11.

##### B. Cumulative Cash Flow Graph

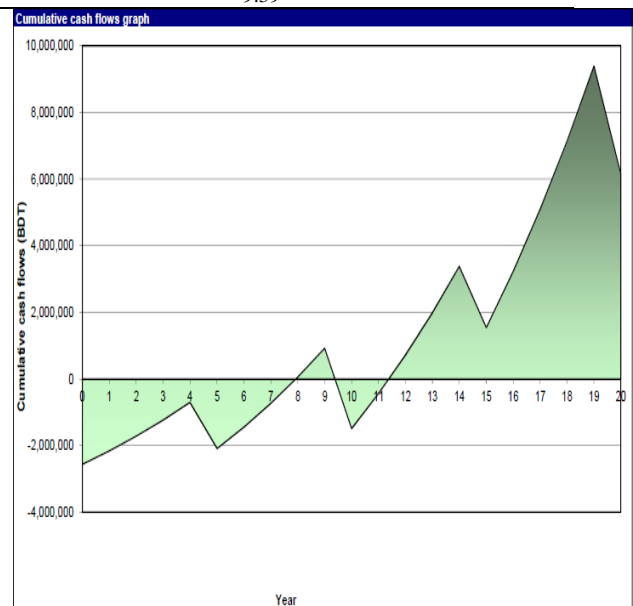

Fig 7 Cumulative cash flow diagram of a 10kW off-grid (battery backup) system

Above figure explains the cash flow of the entire project. According to diagram it takes more than 8 years for the project to reach the break even. Up to eight years cash flow is negative which indicates that the project won't be feasible up to this period. After 19 years the cash flow will reach up to its peak value. Maintenance and components replacement costs will increase the overall system cost which will impact on benefit to cost ration of the project. But considering overall scenario of the project it is found that the project is feasible and implementation of this project will help to offset the consequences of random blackout of this particular zone.

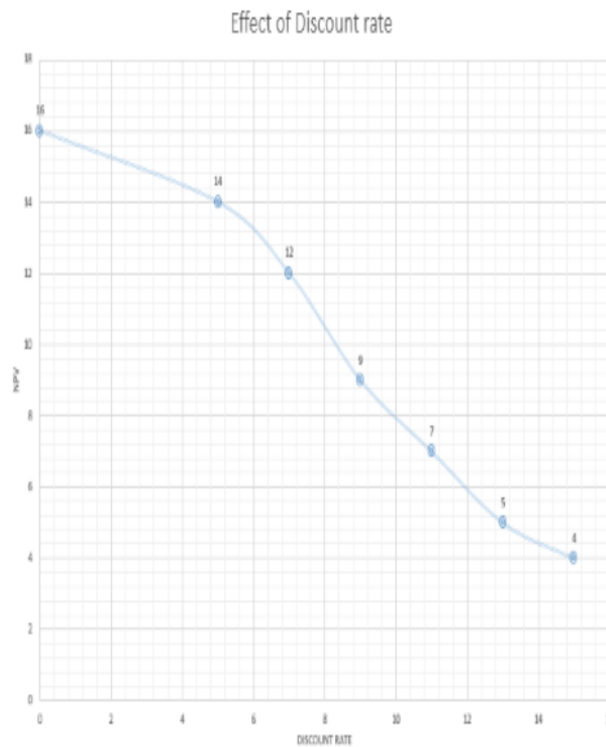

Fig 8 Effect of discount rate

The effect of discount rate on NPV is shown below. The project is feasible but NPV is declining with the increase of discount rate.

Table 6 Electricity generation for different solar radiation

Month	Daily solar radiation- horizontal kWh/m <sup>2</sup> /d	Daily solar radiation- Tilted kWh/m <sup>2</sup> /d	Electricity Delivered to Load MWh
January	4.36	5.56	1.18
February	4.92	5.78	1.07
March	5.59	6.00	1.21
April	5.76	5.69	1.12
May	5.30	4.97	1.02
June	4.53	4.19	0.84
July	4.23	3.96	0.82
August	4.29	4.15	0.85
September	4.02	4.10	0.82
October	4.32	4.82	0.99
November	4.28	5.30	1.06
December	4.21	5.52	1.15
<b>Annual</b>	<b>4.65</b>	<b>5.00</b>	<b>12.09</b>

Table 7 Financial viability for off grid and grid tied system

	Pre-tax IRR- equity (%)	Pre-tax IRR- assets (%)	After- tax IRR- equity (%)	After- tax IRR- assets (%)	Simple Payback (yr)	Equity Payback (yr)	Net present value (NPV) (BDT)	Annual life cycle savings (BDT/yr)	Benefit- cost ratio	GHG Reduction Cost (BDT/tCO <sub>2</sub> )	Energy Production cost (BDT/MWh)
Off-grid	12.6	12.6	12.6	12.6	7.0	7.9	8,66,963	94,973	13.4	14,354	



(battery backup system)											
Grid-tied system With net metering	negative	negative	negative	negative	13.8	>project	-959,398	-105,099	0.07	12,458	12,316.80

Table 8 Financial parameter for off grid and grid tied system

Parameter	Off grid system	Grid tied system
Fuel cost escalation rate (%)	10	10
Inflation rate (%)	5.5	5.5
Discount (%)	9	9
Project life (yr)	20	20

Table 9 Initial cost (BDT) for off grid system and grid tied system

Parameter	Percentage (%)	Initial cost (BDT) for off grid system	Initial cost (BDT) for grid-tied system
Feasibility study	0.4	10,000	10,000
Development	0.4	10,000	10,000
Engineering	0.4	10,000	10,000
Power system	22.1	5,65,000	5,50,000
Balance of system & miscellaneous	76.7	19,62,000	4,50,000
<b>Total</b>	<b>100</b>	<b>25,57,000</b>	<b>10,30,000</b>

Table 10 Balance of system & miscellaneous cost (BDT) for off grid system

Specific project cost	Power Rating	Price (BDT)
Inverter	15 kW	4,50,000
Battery	216 kWh	15,12,000
Subtotal cost		19,62,000
Total cost(including contingencies and interest during construction)		20,07,000

Table 11 Annual cost & Debt Payment

Annual cost & Debt Payment	Price(BDT) for off grid system	Price(BDT) for grid tied system
Operation & Maintenance	10,000	10,000
Fuel cost-proposed Case	1,53,899	0
Total annual cost(BDT)	1,63,899	10,000
Periodic cost(credits)	15,12,000	4,50,000
Fuel cost(base case)	5,26,648	0
Electricity export income(BDT)		84,797
<b>Total annual savings &amp; income(BDT)</b>	<b>5,26,648</b>	<b>84,797</b>

### C. Cumulative Cash Flow Graph



Fig 9 Cumulative cash flow diagram of grid-tied net metering system

Above figure explains about the cumulative cash flow of grid tied net metering system, where the PV generator is supposed to feed only the grid according to the net metering policy. According to diagram it is seen that the project is not be feasible (even after 20 year). NPV of the project is negative and benefit to cost ratio is almost zero which also indicates towards the negative feasibility of the entire project. It's because according to policy of net metering system in Bangladesh electricity export rate is only 5.5 taka which is quite less than the electricity production cost by PV generator as they require annual maintenance and operating cost. Besides the roof area for the installation project is not sufficient for large scale production of electricity. That's why the idea of on grid system with net metering mechanism is not feasible for this project.

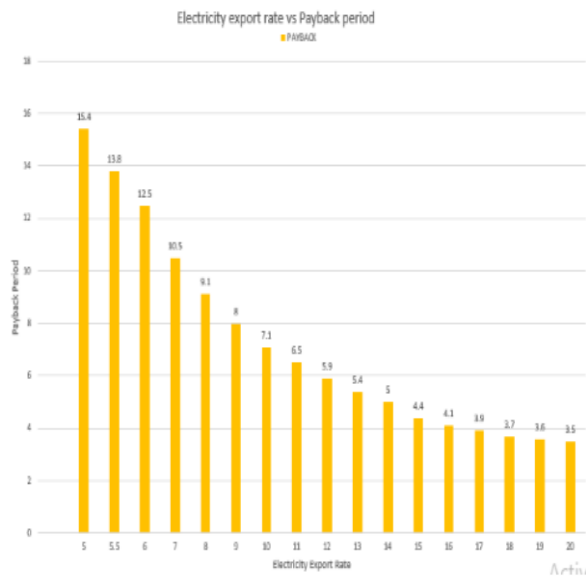

Fig 10 Graphical representation of electricity export rate with payback period

According to the above figure it is seen that by increasing the value of electricity export rate payback period decreases from the system. Higher value of electricity export rate corresponds to lower payback period in case of grid tied net metering system. If the electricity export rate is 20BDT/kWh then the payback period will be low as 3.5 years which is impractical due to current utility grid rate.

### V. CONCLUSION

Access of electricity has a sustainable impact on economic development, growth of productivity and local employment. To raise an economy into an upward spiral of continuous prosperity, some basic criterion must be afforded. Providing sufficient electricity from a reliable power source is one of the prerequisite for an important catalyst for sustainable development. The goal of this research was to perform a feasible study on setting an off grid rooftop PV system on the roof space of a commercial building. To design this optimal power solution, a detail study was done about the location, resource evaluation and load analysis on apparel division of the particular space (Lanka Bangla Finance Ltd, Faridpur Branch). After considering the load requirements a system based on renewable resources to power the load with an assurance of quality, warranty, cost of servicing, spare parts availability and maintenance to ensure uninterrupted supply of electricity was proposed.

### VI. REFERENCES

- [1] Asit Mohanty & Devtosh Chaturvedi. Relationship between Electricity Energy Consumption and GDP: Evidence from India. International Journal of Economics and Finance; Vol. 7, No. 2; 2015. doi:10.5539/ijef.v7n2p186
- [2] BP Statistical Review of World Energy, June-2018
- [3] Bangladesh power Development Board [http://www.bpdb.gov.bd/bpdb\\_new/index.php/site/owner\\_wise\\_daily\\_generation\\_2019](http://www.bpdb.gov.bd/bpdb_new/index.php/site/owner_wise_daily_generation_2019)
- [4] Dr Khondaker Golam Moazzem, Mohammad Ali. The Power and Energy Sector of Bangladesh: Challenges of Moving beyond the Transition Stage. Paper is presented in a national dialogue on "Power and Energy Sector: Immediate Issues and Challenges" organized by the Centre for Policy Dialogue (CPD) held on 10 March, 2019.)
- [5] Md.Tahmid Farhan Himel and Ahnaf Tahmid Nahian, "Integrated Energy Management of Residential Halls at University of Dhaka by Using Energy Efficient Appliances and Solar PV System", International Journal of Engineering and Management Research vol-9, no 1, pp. 87-100 <http://doi.org/10.31033/ijemr.9.1.7>
- [6] Sustainable and Renewable Energy Development Authority ([http://www.sreda.gov.bd/index.php/site/re\\_present\\_status](http://www.sreda.gov.bd/index.php/site/re_present_status)) 2019



- [7] M. S. H. Lipu, M. S. Uddin, and M. A. R. Miah, "A Feasibility Study of Solar-Wind-Diesel Hybrid System in Rural and Remote Areas of Bangladesh," *Int J Renew Energy Res*, vol. 3, no. 4, pp. 892–900,
- [8] B. Van der Zwaan and A. Rabl, "Prospects for PV: a learning curve analysis," *Sol Energy*, vol. 74, no. 1, pp. 19–31, 2003.
- [9] S. Islam and A.-U. Huda, "Technical note Proper utilization of solar energy in Bangladesh: effect on the environment, food supply and the standard of living," *Renew Energy*, vol. 17, no. 2, pp. 255–263, Jun. 1999.
- [10] M. H. Kabir, W. Endlicher, and J. Jägermeyr, "Calculation of bright roof-tops for solar PV applications in Dhaka Megacity, Bangladesh," *Renew Energy*, vol. 35, no. 8, pp. 1760–1764, 2010.
- [11] B. Sørensen, "GIS management of solar resource data," *Sol Energy Mater Sol Cells*, vol. 67, no. 1, pp. 503–509, 2001.
- [12] M. A. H. Mondal and M. Denich, "Assessment of renewable energy resources potential for electricity generation in Bangladesh," *Renew Sustain Energy Rev*, vol. 14, no. 8, pp. 2401–2413, 2010.

# IJEAST

INTERNATIONAL JOURNAL  
OF ENGINEERING APPLIED SCIENCE  
AND TECHNOLOGY

## ABOUT IJEAST

International Journal of Engineering Applied Science and Technology (IJEAST) is a peer-reviewed, open access journal that publishes high-quality research papers in the field of Engineering, Applied Science and Technology.

IJEAST aims to provide a platform for researchers, academicians, and professionals to share their innovative ideas, research findings, and practical experiences with the global scientific community.

## FOCUS AREAS

- Engineering
- Applied Science
- Technology
- Innovation & Development
- Interdisciplinary Studies



### PEER REVIEWED

All submissions are rigorously peer reviewed to ensure quality.



### OPEN ACCESS

Free and unrestricted access to research for all.



### GLOBAL REACH

Connecting researchers and professionals worldwide.



### TIMELY PUBLICATION

We ensure a swift and efficient publication process.



For more information, visit our website  
[www.ijeast.com](http://www.ijeast.com)



INTERNATIONAL JOURNAL  
OF ENGINEERING APPLIED SCIENCE  
AND TECHNOLOGY

✉ [editor@ijeast.com](mailto:editor@ijeast.com)

🌐 [www.ijeast.com](http://www.ijeast.com)

📍 India



2455-2143