



IJEAST

INTERNATIONAL JOURNAL
OF ENGINEERING APPLIED SCIENCE
AND TECHNOLOGY



VOLUME : 7 ISSUE : 03 Print / Issue Publication Date: 29-Aug-2022



ISSN : 2455-2143



DOI : 10.33564/IJEAST.2022.v07i03.022

Indexed In



WWW.IJEAST.COM

editor@ijeast.com



THE IMPACT OF ORGANIZATIONAL CITIZENSHIP BEHAVIOUR AMONG WORKING WOMEN EMPLOYEES AT INFORMATION TECHNOLOGY PROFESSIONALS IN COIMBATORE CITY

Dr. M. SURESH
Assistant Professor
CMS Institute of Management Studies,
Chinnavedampatti, Coimbatore- 641 049
Tamil Nadu, India.

Abstract: This analysis focuses on the impact of organizational citizenship behavior among working women employees at information technology professionals in Coimbatore city. Organizational Citizenship Behavior has gained a lot of importance as they promote efficiency in organizational functioning. Employers all across the world are working hard to keep their workers happy and engaged. Employees that are happy in their jobs have a high level of commitment to their company and are highly motivated. The researcher used various research tools such as Descriptive analysis, T-test, ANOVA, Chi-Square analysis, and SEM hence it is concluded that organizations should focus on instilling emotional stability in the minds of Women Information Technology Professionals, adopt suitable strategies to strengthen effective culture in any organization, make suitable amendments in the existing policy to increase the satisfaction among employees and resort to innovative techniques of counseling to inculcate the essence of commitment in the minds of the employees.

I. INTRODUCTION

The concept of Organizational Citizenship Behaviour has gained a lot of importance as they promote efficiency in organizational functioning. Employers all across the world are working hard to keep their workers happy and engaged. Organizations are attempting to improve their environmental culture by providing flexible work arrangements, treating their employees with respect, and adequately compensating them for their hard work, among other things. A high-performance organization evolves by persistence, by treasuring employees' efficiency, and merits, and by providing them with high job satisfaction. The Information Technology industry makes a significant

contribution in terms of both economic and employment prospects. In order to improve societal standards, an increasing number of students are focusing on Information Technology related subjects.

II. REVIEW OF LITERATURE

Bateman and Organ (1983)¹ emphasized the typical notion that "satisfaction causes performance" which is regarded as naive folk wisdom and does not have empirical support. They suggested using other conceptions of performance rather than traditionally defined measures such as quantity and quality of output. The measure of performance used in the study is "citizenship behavior". 77 employees and supervisors were surveyed at two separate times at a major Midwestern State University. Citizenship behavior is reported by the immediate superior of each employee and employees reported their level of satisfaction from all components of a job such as work, promotion, pay, coworkers, and supervision. The findings of the study highlight a significant positive relationship between JS and OCB.

Bateman and Organ (1983)² operationalized OCB as the "lubricator of the organization's social machinery" but the behavior is not mandatory because it does not comprise task performances. Examples of such behavior are: helping coworkers with a job-related problem; tolerating temporary impositions without complaint; making timely and constructive statements about the work unit or its head to outsiders. They conceptualized OCB as a one-dimensional construct.

Smith, Organ and Near (1983)³ inquired about the characteristics and precursors of citizenship behavior by using 220 employees and 202 supervisors from two banks. Based on factor analysis, it has been contended that there are at least two distinct classes of citizenship behavior



Altruism and Generalized Compliance. The exploration of social psychological literature suggested that the characteristic of mood state influences the probability of prosocial behaviors. Job satisfaction has been used as a measure of chronic mood state in the study which has a direct prediction impact on altruism.

Smith, Organ, and Near (1983)⁴ explained that the behaviors do not have the same motivational bases as the performance of the formal job. Moreover, the behaviors are not governed by individual incentive schemes because of subtleness and difficulty in measurement. However, consistent engagement in such behaviors affects the subjective appraisal of officials. After five years Organ (1988) conceptualized OCB more comprehensively and concretely. Organ defines OCB as discretionary behavior, not accounted to reward formally, and benefits the organization by increasing its effectiveness

Organ and Konovsky (1989)⁵ compared the importance of subjective appraisal of one's job (Cognitive) and mood states (Affective) in predicting organizational citizenship behavior. The sample was drawn out from employees working in two privately owned hospitals. Results reveal that OCB (rated by supervisor) is more uniquely explained by cognitive appraisal of one's job

Research Gap

Even though there are so many studies related to the Organizational Citizenship Behaviour of Information Technology Professionals, there is no exclusive study on the Organizational Citizenship Behaviour of Women Information Technology Professionals. Hence, the present study has made an attempt to fill up the research gap.

Statement of the Problem

The efficiency and productivity of the organizations are influenced by this Organizational Citizenship Behaviour. Developing the Organizational Citizenship Behaviour among the employees of the Information Technology sector will help to exist in this competitive world and also retain the employees and hence reducing the rates of turnover and absenteeism by the creation and maintenance of a supportive and friendly work atmosphere in the workplace.

Research Questions:

1. What are the demographic factors of the Women Information Technology Professionals that influence Organizational Citizenship Behaviour?
2. What is the impact of organizational citizenship behaviour on employee performance?
3. What management practice will improve the Organizational Citizenship Behaviour among the Women Information Technology Professionals?

Objectives of the Study

1. To analysis the demographic profile of the Women Information Technology Professionals.

2. To find the differences between the demographic profile of the Women Information Technology Professionals and various dimensions of Organizational Citizenship Behaviour.
3. To study the various factors responsible for Organizational Citizenship Behaviour and Employee Performance of Women Information Technology Professionals

Hypotheses of the study.

Ho – There is no significant difference between demographic profiles of the Women Information Technology Professionals with respect to Organizational Citizenship Behaviour.

Ho – There is no significant difference between demographic profiles of the Women Information Technology Professionals with respect to Employee Performance.

Ho – There is no significant relationship among various dimensions of Organizational Citizenship Behaviour of Women Information Technology Professionals.

Scope of the Study

The Women Information Technology Professionals of top 10 IT companies working in Coimbatore: Capgemini, Cognizant Technology Solutions, Tata Consultancy Services, Zoho, UST Global, Plintron Global Technologies, Hexaware Technologies, DXC Technology, and Altran were covered under the scope of the study.

III. RESEARCH METHODOLOGY

The research methodology shows the ways and means to be followed in the research activities starting from investigation to presentation of research report. It includes the research design of the study, profile of the study area, sampling framework of the study, sources of data, construct development of the study, framework of analysis and limitations.

Research Design of the Study

A research design is a framework for guiding a research project. It describes the procedures essential for obtaining the information required to structure and/or solve the research problems.

Sampling Framework of the Study

The sampling framework of the study consists of the determination of sample size and sampling procedure of the study. Sample size = 387 In this study, the researcher took samples from the population.

Sampling Procedure of the Study

There are 524 Women Information Technology Professionals are taken as a sample for the present study. Seven hundred and fifty questionnaires were distributed equally among the top ten Information Technology



Companies in Coimbatore city.

literature.

Sources of Data

The present study is wholly based on the **primary data**. The primary data was collected personally with the help of a structured questionnaire. The **secondary data** collected from the books, journals, and magazines were used to form the theoretical framework of the study and the review of the

Tools used:

Descriptive Analysis, Correlation Coefficient standard deviations. Karl Pearson developed coefficient from a similar coefficient Independent Sample ‘t’ Test Analysis of Variance (ANOVA) Multiple Regression Analysis and Structural Equation Modelling (SEM).

IV. ANALYSIS AND INTERPRETATION OF DATA

S.No	Variables	Factors	Frequency	Percentage
1	Age	Below 30 Years	231	44.1
		31 - 50 Years	283	54.0
		Above 50 Years	10	1.9
		Total	524	100.0
2	Gender	Male	278	53.0
		Female	246	47.0
		Total	524	100.0
3	Marital Status	Married	410	78.2
		Un-Married	114	21.8
		Total	524	100.0
4	Educational Qualification	Undergraduate	208	39.7
		Postgraduate	263	50.2
		Professional	42	8.0
		Certificate Course	11	2.1
		Total	524	100.0
5	Experience	Below 3 Years	71	13.5
		3 – 6 Years	166	31.7
		7 – 10 Years	138	26.3
		Above 10 Years	149	28.4
		Total	524	100.0
	Family Size	Below 4	302	57.6
		4 – 6	201	38.4



6.		Above 6	21	4.0
		Total	524	100
7.	Income	Below Rs.25,000	82	15.6
		Rs.25,001 to Rs.35,000	253	48.3
		Rs.35,001 to Rs.45,000	93	17.7
		Above Rs.45,000	96	18.3
		Total	524	100
8.	Designation	Programmers	50	9.5
		Software Testers	42	8.0
		Network admins	10	1.9
		Human Resource	189	36.1
		Others	233	44.5
		Total	524	100

Ranking for Courtesy Factor

Courtesy	Mean	Std. Deviation	Skewness	Kurtosis
Send an Anniversary greeting to your colleague	4.14	.806	-.738	.120
Get Coffee/Tea for your co-workers when you get your own	4.14	.827	-.909	.530
Empathizes with personal problems of employees	4.06	.837	-.737	.123
Assist staff in making copies or submitting faxes	3.92	.866	-.387	-.586
Get food when colleagues are busy with work and can't move to lunch	3.91	1.021	-1.223	1.198



Assist co-workers in moving office files/things	3.91	.942	-1.017	.898
Buy a gift for the birthday of a co-worker child	3.88	1.031	-.961	.625
Support co-workers personally to reach their destination after work	3.86	.938	-.297	-.907
Adapt the needs of co-workers by cancelling planned personal work	3.65	.952	-.240	-.850
Accommodate out of town workers for shopping or personal jobs	3.33	1.063	.192	-1.203

The above table shows that “Send an Anniversary greeting to your colleague” is the top ranked Courtesy factor with a mean value of 4.14, “Get Coffee/Tea for your co-workers when you get your own” is the second ranked . third ranked Courtesy factor with a mean value of 4.06, “Assist staff in making copies or submitting faxes” is the fourth ranked Courtesy factor with a mean value of 3.92, “Get food when colleagues are busy with work and can't move to lunch” is the fifth ranked Courtesy factor with a mean value of 3.91, “Assist co-workers in moving office files/things” is the sixth ranked Courtesy factor with a mean value of 3.91, “Buy a gift for the birthday of a co-worker child” is the seventh ranked Courtesy factor with a mean value of 3.88, “Support co-workers personally to reach their destination after work”

is the eighth ranked Courtesy factor with a mean value of 3.86, “Adapt the needs of co-workers by cancelling planned personal work” is the ninth ranked Courtesy factor with a mean value of 3.65 and “Accommodate out of town workers for shopping or personal jobs” is the tenth ranked Courtesy factor with a mean value of 3.33.

Impact of various dimensions of Organizational Citizenship Behaviour on Employee Performance of Women Information Technology Professionals

Unstandardized Estimates

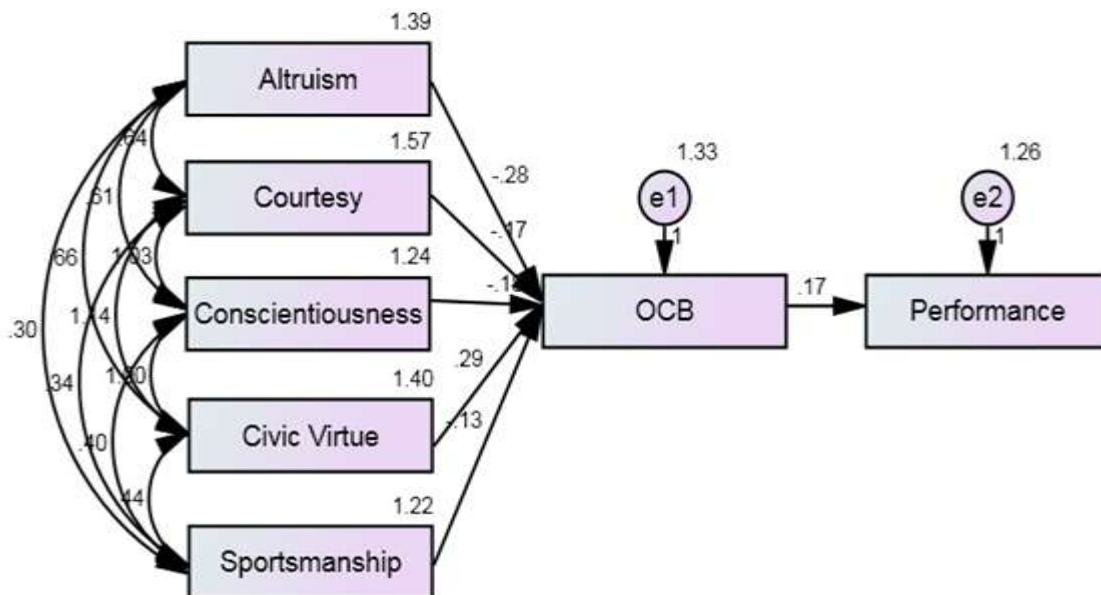



Standardized Estimates

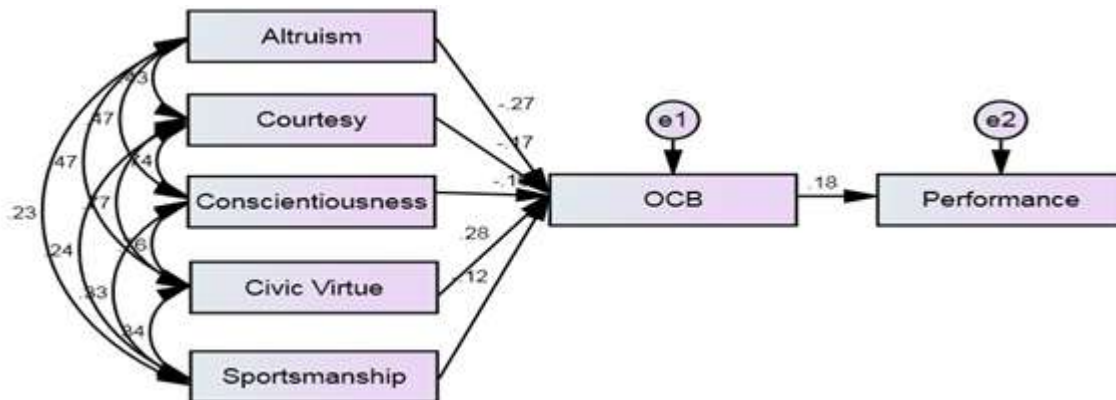

Overall, the above model shows satisfactory explanatory power for Impact of various dimensions of organizational citizenship behaviour on employee performance of women information technology professionals. As there is no consensus on the appropriate method of determining overall goodness-of-fit a number of measures were calculated to assess this. Five measures were utilized to determine the absolute fit of the model; the goodness of fit index (GFI),

the adjusted goodness-of-fit index (AGFI), the root mean squared error of approximation (RMSEA) the chi-square goodness-of-fit test (χ^2) and the ratio of χ^2 to degrees of freedom (χ^2 / df). Three measures were utilized to determine the incremental fit of the model; the comparative fit index (CFI), the non-normed fit index (NNFI) and the incremental fit index (IFI).

Impact of Organizational Citizenship Behaviour on Employee Performance

Path	Estimate	S.E.	C.R.	P
OCB <--- ALT	-.282	.050	-5.677	0.000**
OCB <--- COU	-.170	.069	-2.476	0.013*
OCB <--- CON	-.185	.077	-2.409	0.016*
OCB <--- CV	.294	.077	3.840	0.000**
OCB <--- SPORT	-.134	.049	-2.738	0.006**
EP <--- OCB	.168	.039	4.272	0.000**

** Significant at 1 percent level.

Model Fit Statistics

Goodness of Fit Statistics	Values
Chi Square Value (CMIN)	54.333
Degree of Freedom (Df)	5
Chi Square / Df (CMIN/Df)	10.867
Goodness of Fit Index (GFI)	0.973
Root Mean Square Error of Approximation (RMSEA)	0.065
Adjusted Good of Fit Index (AGFI)	0.846



Comparative Fit Index (CFI)	0.964
Normed Fit Index (NFI)	0.961

Browne & Cudeck (1993) study indicates the model fit can be checked by RMSEA which is less than 0.08 has a good fit and less than 0.05 has a closer fit. Chin and Todd (1995) study proposed that for goodness of model fit GFI (Goodness of Fit Index) and NFI (Normed Fit Index) should be above 0.9 and AGFI (Adjusted good-of-fit Index) should be above 0.8. Bentler (1990) study suggest for good model fit CFI (Comparative Fit Index) should be greater than 0.9. The goodness of final model fit has been shown in above table. As per the various model fit statistics indicates that model was good fit.

V. FINDINGS, SUGGESTIONS AND CONCLUSION

The present study focuses on Organizational Citizenship Behaviour on Employee Performance of Women Information Technology Professionals in Coimbatore city. This is classified into four important parts.

- 39.7% of respondents are Undergraduate, 50.2% of respondents are strgraduate, 8.0% of respondents are Professional and 2.1% of respondents are Certificate Course. This point out that majority of the respondents are Postgraduate. 13.5% of respondents are Below 3 Years, 31.7% of respondents are 3 - 6 Years, 26.3% of respondents are 7 - 10 Years and 28.4% of respondents are Above 10 Years. There is significant difference among Educational Qualification with regard to the dimension of She fulfills assigned duties accordingly, She participates in behaviors that would have a significant effect on her success evaluation, She fails to accomplish essential duties. Maintain clean workplace” is the top ranked Conscientiousness
- factor with a mean value of 4.46, “Offer prior notice to ensure smooth operation of the job” is the second ranked Conscientiousness factor with a mean value of 4.34, “Ends the work on time” is the third ranked Conscientiousness factor with a mean value of 4.20.
- Maintain clean workplace, Work late in the evening to finish work, Come to office even in adverse conditions, During the weekend, take urgent work home and complete it and Go to the office even with sick to complete the job.

SUGGESTIONS

- The Managers apart from routine work shall ensure that they spend focused time with their subordinates in knowledge sharing sessions and mentoring the employees on the company’s growth and performance.
- Manager can expose employees to view the work in a conceptual manner. It helps to gain the Manager trust.
- The Management should stretch the fair perception

among employees always and be extra sensitive to interactional justice. Transparent communication to all rather than restricting to certain employees/groups will open up the perception of common practice to all Information.

- While there remain several formulating changes suggested for the management and the organization, the employees due to technical advancements are found to be exceedingly interactive with the gadget sand social media in an unproductive way during operational hours as it is available at their fingertips. Technology Professionals.

VI. CONCLUSION

The importance of Organizational Citizenship Behaviour of Women Information Technology Professionals has gained much eminence in Information Technology industry however there are some dimensions of Organizational Citizenship Behaviour which needs to be studied in depth in order to measure their influence on Organizational Citizenship Behaviour The attrition rate of any organization is very important, in particular in Information Technology industry as it deals with legacy tools, applications. The personnel’s are duly trained to perform their duties. In order to survive, Organizational Citizenship Behaviour aspects are important for any management to thrive and survive. This study reveals all the independent variables have significant influence on Organizational Citizenship Behaviour.

Scope for Further Research

It is imperative to study the time spent by Women Information Technology Professionals during working hours on gadgets in an unproductive way and its impact on individual and Organizational performance. Future research can be examined on a wider area extending to other districts in Tamilnadu. The future study may also include the personality characteristics of the Women Information Technology Professionals, commitment level and organizational development with Organizational Citizenship Behaviour.

VII. BIBLIOGRAPHY

[1]. Bateman: T. S.& Organ. D. W. (1983) Job Satisfaction and the Good Soldier: The Relationship between Affect and Employee “Citizenship”. The Academy of Management Journal, 26(4), (pp. 587-595).

[2]. Smith, C. A. Organ, D. W.& Near, J. P. (1983) Organizational Citizenship Behavior: Its Nature and Antecedents. Journal Applied Psychology, 68(4),



- (pp.653-663).
- [3]. Organ, D. W: & Konovsky. M. (1989) Cognitive versus affective determinants of organizational citizenship behaviour: *Journal of Applied Psychology*, 74(1), pp.157-164. ”, *Management Science Letters*, 10,(pp. 1107-1114).
 - [4]. Rub A. A. : & Fawzi, R. (2004) Job stress, Job Performance, and Social Support among Hospital Nurses. *Journal of Nursing Scholarship*, (pp 36(1).
 - [5]. Runhaar, P., Judith, K.,:&Sanders, K. (2013) Teachers’ organizational citizenship behavior: Considering the roles of their work engagement, autonomy, and leader-member exchange. *Teaching and Teacher Education*. (30, 99-108).

IJEAST

INTERNATIONAL JOURNAL
OF ENGINEERING APPLIED SCIENCE
AND TECHNOLOGY

ABOUT IJEAST

International Journal of Engineering Applied Science and Technology (IJEAST) is a peer-reviewed, open access journal that publishes high-quality research papers in the field of Engineering, Applied Science and Technology.

IJEAST aims to provide a platform for researchers, academicians, and professionals to share their innovative ideas, research findings, and practical experiences with the global scientific community.

FOCUS AREAS

- Engineering
- Applied Science
- Technology
- Innovation & Development
- Interdisciplinary Studies



PEER REVIEWED

All submissions are rigorously peer reviewed to ensure quality.



OPEN ACCESS

Free and unrestricted access to research for all.



GLOBAL REACH

Connecting researchers and professionals worldwide.



TIMELY PUBLICATION

We ensure a swift and efficient publication process.



For more information, visit our website

www.ijeast.com



INTERNATIONAL JOURNAL
OF ENGINEERING APPLIED SCIENCE
AND TECHNOLOGY

✉ editor@ijeast.com

🌐 www.ijeast.com

📍 India



2455-2143