



IJEAST

INTERNATIONAL JOURNAL
OF ENGINEERING APPLIED SCIENCE
AND TECHNOLOGY



VOLUME : 2 ISSUE : 5 Print / Issue Publication Date: 11-Aug-2017



ISSN : 2455-2143



Indexed In



WWW.IJEAST.COM

editor@ijeast.com



PV POWERED HIGH GAIN DC/DC CONVERTER WITH DUAL COUPLED INDUCTORS

Ajmal M M

PG Scholar, Department of EEE
MACE Kothamangalam,
Kerala, India.

Benny Cherian

Professor, Department of EEE
MACE Kothamangalam,
Kerala, India

Bindu Elias

Professor, Department of EEE
MACE Kothamangalam,
Kerala, India

Abstract—Photovoltaic power generation is evolving as one of the most remarkable renewable energy sources because of its benefits like eco-friendly nature, less maintenance. The output voltage of a PV module is usually low. Hence high power high voltage step up DC/DC converters are required to deliver the produced electrical energy to the load. Here a high voltage gain DC/DC converter with dual coupled inductor is presented for PV applications. The primary windings of two coupled inductors are connected in parallel. They share the input current and reduce the current ripple at the input. The converter has low input current ripple because of the interleaved control adopted. Voltage stress across semiconductor switches are low compared to conventional boost converter. The secondary sides of two coupled inductors are connected in series to a voltage multiplier module to increase the voltage gain. Also, the active switches are turned on at zero current. MPPT is used to maximize the efficiency of PV array. Perturb and Observe (P&O) method and Fractional Open Circuit (FOC) voltage method of Maximum Power Point Tracking (MPPT) are simulated in MATLAB/SIMULINK. FOC voltage method is used in hardware as it is low cost and easy to implement. dsPIC30F2010 microcontroller is used for the control circuit.

Keywords— PV power generation, High voltage gain, Coupled inductor MPPT

I. INTRODUCTION

The usage of energy is increasing day by day. But major energy sources such as fossil fuel have a harmful impact on our environment. Also their shortage is a major problem, the mankind is going to face in nearby future. Solar energy is widely accepted as an effective and efficient alternative for conventional energy resources. The fundamental unit of a Photo Voltaic (PV) generating system is a PV module. The output voltage of a PV module is usually low. Hence a boost converter is used with the PV module to boost the output voltage for commercial applications. For efficient use of solar power under different irradiance, it is also important to extract maximum power from the solar module. Maximum power is extracted from the module by operating it in the maximum power operating point either by adjusting the duty ratio of the converter or the frequency. A number of Maximum Power Point Tracking (MPPT) methods are available nowadays[1].

Perturb and Observe (P&O) method and Fractional Open Circuit (FOC) methods are two widely adopted MPPT methods. P&O is known for effective tracking of MPP, while FOC method is well known for its simplicity in implementation and fast operation [2]-[3]. Theoretically, a basic boost converter is capable of providing high conversion ratio, but extremely high duty ratio is required. In practice, extreme duty ratios are not permitted because of the large conduction losses and frequent damage of power switches. Usually it is preferable to use low voltage rated power switches having low on state resistance to reduce the conduction losses, which may not be possible in a conventional boost converter. Cascaded boost converters can provide high voltage gain [13]. But high voltage stress across the switches and poor efficiency are the disadvantages. DC/DC converters using coupled inductors is a good alternative to obtain a high step up gain [7], provided the leakage inductances are handled properly. Interleaved control is found very useful in reducing the input current ripple of the converter [8]-[10]. Two different boost converter structures can be combined to produce twice the voltage gain by connecting their inputs in parallel and output in series. The two independent inductors of this combined converter is replaced by two coupled inductors. Connecting the primary windings of coupled inductors in parallel and secondary windings in series a novel high step up DC/DC converter can be derived [11]. An input parallel output series boost converter with dual coupled inductors can be used for high step up and high power applications. This converter has the merits of high voltage gain, low voltage stress across the power switches and reduced output voltage ripple. Also, the converter can turn on the active switches at zero current and hence reduce switching losses. The converter can be effectively powered by a solar source and maximum power can be extracted from the module by implementing suitable maximum power point tracking algorithm.

II. PV POWERED HIGH GAIN DC/DC CONVERTER WITH DUAL COUPLED INDUCTORS

The proposed system is shown in Fig. 1. The low PV output voltage is stepped up into high voltage with the help of a high voltage gain DC/DC converter with dual coupled inductors.



MPPT system is implemented to track the maximum power point of the solar module for improved efficiency.

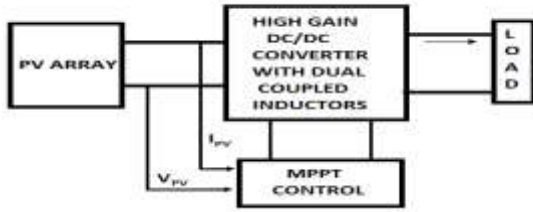

Fig. 1. PV Powered high gain DC/DC converter

A. DC/DC Converter with dual coupled inductors-

The high voltage gain DC/DC converter with dual coupled inductor is shown in Fig. 2.

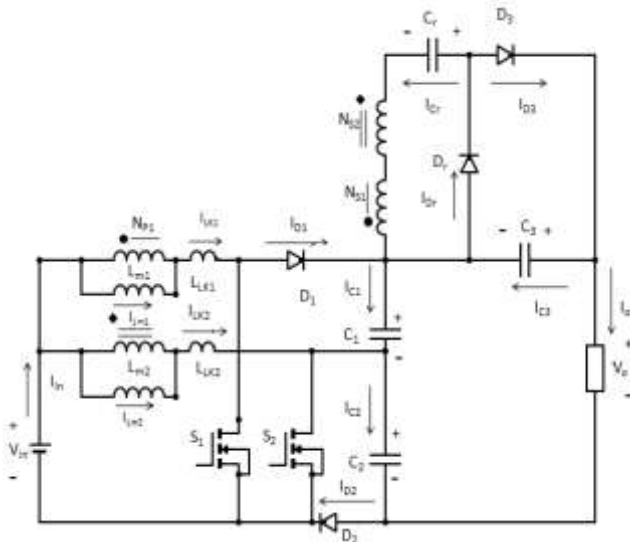

Fig. 2. DC/DC converter using dual coupled inductors

Where S_1 and S_2 are power switches. C_1, C_2, C_3 are filter capacitances. L_{k1} and L_{k2} are the leakage inductance and L_{m1} and L_{m2} are the magnetizing inductances of coupled inductors 1 and 2 respectively. The advantages of the converter over conventional boost converter are high voltage gain, low voltage stress across power switches and low input current ripple. The switches of the converter are turned on at zero current due to the leakage inductance of the coupled inductors. The switches are supplied with interleaved overlapped pulses to operate the converter in continuous conduction mode. The voltage gain of converter can be obtained by solving the volt second balance across the mutual inductances as given in equation 1 [11].

$$m_{CCM} = \frac{2(kN+1)}{1-D} \quad (1)$$

Where k is the coupling coefficient, N is the turns ratio of coupled inductance and D is the duty ratio. And the voltage stress across power switches for an output V_o can be obtained as,

$$V_{S1} = V_{S2} = \frac{V_o}{2(1+N)} \quad (2)$$

B. Perturb & Observe MPPT algorithm-

The P&O is probably the most often used MPPT algorithm today. It is based on the fact that the derivative of power in function of voltage is zero at maximum power point. The implementation of algorithm is as shown in Fig. 3. The voltage and current of solar module is read. Power is calculated and is compared with the previous value. Further, the duty ratio is changed in the increasing direction of power. The final operating point will oscillate around the maximum power point of solar module

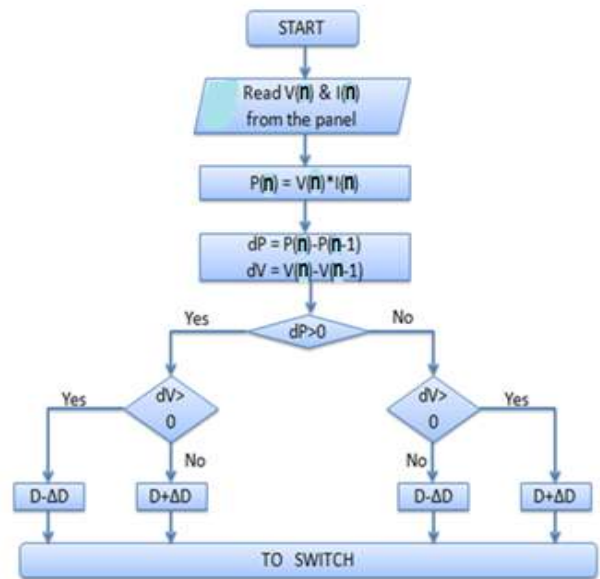

Fig. 3. P&O MPPT algorithm

C. Fractional Open Circuit MPPT algorithm-

This is one of the simplest MPPT methods. The fractional open circuit voltage based MPPT utilizes the fact that the PV array voltage corresponding to the maximum power exhibits a linear dependence with respect to array open circuit voltage for different irradiation and temperature levels. I.e; $V_{MPP} = M_V \cdot V_{OC}$, where V_{MPP} is the voltage at maximum power point V_{OC} is the open circuit voltage of a PV module and M_V is known as voltage factor, which is usually between 0.7 to 0.8 depending upon the PV array characteristics. To operate the PV panel at MPP, the PV voltage is compared with a reference voltage corresponding to V_{MPP} . The error signal is further processed to make $V_{PV} = V_{MPP}$, by adjusting the duty ratio of the converter. The flow chart explaining FOC algorithm is shown in Fig. 4.

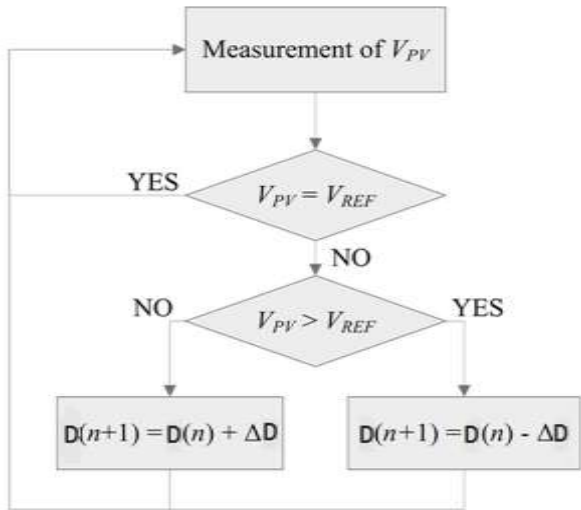

Fig. 4. FOC MPPT algorithm

III. SIMULATION RESULTS

The converter as well as the MPPT algorithms are simulated in MATLAB/ SIMULINK.. The SIMULINK model of the converter is shown in Fig .5. The converter is designed for a gain of 10, with a duty ratio of 0.6 and taking turns ratio of coupled inductors as 1. The coupling coefficient is assumed to be 1. The pulse generation circuit is shown as a subsystem. 180° interleaved overlapped pulses are used. The control signals with duty ratio 0.6 are shown in Fig .6. The simulation parameters are shown in table -1.

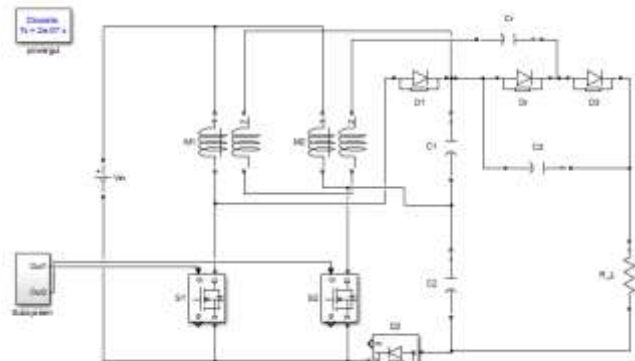

Fig .5. Simulink model IPOS high gain converter

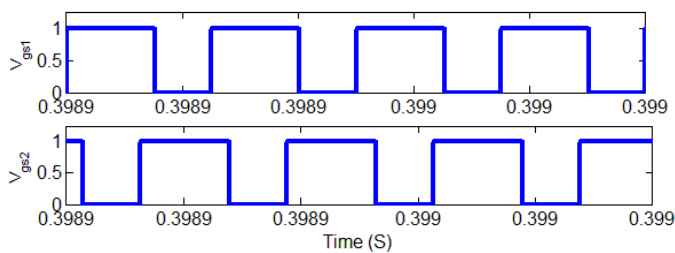

Fig .6. Control pulses of switches

Table -1 Simulation parameters.

Parameter	Value
P_o	100W
V_{in}	20
Magnetizing inductance, L_{m1}, L_{m2}	242 μ H
Capacitors C_1, C_2	47 μ F
Capacitor C_3	100 μ F
Capacitor C_r	10 μ F
Switching frequency, f_s	40kHz
V_{out}	200

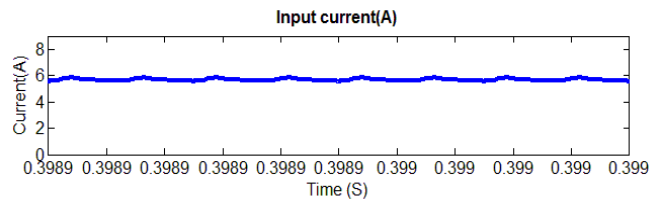

Fig .7. Input current waveform

Fig .7. shows the input current waveform , the input current has got a low ripple of 7.9%. Fig .8 and Fig .9 respectively shows the voltage across and current flowing through the switches 1 and 2. The voltage stress across the switch is one fourth of the output voltage as obtained from equation 2 and switches are turned on at zero current.

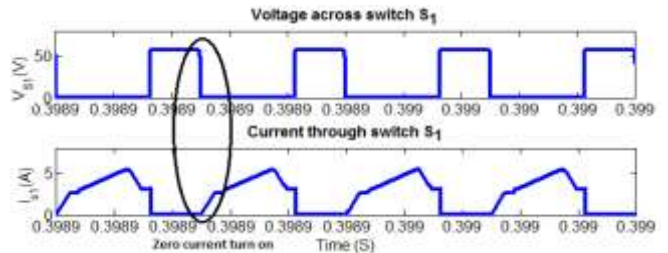

Fig .8. Zero current turn on of switch S₁

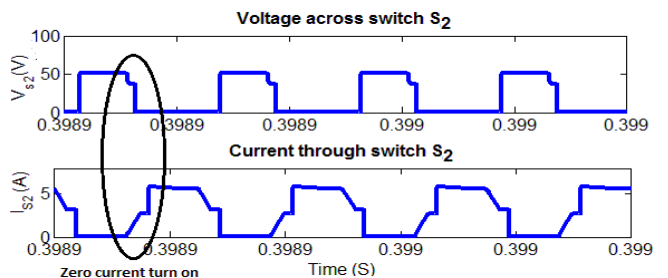

Fig .9. Zero current turn on of switch S₂



It is clear from the waveforms that the switches are turned on with zero current turn on due to the leakage inductance present in the path and hence switching losses are reduced. The output voltage waveform for an input voltage of 20V is shown in Fig . 10. The converter achieves the designed gain of 10.

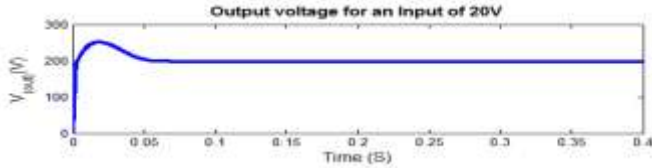

Fig .10. Output voltage waveform

The BP SOLAR SX 3190 is selected as the PV module from the MATLAB tool box to verify the MPPT algorithms. The characteristics of the module is given in Fig . 11.

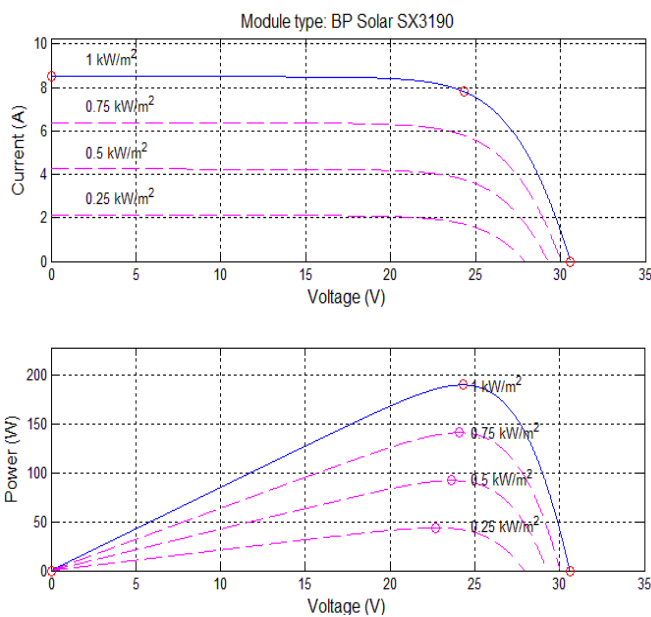

Fig .11. Characteristics of BP Solar SX3190.

From the characteristics it is clear that MPP voltage is 24.3V . The MPP for 1000W/m² is around 180W and that for 500W/m² is 140W. The simulation is done for both irradiances and results are obtained. The simulation results for P & O MPPT is shown in Fig .12. The P & O algorithm is implemented in embedded C program. It is clear that for both 1000W/m² and 500W/m², the panel reaches respective MPPs. P & O algorithm is slow to respond and it requires both current and voltage sensors at the input. Also certain oscillations are present around the final MPP.

The simulation results of FOC MPPT algorithm is shown in Fig. 13. The aim of FOC algorithm is to make the PV voltage equal to that of the voltage at MPP. A voltage sensor is required to measure the PV voltage continuously. The

measured voltage is compared with a reference voltage equal to that of V_{MPP} . The error signal obtained is further processed to generate the duty ratio. From the simulation results it is clear that FOC method tracks the maximum power point under different irradiances. It is a fast method compared to P & O algorithm and there is no oscillations around the MPP. One of the disadvantage of FOC method is that the voltage at maximum power point varies slightly at different irradiances and hence the tracking may not be as accurate as P&O algorithm.

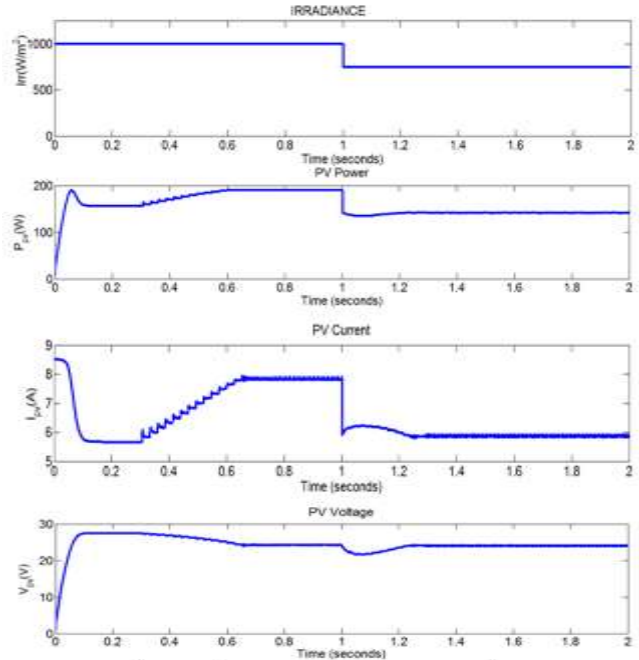

Fig .12. Simulation results P&O MPPT algorithm

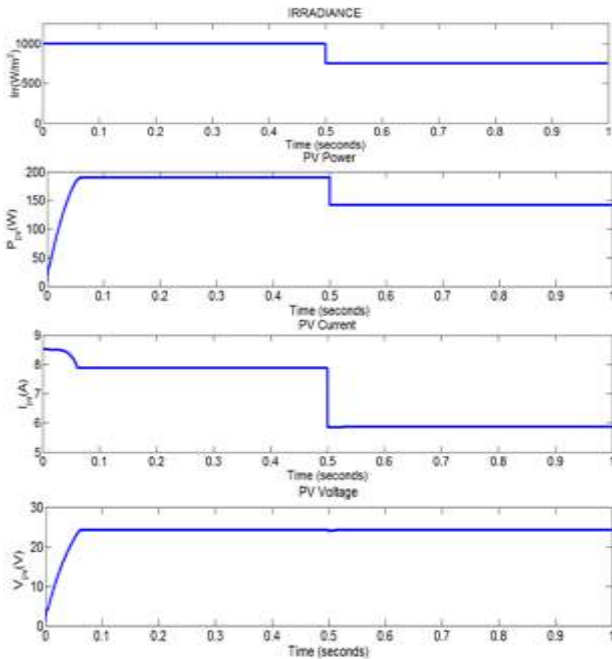

Fig 13. Simulation results FOC MPPT algorithm

IV. EXPERIMENTAL RESULTS

The basic experimental set up is as shown in Fig .14. Both the power circuit and control circuit are supplied from lab power supply. A 40W incandescent lamp is used as the load. dsPIC30f2010 microcontroller is used as the controller.



Fig 14. Experimental set up

The output voltage obtained for an input of 20V is shown in Fig . 15. The multimeter shows the output voltage of 186V .

The practical voltage gain is slightly less than the theoretical one because of the on state resistance of power semiconductor devices and also the leakage inductance of coupled inductor comes into picture.



Fig 15. Experimental result showing voltage gain

The MPPT operation is also verified from the lab power supply. The V_{MPP} is assumed to be 75% of the open circuit voltage. Assuming the open circuit voltage pf 20V, the controller is programmed to make the voltage of the source at 15V. When the controller is turned on at a supply voltage of 20V, the supply voltage is dropped to 15V, hence the MPPT is verified.



Fig 15. Experimental result showing MPPT operation



V. CONCLUSION

An parallel input series output DC/DC converter using dual coupled inductors is found to be a good candidate for low input voltage, high voltage gain applications. The converter can achieve higher voltage gain with low duty ratio. A voltage gain of 10 is obtained by operating at a duty ratio of 0.6 with turns ratio 1. The voltage stresses of the power switches are very low, which is one fourth of the output voltage. Interleaved control reduces the input current ripple effectively. The output voltage ripple is calculated as 0.02%. The simulation results show that main switches can be turned on at zero current. The converter can be effectively used for a solar power application. FOC and P&O MPPT algorithms are implemented with the converter for maximum power extraction from solar module. Simulation and experimental results proves the effectiveness of converter. FOC MPPT is verified from the lab power supply.

VI. REFERENCES

- [1] Hardik P Desai, H K Patel “Maximum power point algorithm in PV generation:an overview”, *7th International Conference on Power Electronics and Drives*, Nov. 2007.
- [2] Jawad Ahmad “A Fractional Open Circuit Voltage Based Maximum Power Point Tracker for Photovoltaic Arrays”, *2nd International Conference on Soft-ware Technology Engineering(ICSTE)*, 2010
- [3] Ali F Murtaza, Hadeed Ahmed Sher, and Chiaberge M “A Novel Hybrid MPPT Technique for Solar PV Applications Using Perturb & Observe and Fractional Open Circuit Voltage Technique”, *2nd MECHATRONICA 15th International Symposium*, 2012
- [4] T. F. Wu, Y S. Lai, J. C. Hung, and Y M. Chen, “Boost converter with coupled inductors and buck-boost type of active clamp”, *IEEE Transactions on Industrial Electronics*, vol.55, no. 1, pp. 154-162, Jan. 2008.
- [5] T. J. Liang, K. C. Tseng, “Analysis of integrated boost-yback step up converter”, *IEE Proceedings electrical power applications*, vol. 152, no. 2, pp. 217-225, Mar. 2005..
- [6] W. Li, Y. Zhao, J.Wu and X. He, “Interleaved high step-up converter with winding cross coupled inductors and voltage multiplier cells”, *IEEE Transactions on Power Electronics*, vol. 27, no. 1, pp. 133-143, Jan. 2012.
- [7] G A. L. Henn, R. N. A. L. Silva, P P. Praca, L H. S. C. Barreto, and D S.Oa, Jr. “Interleaved-boost converter with high voltage gain”, *IEEE Transactions on Power Electronics*, vol. 25, no. 11, pp. 2753-2761, Nov. 2010.
- [8] C. M. Lai, C. T. Pan, and M. C. Cheng “High efficiency modular high step up interleaved boost converter for DC microgrid applications”, *IEEE Transactions Industrial Applications*, vol. 48, no. 1, pp. 161-171, Jan/Feb, 2012.
- [9] Araujo. S. V, Torrico Bascope. R. P, and Torrico Bascope. G. V “Highly efficient high step up converter for fuel cell power processing based on three state commutation cell” *IEEE Transactions Industrial Electronics*, vol.57, no.6, pp.1987-1997, June 2010.
- [10] M. Arun Devi, K. Valarmathi, and R. Mahendran “Design and implementation of interleaved boost converter for fuel cell applications”, *International Journal for Power Electronics and Drive System*, vol.1, no.2, December 2014.
- [11] Xuefeng Hu, Chunying Gong “A high gain input parallel output series DC/DC converter with dual coupled inductors”, *IEEE Transactions on Power Electronics*, vol. 30, no. 3, pp. 1306-1317, March. 2015.
- [12] W. Li and X. He, “A family of interleaved DC/DC converters deduced from a basic cell with winding cross coupled inductors (WCCIs) for high step-up or step-down conversions”, *IEEE Transactions on Power Electronics*, vol. 23, no. 6, pp. 1791-1801, Jun. 2008
- [13] S Vighetti, J P Ferrieux “Optimization and design of a cascaded DC/DC Converter devoted to grid connected photovoltaic systems”, *IEEE Transactions on Power Electronics*, vol. 27, no. 4, pp. 2018-2027, Apr. 2012.
- [14] Muralidhar Killi, Susovon Samanta, “Modified Perturb and Observe MPPT Algorithm for Drift Avoidance in Photovoltaic Systems”, *IEEE Transactions on Industrial Electronics*, vol. 62, no. 9, pp. 5549-5559, Sept. 2015.
- [15] Tarek Selmi, M A Niby, Laura Devis and Andrew Devis “P and O MPPT implementation using MATLAB/SIMULINK”, *9th International Conference on Ecological Vehicles and Renewable Energies*, 2014
- [16] Dr. P S Bimbhra “Power Electronics”, Khanna Publishers Delhi, 2012.
- [17] A. Chakrabarti “Circuit theory (analysis and synthesis)”, Dhanpat Rai and Company

IJEAST

INTERNATIONAL JOURNAL
OF ENGINEERING APPLIED SCIENCE
AND TECHNOLOGY

ABOUT IJEAST

International Journal of Engineering Applied Science and Technology (IJEAST) is a peer-reviewed, open access journal that publishes high-quality research papers in the field of Engineering, Applied Science and Technology.

IJEAST aims to provide a platform for researchers, academicians, and professionals to share their innovative ideas, research findings, and practical experiences with the global scientific community.

FOCUS AREAS

- Engineering
- Applied Science
- Technology
- Innovation & Development
- Interdisciplinary Studies



PEER REVIEWED

All submissions are rigorously peer reviewed to ensure quality.



OPEN ACCESS

Free and unrestricted access to research for all.



GLOBAL REACH

Connecting researchers and professionals worldwide.



TIMELY PUBLICATION

We ensure a swift and efficient publication process.



For more information, visit our website

www.ijeast.com



INTERNATIONAL JOURNAL
OF ENGINEERING APPLIED SCIENCE
AND TECHNOLOGY

✉ editor@ijeast.com

🌐 www.ijeast.com

📍 India



2455-2143