



IJEAST

INTERNATIONAL JOURNAL
OF ENGINEERING APPLIED SCIENCE
AND TECHNOLOGY



VOLUME : 4 ISSUE : 08 Print / Issue Publication Date: 11-Feb-2020



ISSN : 2455-2143



DOI : 10.33564/IJEAST.2019.v04i08.022

Indexed In



WWW.IJEAST.COM

editor@ijeast.com

LIFI TECH FOR SCUBA DRIVER COMMUNICATION UNDER WATER

Ajoy Kumar

B. Tech student, Department of computer science and engineering
Ram Krishna Mahato Government Engineering College,
Purulia, West Bengal, India

Abstract:- Scuba driver face a great challenge in the field of communication under water. For the communication purpose, they use hand signal or hand sign which is very difficult to understand and having life risk. To get rid of this Problem, we should use LIFI (Light Fidelity) technology. LIFI use light waves for the communication purpose and under water it can be used. We try to use lifi here for the communication between scuba drivers. Scuba driver already bring light with them and we use that light only to send voice message to the other scuba. We use a microphone which capture voice from the scuba and the light waves deliver this message to the nearby scuba. It is quite helpful for the scuba communication.

Key word: LIFI (Light Fidelity)

I. INTRODUCTION

Today we can't imagine a world without internet, wifi etc. Internet, wifi all these makes our life easier. We can send a text, voice and even video message in a few second to who sit at thousand miles far.

Then in 2011, Harald Hass discovered lifi (light fidelity). In his TED talk he explain and demonstrated all about the lifi, it actually work with light waves just like the wifi technology work with radio waves.

In simple language data can be send through the light signal.

But still now Scuba driver use hand signal to communicate each other under water because wifi that means radio waves or signal is not working under water. But now no more hand signal, we can use lifi technology. lifi send data or information as the speed of light for that it is quite useful.

II. EXISTING SYSTEM

Our first stage of communication revolution starts with the hand sign. And now we can't think a world without internet, wifi etc.

But even now today's technology fails in communicating under water for scuba driver. We have no such method or technology which can help us in this problem.

The only method we use to communicate is hand sign. It is the only method through they can understand one another.

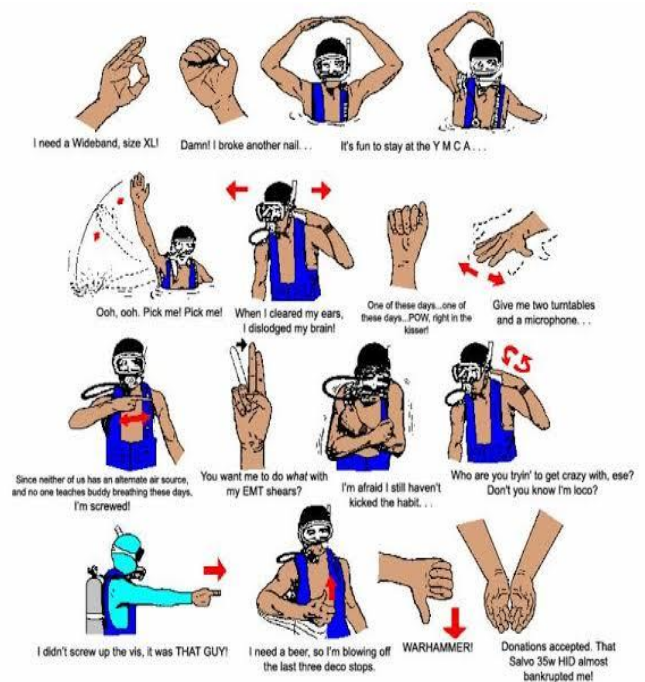

Fig.1

All above hand signals are used by scuba.

III. PROBLEM WITH THE EXISTING SYSTEM

Now we discuss all the problem faced by scuba driver with the existing system that is communication through hand sign.

1. During night diving Scuba have to face difficult to understand the hand sign due to absence of light.

Fig. 2 explain the problem properly



Fig. 2

- Scuba driver have to face the same problem where sunlight can't penetrate through water.

Fig no: 03 explain the problem properly

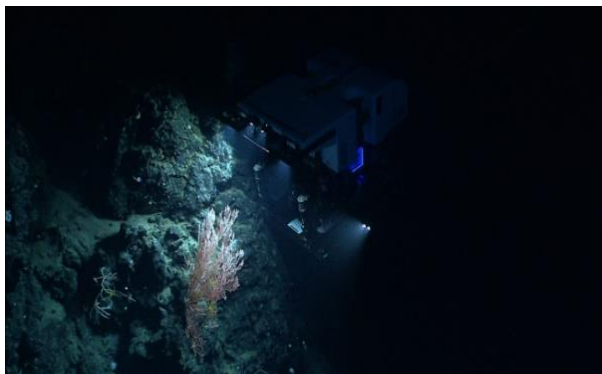

Fig. 3

- Scuba driver have to bring limited oxygen with them and this communication method take much time to understand the other scuba.
- Those entire problems increase the life risk of a scuba driver.

Proposed System

In proposed system we will use lifi technology in place of hand sign. Which allow the scuba to communicate with other scuba with Voice.

The main problem I faced to establish this proposed system is about a matter that scuba can't talk under water because an oxygen mask is attached with their mouth.

Fig. 4 explain it.



Fig. 4

But to get rid of this problem we have to use a scuba helmet which allows them to breath under water. But now many companies develop such scuba helmet which allows them to breathe inside water freely.



This is the scuba helmet which allow them to breath inside their helmet.

Here we use such type of scuba helmet for lifi communication.

Architecture of proposed system

Here we have to use such scuba helmet which allows us to breathe freely inside water it means we can also talk inside our scuba helmet.
 Now we use this concept to develop our proposed system like that below.

Transmitter scuba

We will connect a microphone with a circuit inside our scuba helmet.

Here is the circuit diagram

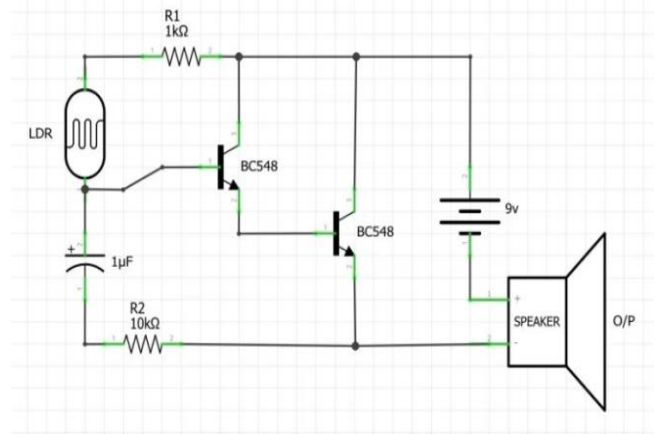

To receive the light waves we can use LDR or SOLAR PANEL as a receiver.

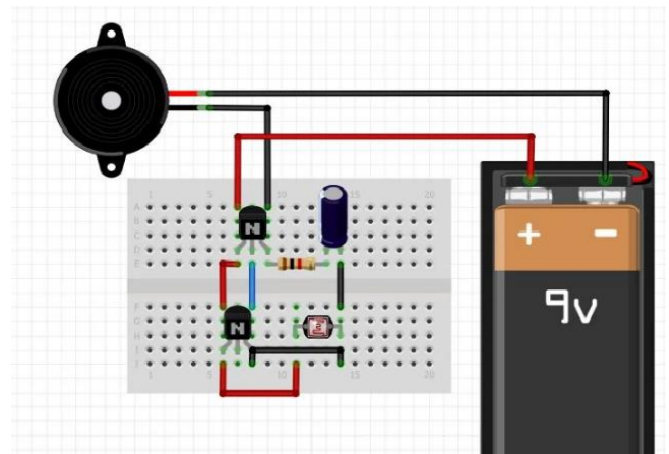
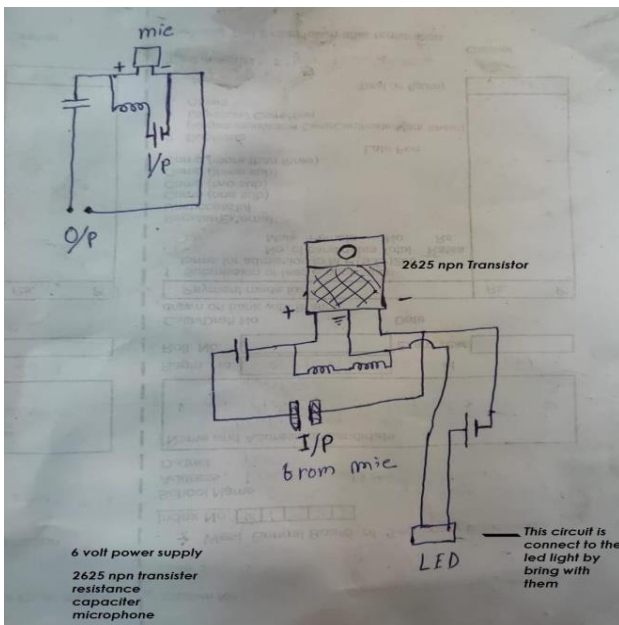

When scuba say something for the other scuba like move forward, wait etc inside the helmet then the microphone absorb this voice and then we will transfer this voice message to the other scuba through the light they bring during diving. Actually we will connect that microphone circuit with the light and for that the voice message gets converted into light waves.

Receiver scuba

The other scuba driver will be the receiver scuba with respect to the first scuba.

We will connect this following circuit with a headphone and receiver for the receiver scuba inside its helmet.





The above fig properly explains how scuba will communicate through lifi technology

IV. CONCLUSION

Here lifi play its core role to improve the performance of scuba communication method. Lifi allow the scuba driver to send them voice message and for that it also decrease the life risk of scuba during diving.

V. ACKNOWLEDGEMENT

I thank my faculties and my superior tutors for their grateful help over making this paper.

VI. REFERENCES

1. <https://en.wikipedia.org/wiki/Li-Fi>
2. <https://www.leisurepro.com/blog/scuba-guides/underwater-communication-for-scuba-divers/>
3. <https://www.divein.com/articles/orb-dive-helmet-is-this-the-future-of-scuba/>
4. <http://www.tuvie.com/futuristic-orb-scuba-diving-helmet-allows-you-to-breathe-underwater-without-heavy-equipment/>
5. <http://www.warse.org/pdfs/2014/icetetsp25.pdf>
6. http://onlinejournal.in/IJIR_V216/006.pdf
7. www.oledcomm.com
8. https://www.ijarcse.com/docs/papers/volume_5/6_june2015/v516-0175.pdf
9. <http://www.ijsrp.org/research-paper-0416/ijsrp-p5275.pdf>
10. http://www.ijarcase.com/dos/papers/volume_3/11_November2013/V3I11-0434.pdf
11. W.-L. Jin, "SPIVC: A Smartphone based inter vehicle communication system," Proceedings of Transportation Research Board Annual Meeting, 2012.
12. N. M. Husain Fidvi, "Car to Car Communication System," source: car communication system.
13. M. A. Chancey, "Short range underwater optical communication links," Master's thesis, North Carolina State University
14. "Underwater Optical Wireless Communication," Hemani Kaushal, (member of IEEE), Georges Kaddoum (member of IEEE) dept of Electronics Communication and Engineering, NorthCap university, Gurgaon India.

IJEAST

INTERNATIONAL JOURNAL
OF ENGINEERING APPLIED SCIENCE
AND TECHNOLOGY

ABOUT IJEAST

International Journal of Engineering Applied Science and Technology (IJEAST) is a peer-reviewed, open access journal that publishes high-quality research papers in the field of Engineering, Applied Science and Technology.

IJEAST aims to provide a platform for researchers, academicians, and professionals to share their innovative ideas, research findings, and practical experiences with the global scientific community.

FOCUS AREAS

- Engineering
- Applied Science
- Technology
- Innovation & Development
- Interdisciplinary Studies



PEER REVIEWED

All submissions are rigorously peer reviewed to ensure quality.



OPEN ACCESS

Free and unrestricted access to research for all.



GLOBAL REACH

Connecting researchers and professionals worldwide.



TIMELY PUBLICATION

We ensure a swift and efficient publication process.



For more information, visit our website

www.ijeast.com



INTERNATIONAL JOURNAL
OF ENGINEERING APPLIED SCIENCE
AND TECHNOLOGY

✉ editor@ijeast.com

🌐 www.ijeast.com

📍 India



2455-2143