



IJEAST

INTERNATIONAL JOURNAL
OF ENGINEERING APPLIED SCIENCE
AND TECHNOLOGY



VOLUME : 1 ISSUE : 7 Print / Issue Publication Date: 09-Oct-2016



ISSN : 2455-2143



Indexed In



WWW.IJEAST.COM

editor@ijeast.com



GRID-CONNECTED PV-FC HYBRID SYSTEM POWER CONTROL USING MPPT AND BOOST CONVERTER

B. Jagadish Kumar
Associate Professor

Dept. of Electrical and Electronics Engineering
Kits WGL, Warangal (T.S), India

K. Vyshnavi Sai Sree
B.Tech

Dept. of Electrical and Electronics Engineering
Kits WGL, Warangal (T.S), India

Abstract: This paper presents a method to operate a grid connected hybrid system. The hybrid system composed of a Photovoltaic (PV) array and a Proton exchange membrane fuel cell (PEMFC) is considered. Two operation modes, the unit-power control (UPC) mode and the feeder-flow control (FFC) mode, can be applied to the hybrid system. In the UPC mode, variations of load demand are compensated by the main grid because the hybrid source output is regulated to reference power. Renewable energy is currently widely used. One of these resources is solar energy. The photovoltaic (PV) array normally uses a maximum power point tracking (MPPT) technique to continuously deliver the highest power to the load when there are variations in irradiation and temperature. The disadvantage of PV energy is that the PV output power depends on weather conditions and cell temperature, making it an uncontrollable source. Furthermore, it is not available during the night. In order to overcome these inherent drawbacks, alternative sources, such as PEMFC, should be installed in the hybrid system. By changing the FC output power, the hybrid source output becomes controllable. Therefore, the reference value of the hybrid source output must be determined. In the FFC mode, the feeder flow is regulated to a constant, the extra load demand is picked up by the hybrid source, and, hence, the feeder reference power must be known. The system can maximize the generated power when load is heavy and minimizes the load shedding area. When load is light, the UPC mode is selected and, thus, the hybrid source works more stably. The changes in operating mode only occur when the load demand is at the boundary of mode change; otherwise, the operating mode is either UPC mode or FFC mode. Besides, the variation of hybrid source reference power is eliminated by means of hysteresis. The proposed operating strategy with a flexible operation mode change always operates the PV array at maximum output power and the PEMFC in its high

efficiency performance band, thus improving the performance of system operation, enhancing system stability, and decreasing the number of operating mode change.

Keywords- Distributed generation, fuel cell, hybrid system, micro grid, photovoltaic, Power management.

I. INTRODUCTION

Renewable energy is currently widely used. One of these resources is solar energy. The photovoltaic (PV) array normally uses a maximum power point tracking (MPPT) technique to continuously deliver the highest power to the load when there are variations in irradiation and temperature. The disadvantage of PV energy is that the PV output power depends on weather conditions and cell temperature, making it an uncontrollable source. Furthermore, it is not available during the night. In order to overcome these inherent drawbacks, alternative sources, such as PEMFC, should be installed in the hybrid system. By changing the FC output power, the hybrid source output becomes controllable. However, PEMFC, in its turn, works only at a high efficiency within a specific power range.

The hybrid system can either be connected to the main grid or work autonomously with respect to the grid-connected mode or islanded mode, respectively. In the grid-connected mode, the hybrid source is connected to the main grid at the point of common coupling (PCC) to deliver power to the load. When load demand changes, the power supplied by the main grid and hybrid system must be properly changed. The power delivered from the main grid and PV array as well as PEMFC must be coordinated to meet load demand. The hybrid source has two control modes: 1) unit-power control (UPC) mode and 2) feeder-flow control (FFC) mode. In the UPC mode, variations of load demand are compensated by the main grid because the hybrid source output is regulated to reference power. Therefore, the reference value of the hybrid source output must be determined. In the FFC

mode, the feeder flow is regulated to a constant, the extra load demand is picked up by the hybrid source, and, hence, the feeder reference power must be known. The proposed operating strategy is to coordinate the two control modes and determine the reference values of the UPC mode and FFC mode so that all constraints are satisfied. This operating strategy will minimize the number of operating mode changes, improve performance of the system operation, and enhance system stability.

II. SYSTEM DESCRIPTION

A. Structure of Grid-Connected Hybrid Power System

The system consists of a PV-FC hybrid source with the main grid connecting to loads at the PCC as shown in Fig. 1. The photovoltaic and the PEMFC are modeled as nonlinear voltage sources. These sources are connected to dc-dc converters which are coupled at the dc side of a dc/ac inverter. The dc/dc connected to the PV array works as an MPPT controller.

Many MPPT algorithms have been proposed in the literature, such as

1. incremental conductance (INC),
2. constant voltage (CV),
3. Perturbation and observation (P&O).

The P&O method has been widely used because of its simple feedback structure and fewer measured parameters. The P&O algorithm with power feedback control. As PV voltage and current are determined, the power is calculated. At the maximum power point, the derivative (dP/dV) is equal to zero. The maximum power point can be achieved by changing the reference voltage by the amount of ΔV_{ref} .

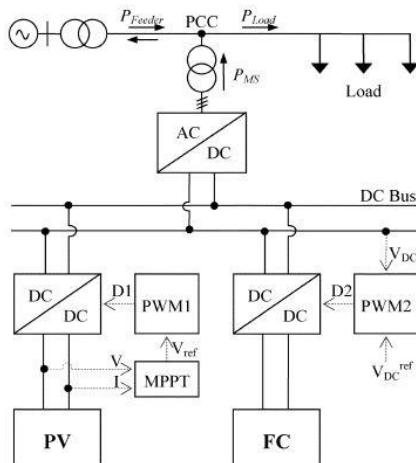

Figure 1: Grid-Connected PV-FC hybrid system.

B. PV Array Model

The mathematical model can be expressed as

$$I = I_{ph} - I_{sat} \{ \exp[q/AKT(V + IR_s)] - 1 \} \quad (1)$$

Equation (1) shows that the output

characteristic of a solar cell is nonlinear and vitally affected by solar radiation, temperature, and load condition. Photocurrent I_{ph} is directly proportional to solar radiation G_a .

$$I_{ph}(G_a) = I_{sc} \frac{G_a}{G_{as}} \quad (2)$$

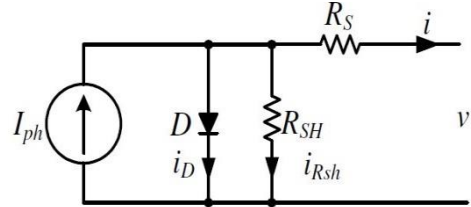

Figure 2: Equivalent representation of a PV panel

The short-circuit current of solar cell I_{sc} depends linearly on cell temperature

$$I_{sat}(T) = I_{scs} [1 + \Delta I_{sc}(T - T_s)] \quad (3)$$

Thus, I_{ph} depends on solar irradiance and cell temperature

$$I_{ph}(G_a, T) = I_{sc} \frac{G_a}{G_{as}} [1 + \Delta I_{sc}(T - T_s)] \quad (4)$$

I_{sat} also depends on solar irradiance and cell temperature and can be mathematically expressed as follows:

$$I_{sat}(G_a, T) = \frac{I_{ph}(G_a, T)}{e^{\frac{V_{oc}(T)}{V_t(T)} - 1}} \quad (5)$$

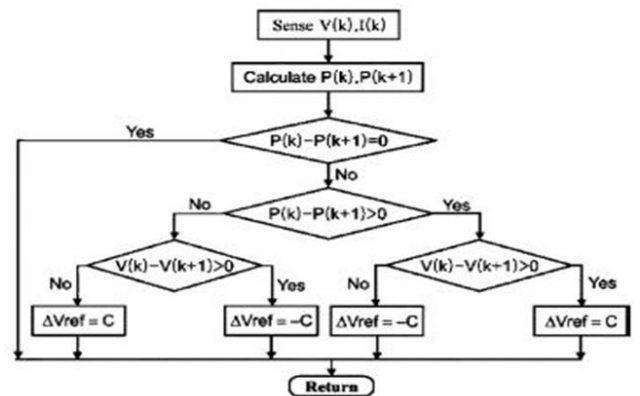

Figure 3: P & O algorithm

C. PEMFC Model

The PEMFC steady-state feature of a PEMFC source is assessed by means of a polarization curve, which shows the nonlinear relationship between the voltage and current density. The

PEMFC output voltage is as follows:

$$V_{out} = E_{Nerst} - V_{act} - V_{ohm} - V_{conc} \quad (6)$$

Where is the E_{Nerst} , 'thermodynamic potential' of Nernst, which represents the reversible (or open-circuit) voltage of the fuel cell?

Activation voltage drop V_{act} is given in the Table equation as

$$V_{act} = T[a + b \ln(I)] \quad (7)$$

Where are the constant terms in the Table equation (in volts per Kelvin)

The overall ohmic voltage drop V_{ohm} can be expressed as

$$V_{ohm} = IR_{ohm} \quad (8)$$

The ohmic resistance R_{ohm} of PEMFC consists of the resistance of the polymer membrane and electrodes, and the resistances of the electrodes.

The concentration voltage drop V_{conc} is expressed as:

$$V_{conc} = -\frac{RT}{zF} \ln\left(1 - \frac{I}{I_{limit}}\right) \quad (9)$$

D. MPPT Control

The INC method offers good performance under rapidly changing atmospheric conditions. However, four sensors are required to perform the computations. If the sensors require more conversion time, then the MPPT process will take longer to track the maximum power point. During tracking time, the PV output is less than its maximum power. This means that the longer the conversion time is, the larger amount of power loss will be. On the contrary, if the execution speed of the P&O method increases, then the system loss will decrease. Moreover, this method only requires two sensors, which results in a reduction of hardware requirements and cost. Therefore, the P&O method is used to control the MPPT process. Two different applied control methods that are often chosen are

1. voltage-feedback control
2. Power-feedback control.

Voltage-feedback control uses the solar-array terminal voltage to control and keep the array operating near its maximum power point by regulating the array's voltage and matching the voltage of the array to a desired voltage. The drawback of the voltage-feedback control is its neglect of the effect of irradiation and cell temperature. Therefore, the power-feedback control is used to achieve maximum power.

The P&O MPPT algorithm with a power-feedback control is shown. As PV voltage and current are determined, the power is calculated. At the maximum power point, the derivative is equal to zero. The maximum power point can be achieved by changing the reference voltage by the amount of ΔV_{ref} .

In order to implement the MPPT algorithm, a buck-boost dc/dc converter is used as depicted in Fig.4. The parameters L and C in the buck-boost converter must satisfy the following conditions:

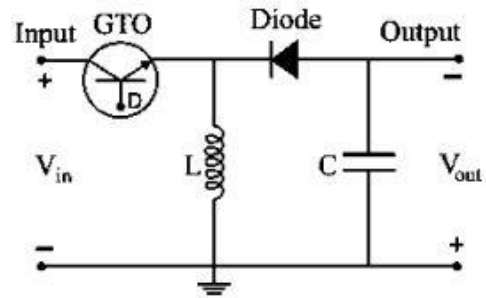

Figure 4: Buck-Boost topology

$$L > \frac{(1-D)^2 R}{2f} ; C > \frac{D}{Rf(\Delta V/V_{out})} \quad (10)$$

The buck-boost converter consists of one switching device (GTO) that enables it to turn on and off depending on the applied gate signal D. The gate signal for the GTO can be obtained by comparing the saw tooth waveform with the control voltage.

The change of the reference voltage ΔV_{ref} obtained by MPPT algorithm becomes the input of the pulse width modulation (PWM). The PWM generates a gate signal to control the buck-boost converter and, thus, maximum power is tracked and delivered to the ac side via a dc/ac inverter.

III. CONTROL OF THE HYBRID SYSTEM

The control modes in the micro grid include unit power control, feeder flow control, and mixed control mode. The two control modes were first proposed by Lasserter. In the UPC mode, the DGs (the hybrid source in this system) regulate the voltage magnitude at the connection point and the power that source is injecting. In this mode if a load increases anywhere in the micro grid, the extra power comes from the grid, since the hybrid source regulates to a constant power. In the FFC mode, the DGs regulate the voltage magnitude at the connection point and the power that is flowing in the feeder at connection point. With this control mode, extra load demands are picked up by the DGs, which maintain a constant load from the utility viewpoint.

In the mixed control mode, the same DG could control either its output power or the feeder flow power. In other words, the mixed control mode is a coordination of the UPC mode and the FFC mode. In this paper, a coordination of the UPC mode and the FFC mode was investigated to determine when each of the two control modes was applied and to determine a reference value for each mode. Moreover, in the hybrid system, the PV and PEMFC sources have their constraints. Therefore, the reference power must be set at an appropriate value so that the constraints of these sources are satisfied. This proposed operating strategy will be able to improve performance of the system's operation and enhance system stability.

IV. OPERATING STRATEGY OF THE HYBRID SYSTEM

As mentioned before, the purpose of the operating algorithm is to determine the control mode of the hybrid source and the reference value for each control mode so that the PV is able to work at maximum output power and the constraints (P_{FC}^{low} , P_{FC}^{up} and P_{FC}^{max})

Once the constraints are known, the control mode of the hybrid source (UPC mode and FFC mode) depends on load variations and the PV output. The control mode is decided by the algorithm shown in Fig. 8, Subsection B. In the UPC mode, the reference output power of the hybrid source depends on the PV output and the constraints of the FC output. The algorithm determining is presented in Subsection A and is depicted in Fig. 5

A. Operating Strategy for the Hybrid System in the UPC Mode

In this subsection, the presented algorithm determines the hybrid source works in the UPC mode. This algorithm allows the PV to work at its maximum power point, and the FC to work within its high efficiency band. In the UPC mode, the hybrid source P_{MS}^{ref} regulates the output to the reference value. Then

$$P_{pv} + P_{FC} = P_{MS}^{ref} \quad (11)$$

Equation (11) shows that the variations of the PV output will be compensated for by the FC power and, thus, the total power will be regulated to the reference value.

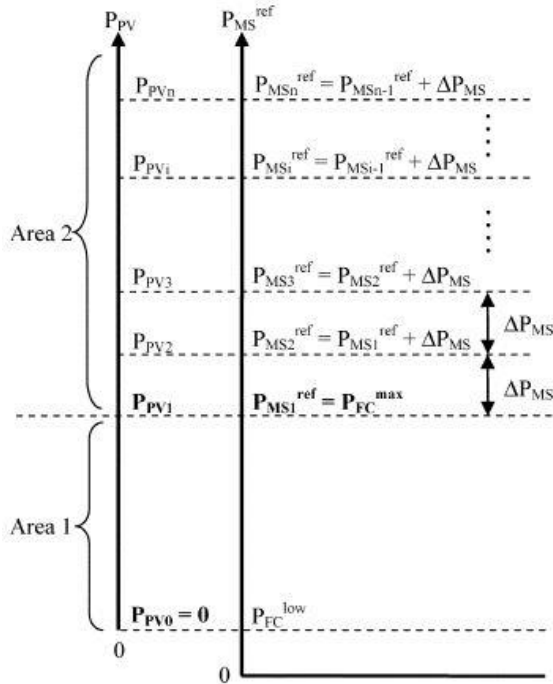

Figure 5: Operation Strategy of hybrid source in the UPC mode.

However, the FC output must satisfy its constraints and, hence, P_{MS}^{ref} must set at an appropriate value Fig. 5 shows the operation strategy of the hybrid source in UPC mode to determine P_{MS}^{ref} . The algorithm includes two areas: Area 1 and Area 2. In Area 1 P_{pv} is less than P_{pv1} , and then the reference Power P_{MS1}^{ref} is set at P_{FC}^{up} where

$$P_{pv1} = P_{FC}^{up} - P_{FC}^{low} \quad (12)$$

$$P_{MS1}^{ref} = P_{FC}^{up} \quad (13)$$

If PV output is zero, then (11) P_{FC} deduces to be equal to P_{FC}^{up} . If the PV output increases to P_{pv1} , then from (11) and (12), we obtain P_{FC} equal to P_{FC}^{low} . In other words, when the PV output varies from zero to P_{pv1} , the FC output will change from P_{FC}^{up} to P_{FC}^{low} . As a result, the constraints for the FC output always reach Area 1. It is noted that the reference power of the hybrid source during the UPC mode is fixed at a constant P_{FC}^{up} .

Area 2 is for the case in which PV output power is greater than P_{pv1} , as examined earlier, when the PV output increases to P_{pv1} , the FC output will decrease to its lower limit P_{FC}^{low} . If PV output keeps increasing, the FC output will decrease below its limit P_{FC}^{low} .

In this case, to operate the PV at its maximum power point and the FC within its limit, the reference power must be increased. As depicted in Fig. 5 if PV output is larger than P_{pv1} , the reference power will be increased by the amount of ΔP_{MS} , and we obtain

$$P_{MS2}^{ref} = P_{MS1}^{ref} + \Delta P_{MS} \quad (14)$$

Similarly, if P_{pv} is greater than P_{pv2} , the FC output becomes less than its lower limit and the reference power will be thus increased by the amount of ΔP_{MS} . In other words, the reference power remains unchanged and equal to P_{MS2}^{ref} if P_{pv} is less than P_{pv2} and greater than P_{pv1} , where

$$P_{pv2} = P_{pv1} + \Delta P_{MS} \quad (15)$$

It is noted that is limited so that with the new reference power, the FC output must be less than its upper limit. Then, we have

$$\Delta P_{MS} \leq P_{FC}^{up} - P_{FC}^{low} \quad (16)$$

In general, if the PV output is between P_{pvi} and P_{pvi-1} then we have

$$P_{MSi}^{ref} = P_{MSi-1}^{ref} + \Delta P_{MS} \quad (17)$$

$$P_{pvi} = P_{pvi-1} + \Delta P_{MS} \quad (18)$$

Equations (17) and (18) show the method of finding the reference power when the PV output is in Area 2. The relationship between P_{MSi}^{ref} and P_{pvi} is obtained by using (12), (13), and (18) in (17), and then

$$P_{MSi}^{ref} = P_{pvi} + P_{FC}^{min} \quad i=2,3,4,\dots \quad (19)$$

The determination of P_{MS}^{ref} in Area 1 and Area 2 can be generalized by starting the index from 1. Therefore, if the PV output is

$$P_{pvi-1} \leq P_{pv} \leq P_{pvi}, \quad i=1,2,3,\dots$$

then we have

$$P_{MSi}^{ref} = P_{pvi} + P_{FC}^{min} \quad i=2,3,4,\dots \quad (20)$$

$$P_{pvi} = P_{pvi-1} + \Delta P_{MS} \quad i=2,3,4,\dots \quad (21)$$

It is noted that when $i=1$, P_{pv1} is given in (12), and

$$P_{pvi-1} = P_{pv0} = 0, \quad (22)$$

In brief, the reference power of the hybrid source is determined according to the PV output power. If the PV output is in Area 1, the reference power will always be constant and set at P_{FC}^{up} . Otherwise, the reference value will be changed by the amount of ΔP_{MS} , according to the change of PV power.

The reference power of the hybrid source P_{MS}^{ref} in Area 1 and Area 2 is determined by (20) and (21). P_{pv0} , P_{pv1} , and ΔP_{MS} are shown in (22), (12), and (16), respectively. Fig. 5 shows the control algorithm diagram for determining the reference power automatically. The constant C must satisfy (16). If C increases the number of change of P_{MS}^{ref} will decrease and thus the performance of system operation will be improved. However, C should be small enough so that the frequency does not change over its limits (5%).

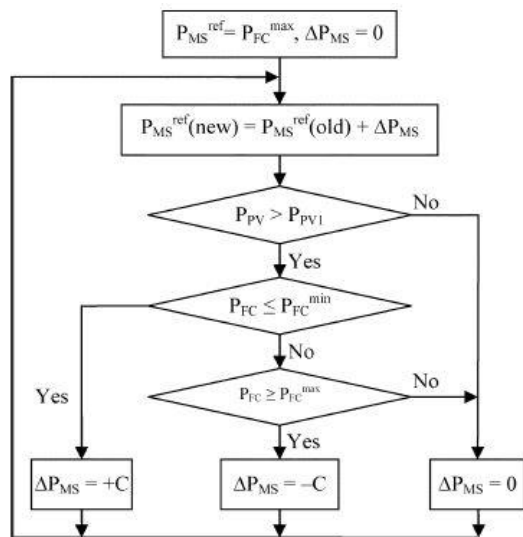

Figure 6: Control algorithm diagrams in the UPC mode (P_{MS}^{ref} automatically changing)

In order to improve the performance of the algorithm, a hysteresis is included in the simulation model. The hysteresis is used to prevent oscillation of the setting value of the hybrid system reference power P_{MS}^{ref} . At the boundary of change in P_{MS}^{ref} , the reference value will be changed continuously due to the oscillations in PV maximum power tracking. To avoid the oscillations around the

boundary, a hysteresis is included and its control scheme to control P_{MS}^{ref} is depicted in Fig. 7

B. Overall operating strategy for the grid-connected hybrid system

It is well known that in the micro grid, each DG as well as the hybrid source has two control modes: 1) the UPC mode and 2) the FFC mode. In the aforementioned subsection, a method to determine P_{MS}^{ref} in the UPC mode is proposed. In this subsection, an operating strategy is presented to coordinate the two control modes. The purpose of the algorithm is to decide when each control mode is applied and to determine the reference value of the feeder flow when the FFC mode is used. This operating strategy must enable the PV to work at its maximum power point, FC output, and feeder flow to satisfy their constraints.

If the hybrid source works in the UPC mode, the hybrid output is regulated to a reference value and the variations in load are matched by feeder power.

With the reference power P_{MS}^{ref} proposed in Subsection A, the constraints of FC and PV are always satisfied. Therefore, only the constraint of feeder flow is considered. On the other hand, when the hybrid works in the FFC mode, the feeder flow is controlled to a reference value P_{feeder}^{ref} and, thus, the hybrid source will compensate for the load variations. In this case, all constraints must be considered in the operating algorithm. Based on those analyses, the operating strategy of the system is proposed as demonstrated in Fig. 8

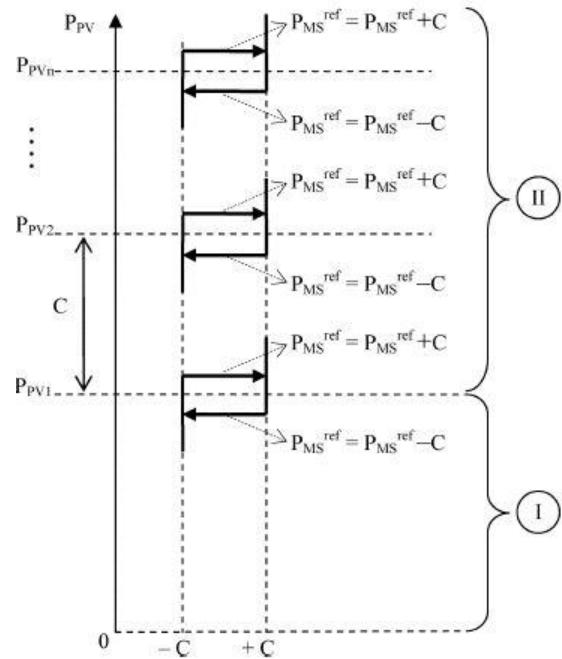

Figure 7: Hysteresis control scheme for P_{MS}^{ref} control

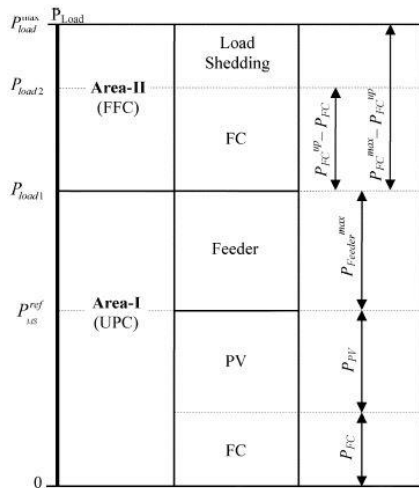

Figure 8: overall operating strategy of a grid connected Hybrid System

The operation algorithm in Fig. 8 involves two areas (Area I and Area II) and the control mode depends on the load power. If load is in Area I, the UPC mode is selected. Otherwise, the FFC mode is applied with respect to Area II.

In the UPC area, the hybrid source output is P_{MS}^{ref} . If the load is lower than P_{MS}^{ref} , the redundant power will be transmitted to the main grid. Otherwise, the main grid will send power to the load side to match load demand. When load increases, the feeder flow will increase correspondingly. If feeder flow increases to its maximum P_{feeder}^{max} , then the feeder flow cannot meet load demand if the load keeps increasing. In order to compensate for the load demand, the control mode must be changed to FFC with respect to Area II. Thus, the boundary between Area I and Area II P_{load1} is

$$P_{load1} = P_{MS}^{ref} + P_{feeder}^{max} \quad (23)$$

When the mode changes to FFC, the feeder flow reference must be determined. In order for the system operation to be seamless, the feeder flow should be unchanged during control mode transition. Accordingly, when the feeder flow reference is set at P_{feeder}^{max} , then we have

$$P_{feeder}^{ref} = P_{feeder}^{max} \quad (24)$$

In the FFC area, the variation in load is matched by the hybrid source. In other words, the changes in load and PV output are compensated for by PEMFC power. If the FC output increases to its upper limit and the load is higher than the total generating power, then load shedding will occur. The limit that load shedding will be reached is

$$P_{load2} = P_{FC}^{up} + P_{feeder}^{max} + P_{pv} \quad (25)$$

Equation (25) shows that P_{load2} is minimal when PV output is at 0 kW. Then

$$P_{load2}^{min} = P_{FC}^{up} + P_{feeder}^{max} \quad (26)$$

Equation (26) means that if load demand is less than P_{load2}^{min} , load shedding will never occur. From

the beginning, FC has always worked in the high efficiency band and FC output has been less than P_{FC}^{up} . If the load is less than P_{load2}^{min} , load shedding is ensured not to occur. However, in severe conditions, FC should mobilize its availability, P_{FC}^{max} to supply the load. Thus, the load can be higher and the largest load is

$$P_{load}^{max} = P_{FC}^{max} + P_{feeder}^{max} \quad (27)$$

If FC power and load demand satisfy (27), load shedding will never occur. Accordingly, based on load forecast, the installed power of FC can be determined by following (27) to avoid load shedding. Corresponding to the FC installed power, the width of Area II is calculated as follows:

$$P_{AreaII} = P_{FC}^{max} - P_{FC}^{up} \quad (28)$$

In order for the system to work more stably, the number of mode changes should be decreased. As seen in Fig.3.7, the limit changing the mode from UPC to FFC is P_{load1} , which is calculated in (23). Equation (24) shows that P_{load1} depends on P_{feeder}^{max} and P_{MS}^{ref} . P_{feeder}^{max} is a constant, thus P_{load1} depends on P_{MS}^{ref} .

TABLE 1
System Parameters

| PARAMETERS | VALUE | UNIT |
|--------------------|-------|------|
| P_{FC}^{low} | 0.01 | MW |
| P_{FC}^{up} | 0.07 | MW |
| P_{feeder}^{max} | 0.01 | MW |
| ΔP_{MS} | 0.03 | MW |

Fig. 5 shows that in Area 2 P_{MS}^{ref} depends on of ΔP_{MS} . Therefore, to decrease the number of mode changes, P_{MS}^{ref} changes must be reduced. Thus, ΔP_{MS} must be increased.

However ΔP_{MS} must satisfy condition (16) and, thus, the minimized number of mode change is reached when ΔP_{MS} is maximized.

$$\Delta P_{MS}^{max} = P_{FC}^{up} - P_{FC}^{low} \quad (29)$$

Mat lab based Simulink model

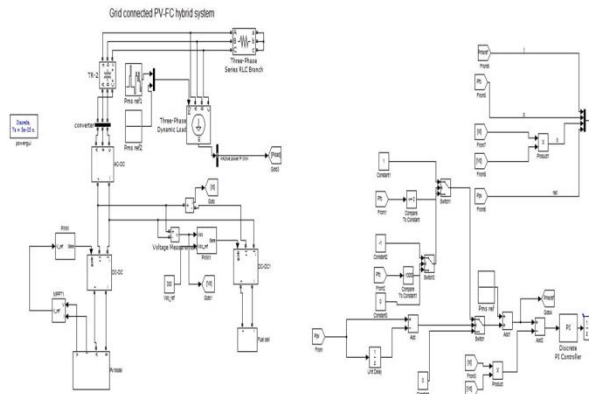

Figure 9: operating strategy of the hybrid system without hysteresis

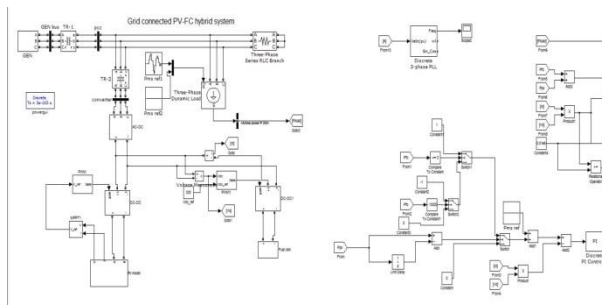

Figure 10: operating strategy of the whole system without hysteresis

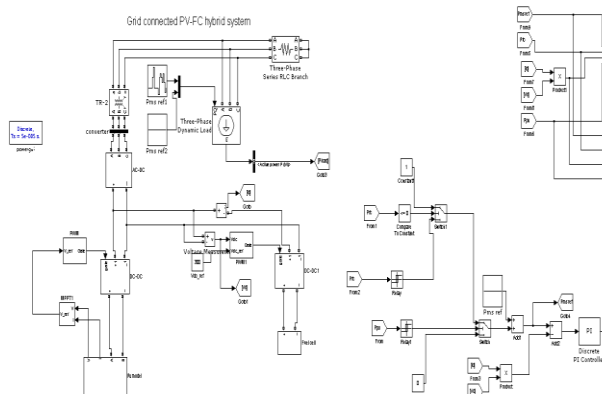

Figure 11: operating strategy of the hybrid system using hysteresis

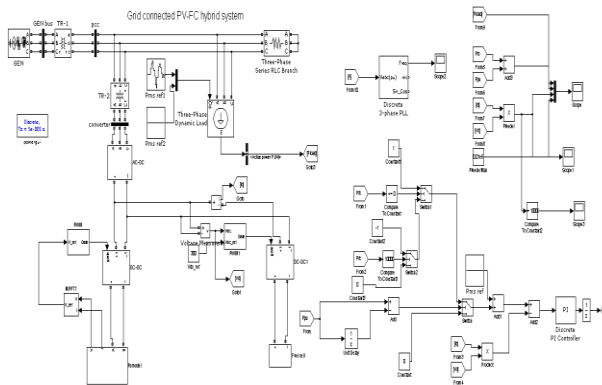
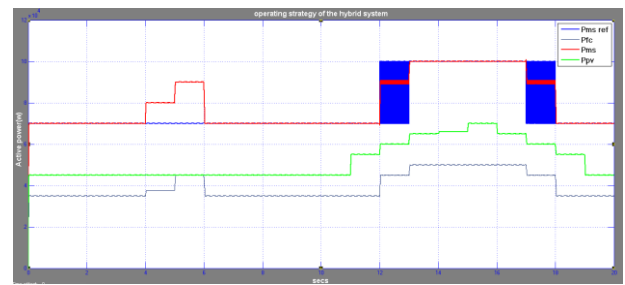
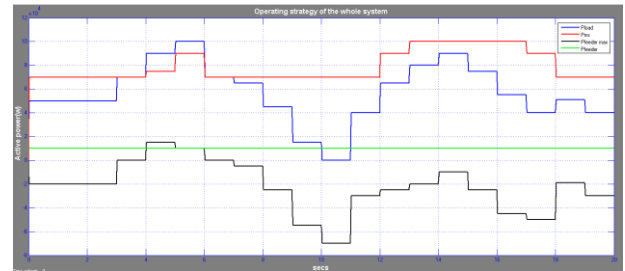

Figure 12: operating strategy of the whole system using hysteresis

Simulation results without hysteresis



(a)



(b)

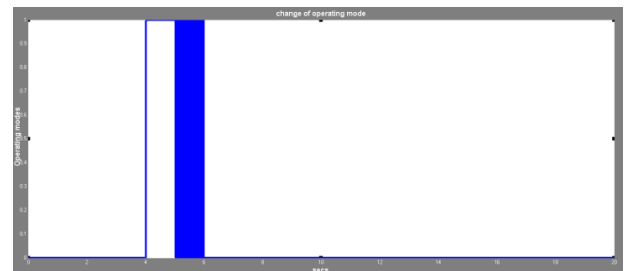

(c)

Figure 13: simulation result without hysteresis Controller (a) Operating strategy of the hybrid system (b) Operating strategy of the whole system (c) Change of operating modes.

Improving operating performance by using hysteresis

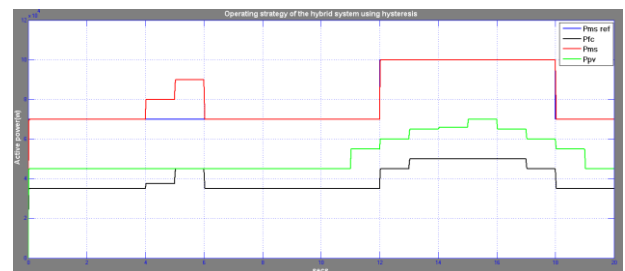

(a)

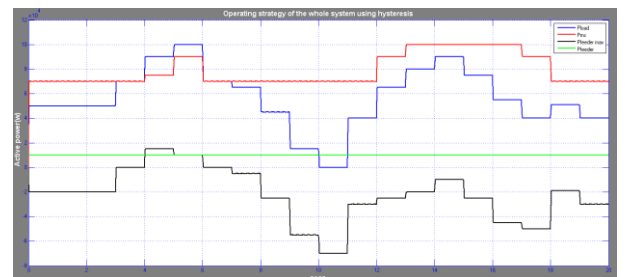

(b)

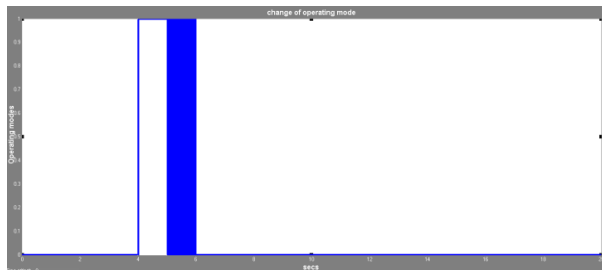

(c)

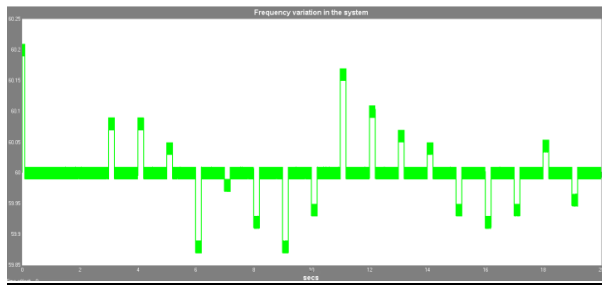

(d)

Figure 14: simulation result using hysteresis Controller (a) Operating strategy of the hybrid system (b) Operating strategy of the whole system (c) Change of operating modes (d) Frequency variation occur in the system

V. CONCLUSION

The hybrid system, composed of a PV array and PEMFC, was considered. The operating strategy of the system is based on the UPC mode and FFC mode. The purpose of the proposed operating strategy to determine the control mode, and to minimize the number of mode changes, to operate PV at the maximum power point, and to operate the FC output in its high-efficiency performance band. PV always operates at maximum output power, PEMFC operates with in the high-efficiency range ($(P_{FC}^{low} \div P_{FC}^{up})$), and feeder power flow is always less than its maximum value (P_{feeder}^{max}). The change of the operating mode depends on the current load demand, the PV output, and the constraints of PEMFC and feeder power.

The system works flexibly, exploiting maximum solar energy; PEMFC works with in a high-efficiency band and hence improves the performance of the systems operation. The system can maximize the generated power when load heavy and minimizes the load shedding area. When load is light the UPC mode is selected and thus the hybrid source works more stably.

The changes in operating mode only occur when the load demand is at the boundary of mode change (P_{load1}), otherwise the operating mode is either UPC mode or FFC mode. Besides, the variation of hybrid source reference power P_{MS}^{ref} is eliminated by means of hysteresis. The number of mode

changes is reduced. As a consequence, the system works more stably due to the minimization of mode changes and reference value variation.

VI. REFERENCES

- [1] W. Xiao, W. Dunford, and AAA. Capel, "A novel modeling method for photovoltaic cells," in *Proc. IEEE 35th Annu. Power Electronics Specialists conf.*, jun. 2004, vol. 3, pp. 1950-1956.
- [2] D. Sera, R. Teodorescu, and P. Rodriguez, "PV panel model based on datasheet values," in *Proc. IEEE Int. Symp. Industrial Electronics*, Jun. 4-7, 2007, pp. 2392-2396.
- [3] C. Hua and C. Shen, "Comparative study of peak power tracking techniques for solar storage system," in *Proc. 13th Annu. Applied Power Electronics Conf. Expo.*, Feb. 1998, vol. 2, pp. 679-685.
- [4] C. Hua and J. R. Lin, "DSP-based controller application in battery storage of photovoltaic system," in *Proc. 22nd IEEE Int. Conf. Industrial Electronics, Control, and Instrumentation*, Aug. 5-10, 1996, vol. 3, pp. 1750-1810.
- [5] R. H. Lasseter, "Microgrids," in *Proc. IEEE Power Eng. Soc. Winter Meeting*, Jan. 2002, vol. 1, pp. 305-308.
- [6] P. Piagi and R. H. Lasseter, "Autonomous control of micro grids," presented at the Power IEEE Eng. Soc. General Meeting, Montreal, QC, Canada, 2006.
- [7] R. H. Lasseter and P. Piagi, "Control and design of microgrid components," Jan. 2006, PSERC final project reports.
- [8] M. Barnes, G. Ventakaramanan, J. Kondoh, R. Lasseter, H. Asano, N. Hatzigiorgiou, J. Oyarzabal, and T. Green, "Real-world microgrids—An overview," in *Proc. IEEE Int. Conf. System of Systems Engineering*, Apr. 16-18, 2007, pp. 1-8.

IJEAST

INTERNATIONAL JOURNAL
OF ENGINEERING APPLIED SCIENCE
AND TECHNOLOGY

ABOUT IJEAST

International Journal of Engineering Applied Science and Technology (IJEAST) is a peer-reviewed, open access journal that publishes high-quality research papers in the field of Engineering, Applied Science and Technology.

IJEAST aims to provide a platform for researchers, academicians, and professionals to share their innovative ideas, research findings, and practical experiences with the global scientific community.

FOCUS AREAS

- Engineering
- Applied Science
- Technology
- Innovation & Development
- Interdisciplinary Studies



PEER REVIEWED

All submissions are rigorously peer reviewed to ensure quality.



OPEN ACCESS

Free and unrestricted access to research for all.



GLOBAL REACH

Connecting researchers and professionals worldwide.



TIMELY PUBLICATION

We ensure a swift and efficient publication process.



For more information, visit our website

www.ijeast.com



INTERNATIONAL JOURNAL
OF ENGINEERING APPLIED SCIENCE
AND TECHNOLOGY

✉ editor@ijeast.com

🌐 www.ijeast.com

📍 India



2455-2143