



IJEAST

INTERNATIONAL JOURNAL
OF ENGINEERING APPLIED SCIENCE
AND TECHNOLOGY



VOLUME : 6 ISSUE : 8 Print / Issue Publication Date: 14-Mar-2022



ISSN : 2455-2143



DOI : 10.33564/IJEAST.2021.v06i08.026

Indexed In



WWW.IJEAST.COM

editor@ijeast.com



“FUZZY LOGIC TO IMPROVE RELIABILITY INDICES AND VOLTAGE INSTABILITY CONSTRAINTS FOR CONTINGENCY ANALYSIS AND OPTIMAL POWER FLOW WITH RENEWABLE ENERGY SOURCES”

Mr.Siddappaji.M.R

Asst. Professor

Department of Electrical & Electronics Engineering
Sir.MVIT, Bengaluru, Karnataka India

Dr.K.Thippeswamy

Sel.Grade Lecturer

Department of Electrical & Electronics Engineering
S.J.Govt. Polytechnic, Bengaluru, Karnataka India

Synopsis:-Its survey's aim is to learn more about raising awareness about reliability indices in a distribution framework while using the predicates of optimum power flow approaches. The voltage unpredictability is evaluated by using an L-index, a VCPI-Centroid, and a triangle membership function to illustrate the compared input limits vulnerability as fuzzy sets. The method's practicality is facilitated by the results, which include a fuzzy burden stream for basic and critical scenarios without and with DG units. The suggested approach will be extremely useful in assuring the power grid's overall voltage security by estimating the probability of voltage breakdown under current load circumstances. This will assist in estimating the framework's maximum load capacity without causing voltage instability. A software tool is used to evaluate the method's effectiveness on an example IEEE 14-bus framework.

Keyword: - VCPI, DG, FL, VSC-OPF.

I. THE INTRODUCTION

In the current mass power system, voltage insecurity would result in a power outage. In an ideal power framework, the voltage should be controlled within acceptable limits to ensure a high level of customer service which is a serious issue in the power system's design and operation. As voltage falls to a sharp value, power flow from the stack to the source is reduced. This phenomenon is referred to as "voltage insecurity" [1]. Before voltage insecurity, both the bus angle and frequency remained constant, but fluctuations

in reactive power are also increasing in the power transmission system to the stage where it is difficult to maintain up with the voltage magnitude inside the cutoff. As a result, voltage insecurity happens as a consequence of the framework's inability to deliver reactive power to the load. It might also be caused by network distribution issues, a transformer failure, or the failure of a vital transmission line or generator, a line problem or bus fault, or a heavy HVDC power stream with insufficient shunt capacitance and inverters [20]. The OPF in the power framework is a problem of optimization under various restrictions. It is essentially a large and well-studied area of restricted optimization. The use of load flow equations in the layout of uniformity restrictions is an important feature of OPF. For minimizing scalar optimization tasks, OPF heavily depends on static optimization techniques. In 1968, Dommel and Tinney [12] proposed OPF for the purpose of minimization, in which the main request angle computation is based on correspondence and disparity constraints. OPF was utilized by Morrison et al. [3] to draw attention to the issues with the unregulated electricity grid. In addition, OPF has been used by researchers to address problems with the vertical electric grid. Normally controlling equipment, such as tap changing transformers, are used to overcome the aforementioned difficulties. In any case, they are not executed in a reasonable timeframe to prevent voltage breakdown. The majority of the proposed indices are based on a framework or on bus orientation. There hasn't been a lot of research on employing a line-based voltage steadiness list to evaluate voltage stability. The voltage strength index is used in this way to determine which lines are critical for a given load

scenario, allowing the system to be evaluated before line blackout.

II. SOURCE OF POWER FOR RENEWABLE ENERGY SYSTEM

2.1. Distributed Production

In 2005, Harrison and Wallace [10] set out the government's goals and justifications for raising the distribution generation linkage limit for distribution networks. In 2011, Amanita and Hamadan Goshen [4] proposed the PSO computation to find the optimal placement of distribution networks, areas and sizes of DGs Reduce the framework's total cost, power loss, and the number of DGs necessary. In 2012, Pushier et al. [5] proposed a financial/natural dispatching (EED) issue elaboration for a hybrid energy storage system that includes heat-producing units, sunlight-based, wind, and long-term storage. The inquiry is completed using a MATLAB simulation for a solar-powered setting with a lot of light. In 2014, Nick et al. [17] demonstrated a multi-objective streamlining issue to discover the best balance between specialized and economic objectives to determine in active distribution networks, the best allocation of distributed storage systems (DSSs). Ma et al. [11] provided a techno-economic study of a solar wind pumped storage system for an isolated micro-hybrid grid in 2015. Sichilalu et al. [6] developed an Open Circuit model of a heat pump water heater (HPWH) that is powered by a breeze generator-photovoltaic network design in 2017. Energy cost minimization is used to determine real capacity, which takes into consideration the hour of power duty.

2.2 Micro-grids

Sanseverino et al. [3] suggested an execution monitoring and deplaning technique in 2011 to handle the optimum generation dispatch problem in a smart grid by reducing fossil fuel byproducts and production costs while improving quality. In 2012, Battistelli et al. [15] offered a streamlining apparatus for energy executives operating within modest energy frameworks that were fused with V2G frameworks. In 2015, Riva Sanseverino et al. developed a new OPF approach for micro-grid MG. The approach yields the fewest mistakes and a stable working point with considerable droop parameters, which are utilized for essential voltage and recurrence guideline calculations.

2.3. Solar

Lin et al. [8] employed a working power limit system in 2012 to reduce PV power injection during top sunlight-based illumination in order to avoid voltage infringement. Martin [18] revealed the idea of a focused sun-based plant that relies on a regenerative Ranking cycle in 2015. Furthermore, quantitative modeling strategies are used to boost dry cooling innovations.

2.4. Wind

In 2016, Sedgwick et al. [13] proposed an approach for describing appropriate battery area, limit, and power rating while restricting the expense work under the particular imperatives. The goal function includes monetary components, investment, operation, and reliability expenses are part of the technical penalty element.

III. RADIAL DISTRIBUTED NETWORK FOLLOWED BY DIFFERENT STEPS.

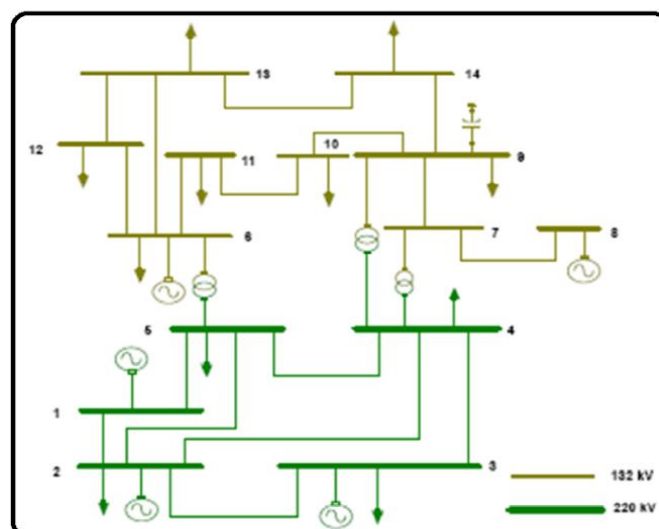

Fig.1:Sample Test system for 14-Bus IEEE



Algorithm

The Evaluated Reliability Index, OPF, Load Flow Analysis Fuzzy Logic algorithm is comprised of six basic steps. These would be respective names:

- 1] Perform a load flow study using contingency scenarios without DG to estimate reliability indices, voltage profile, VSC-OPF, and line loss.
- 2] Accurately predicts DG allocation and size in varied bus sites and demand.
- 3] Perform the load flow study again using Fuzzy Logic with DG to evaluate reliability indices, voltage profiles, VSC-OPF, and line loss..
- 4] A results will be compared with and without the need for energy sources.
- 5] Using the Mi-Power software, assess the performance of features and whether a long-term voltage instability scenario can be controlled with DG units.
- 6] Enhance overall voltage stability indices to help in the detection for voltage collapse.

IV. FUZZY INFERENCE SYSTEM

Along with a load bus value, a voltage index value with a value of 1 and a value of 0 were automatically normalized into a [0, 1] domain. Voltage profiles (VP), OPF-(P-Q), and Voltage instability constraints (VSC) are contributions to the fuzzy framework that utilize fuzzy inference to evaluate the seriousness lists of voltage profiles. In fuzzy logic-based systems, the information entry and exit variables are connected via if-then statements. A severity index of voltage profile(SI_{VP})& a voltage instability constraint (SI_{VSC})are assessed using a range of multiple-antecedent fuzzy rules, the contribution to the standards VP and VSC. The principles are represented in the table's fuzzy decision framework. Upon attaching the information factors to the outcome variable, the fuzzy outcomes are de-fuzzified using a Defuzzyficationinteraction to achieve an exact a number value. The centroid or Centre of gravity Defuzzyfication method was utilized. The fuzziness toolbox in MATLAB R2014a is used to analyze the fuzzy inference structure. With and without DG units, we validate the location obtained by the fuzzy technique.

4.1 VSC (Selected Fuzzy Input & Output) &Network Voltage Level: -

According to the triangle membership function, low voltage (LV) is less than 0.9 pu, normal voltage (NV) is 0.9-1.02 pu, and over voltage (OV) is greater than 1.02 pu. Using fuzzy set notation, triangular membership functions, which are

widely used to characterize the severity of a post-unexpected quantity, are divided into three categories: Below Sever (BS), Above Sever (AS), and Most Sever (MS). The Overall Severity Index is calculated when OSI_{VP} has identified the severity indices for all voltage profiles &OSI_{VSC}has identified the severity indices for all voltage instability constraints is computed as follows for a single-line blackout:

$$OSI_{VP} = \sum W SI \text{ ----- (1)}$$

$$OSI_{VSC} = \sum W SI \text{ ----- (2)}$$

$$CI = \sum W * SI_{VP} + \sum W * SI_{VSC}$$

The composite index (CI) combines both indices by taking into consideration that weighting coefficient used during severity indices, which seem to be severity index (SI) of the post-dependent quantity values is denoted by this variable. For BS = 0.30, AS = 0.60, and MS = 1.00, the weighting coefficients are BS = 0.30, AS = 0.60, and MS = 1.00. Due to the evident influence of these weighting variables, the three divisions of the severity index (MS) dominate the overall Severity Index, the second and first categories of the severity index; classify the system's vulnerabilities as fair severity.

4.2. Fuzzy Base Rules

Lists the severe indexes for bus voltage profiles and VSC indexes using fuzzy rules as shown in below

Table 1: Fuzzy Base Rules

INPUT VARIABLE	OUTPUT VARIABLE
VP	SI _{VP}
LV NV OV	BS AS MS
VSC	SI _{VSC}
LV NV OV	BS AS MS

4.3. Composite Index

As illustrated in Fig. 2, the general seriousness record CI = SI_{VP} + SI_{VSC} is the composite index for a particular section blackout. SI_{VP} indexes all load bus voltage profiles, while SI_{VSC} is the severity index of all voltage instability constraints in Optimal Power Flow (P and Q limits), L-index, and VCPI for choose possibilities. As a result, the final severity index for a particular scenario indicates the true severity of the framework.

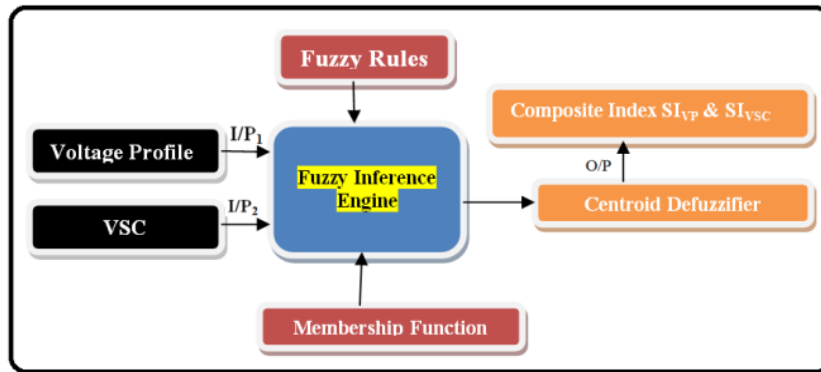

Fig.2: Shows the parallel fuzzy output.

V. OUTCOMES AND DISCUSSION

The IEEE 14-bus system is used to test fuzzy logic on line failures (outages) in Table 2, which lists outages assessed for ranking.

Table 2: A list of the contingencies failure cases that have been selected.

CASES	TYPE OF FAILURES	BETWEEN LINES	2	4
I	Single failure	line	2	4
II	Single failure	line	10	11
III	Double failure	line	2	4
			10	11

A. FUZZY LOGIC CONTINGENCY ANALYSIS FOR DIFFERENT CASES

5.1. Analysis of Contingency Cases

Table 3 shows the severity indices for voltage profiles generated using Fuzzy Logic without the use of DG.

Table 3: Voltage Profiles (VP) index for severity indices employing Fuzzy Logic without DG in different cases.

CASE-1: ***** BUS VOLTAGES *****													
NODE		FROM	VOLTAGE MAGNITUDE (P.U)				NODE		FROM	VOLTAGE MAGNITUDE (P.U)			
NO.	NAME	BASE CASE	OFF-P-1&2	OFF-P-3	OFF-Q	NO.	NAME	BASE CASE	OFF-P-1&2	OFF-P-3	OFF-Q		
1	BUS 1	1.06	1.06	1.06	1.06	1	BUS 1	58	58	57.8	57.7		
2	BUS 2	1.045	1.045	1.045	1.0378	2	BUS 2	58.3	58.3	58.1	58.1		
3	BUS 3	1.01	1.01	1.01	0.9924	3	BUS 3	58.7	58.7	58.6	58.7		
4	BUS 4	1.0006	1.0007	0.9935	0.9644	4	BUS 4	58.8	58.8	58.8	59		
5	BUS 5	1.0099	1.01	1.0036	0.9795	5	BUS 5	58.7	58.7	58.7	58.9		
6	BUS 6	1.0223	1.0223	1.0089	0.9838	6	BUS 6	58.6	58.6	58.6	58.8		
7	BUS 7	1.0391	1.0391	1.0264	0.9749	7	BUS 7	58.3	58.3	58.4	58.9		
8	BUS 8	1.0783	1.0783	1.066	1.0165	8	BUS 8	57.7	57.7	57.7	58.4		
9	BUS 9	1.0241	1.0241	1.0106	0.9553	9	BUS 9	58.6	58.6	58.6	59.1		
10	BUS 10	1.0163	1.0163	1.0027	0.9522	10	BUS 10	58.7	58.7	58.7	59.1		
11	BUS 11	1.0159	1.016	1.0024	0.964	11	BUS 11	58.7	58.7	58.7	59		
12	BUS 12	1.0078	1.0078	0.9934	0.9711	12	BUS 12	58.8	58.8	58.8	59		
13	BUS 13	1.0043	1.0044	0.9883	0.9675	13	BUS 13	58.8	58.8	58.9	59		
14	BUS 14	0.9968	0.9969	0.9739	0.9576	14	BUS 14	58.9	58.9	59	59.1		
								OSI _{VP}	760.8	760.8	819.4	822.8	
								ΣSI _{VP}	3163.8				



CASE-2: ***** BUS VOLTAGES *****														
NODE	FROM	VOLTAGE MAGNITUDE (P.U)				NODE	FROM	VOLTAGE MAGNITUDE (P.U)						
		NO.	NAME	BASE CASE	OPF-P-2			OPF-P-3	OPF-Q	NO.	NAME	BASE CASE	OPF-P-2	OPF-P-3
						FUZZY BASE RULES								
								SI_{VP}	SI_{VP}	SI_{VP}	SI_{VP}			
1	BUS 1	1.06	1.06	1.06	1.06	1	BUS 1	57.7	57.7	57.7	57.7			
2	BUS 2	1.045	1.045	1.045	1.0068	2	BUS 2	58	58	58	58.6			
3	BUS 3	1.01	1.01	1.01	0.9534	3	BUS 3	58.5	58.5	58.5	59.1			
4	BUS 4	1.0141	1.0141	1.0093	0.9202	4	BUS 4	58.5	58.5	58.5	59.3			
5	BUS 5	1.0204	1.0204	1.0159	0.9377	5	BUS 5	58.4	58.4	58.4	59.2			
6	BUS 6	0.991	0.991	0.9795	0.7735	6	BUS 6	58.8	58.8	58.9	59.5			
7	BUS 7	0.9789	0.9789	0.9682	0.7313	7	BUS 7	58.9	58.9	59	59.5			
8	BUS 8	1.0203	1.0203	1.0101	0.7851	8	BUS 8	58.4	58.4	58.5	59.4			
9	BUS 9	0.9807	0.9807	0.9691	0.6976	9	BUS 9	58.9	58.9	59	59.4			
10	BUS 10	0.9727	0.9727	0.961	0.6867	10	BUS 10	59	59	59.1	59.4			
11	BUS 11	0.984	0.984	0.9723	0.7645	11	BUS 11	58.8	58.8	59	59.5			
12	BUS 12	0.9751	0.9751	0.9624	0.7408	12	BUS 12	58.9	58.9	59.1	59.5			
13	BUS 13	0.9708	0.9708	0.9565	0.722	13	BUS 13	59	59	59.1	59.5			
14	BUS 14	0.9569	0.9569	0.9354	0.653	14	BUS 14	59.1	59.1	59.3	59.2			
								OSI_{VP}	820.9	820.9	822.1	828.8		
								ΣSI_{VP}	3292.7					

CASE-3: ***** BUS VOLTAGES *****														
NODE	FROM	VOLTAGE MAGNITUDE (P.U)				NODE	FROM	VOLTAGE MAGNITUDE (P.U)						
		NO.	NAME	BASE CASE	OPF-P-2			OPF-P-3	OPF-Q	NO.	NAME	BASE CASE	OPF-P-2	OPF-P-3
						FUZZY BASE RULES								
								SI_{VP}	SI_{VP}	SI_{VP}	SI_{VP}			
1	BUS 1	1.06	1.06	1.06	1.06	1	BUS 1	58	58	57.8	57.7			
2	BUS 2	1.045	1.045	1.045	1.0384	2	BUS 2	58.3	58.3	58.1	58.1			
3	BUS 3	1.01	1.01	1.01	0.9936	3	BUS 3	58.7	58.7	58.6	58.7			
4	BUS 4	1.0007	1.0007	0.9935	0.9662	4	BUS 4	58.8	58.8	58.8	59			
5	BUS 5	1.0009	1.0099	1.0035	0.9814	5	BUS 5	58.8	58.7	58.7	58.9			
6	BUS 6	1.0219	1.0219	1.0086	0.9921	6	BUS 6	58.6	58.6	58.6	58.7			
7	BUS 7	1.0393	1.0394	1.0265	0.9775	7	BUS 7	58.4	58.3	58.4	58.9			
8	BUS 8	1.0786	1.0785	1.0662	1.019	8	BUS 8	57.7	57.7	57.7	58.4			
9	BUS 9	1.0244	1.0244	1.0108	0.9583	9	BUS 9	58.6	58.6	58.6	59.1			
10	BUS 10	1.0167	1.0167	1.003	0.9501	10	BUS 10	58.7	58.7	58.7	59.2			
11	BUS 11	1.0151	1.0151	1.0017	0.9851	11	BUS 11	58.7	58.7	58.7	58.8			
12	BUS 12	1.0074	1.0075	0.9931	0.9769	12	BUS 12	58.8	58.8	58.8	58.9			
13	BUS 13	1.004	1.0041	0.9881	0.9708	13	BUS 13	58.8	58.8	58.9	59			
14	BUS 14	0.9969	0.9969	0.9739	0.9544	14	BUS 14	58.9	58.9	59	59.1			
								OSI_{VP}	819.8	819.6	819.4	822.5		
								ΣSI_{VP}	3281.3					

Table 4: Voltage instability constraints (VSC) index severity indices employing Fuzzy Logic without DG in different cases.

CASE-1: *****VOLTAGE INSTABILITY ANALYSIS*****										
SL NO.	BUS NO.	VOLT-MAG	L-INDEX	VCPI-CENTROID	NODE	FROM	VOLTAGE MAGNITUDE (P.U)			
							VOLT-MAG	L-INDEX	VCPI-CENTROID	
					FUZZY BASE RULES					
							SI_{VSC}	SI_{VSC}	SI_{VSC}	
1	BUS 4	1.000625	0.0436	0.035625	1	BUS 4	58.4	57.8	59.5	
2	BUS 5	1.009907	0.030884	0.034622	2	BUS 5	58.2	59.4	59.5	
3	BUS 7	1.039075	0.045626	0.144733	3	BUS 7	57.7	58.2	59.5	
4	BUS 9	1.020491	0.076168	0.170134	4	BUS 9	58	59.2	59.4	
5	BUS 10	1.016286	0.072262	0.177212	5	BUS 10	58.1	59.4	59.3	
6	BUS 11	1.015904	0.041134	0.178234	6	BUS 11	58.1	58.1	59.3	
7	BUS 12	1.0078	0.026453	0.190703	7	BUS 12	58.2	59.5	58.7	
8	BUS 13	1.004325	0.035425	0.192082	8	BUS 13	58.3	59	58.6	
9	BUS 14	0.996811	0.086142	0.202372	9	BUS 14	58.4	57.7	57.7	
							OSI_{VSC}	523.4	528.3	531.5
							ΣSI_{VSC}	1583.2		



CASE-2: ***VOLTAGE INSTABILITY ANALYSIS***										
SL NO.	BUS NO.	VOLT-MAG	L-INDEX	VCPI-CENTROID	NODE	FROM	VOLTAGE MAGNITUDE (P.U)			
					NO.	NAME	VOLT-MAG	L-INDEX	VCPI-CENTROID	
					FUZZY BASE RULES					SI _{vsc}
1	BUS 4	1.014088	0.034967	0.015354	1	BUS 4	57.8	59.5	58.9	
2	BUS 5	1.020362	0.025314	0.043782	2	BUS 5	57.7	59.5	59.5	
3	BUS 7	0.97887	0.058717	0.13384	3	BUS 7	58.4	58.2	59.5	
4	BUS 9	1.020491	0.076168	0.170134	4	BUS 9	57.7	59.5	59.4	
5	BUS 10	0.972741	0.11129	0.165613	5	BUS 10	58.5	57.7	59.5	
6	BUS 11	0.983998	0.008956	0.176946	6	BUS 11	58.3	58.9	59.2	
7	BUS 12	0.975069	0.029466	0.189452	7	BUS 12	58.5	59.4	58.5	
8	BUS 13	0.970755	0.040521	0.190459	8	BUS 13	58.5	59.4	58.4	
9	BUS 14	0.956906	0.104613	0.198943	9	BUS 14	58.7	58.7	57.7	
							OSI _{vsc}	524.1	530.8	530.6
							ΣSI _{vsc}	1585.5		

CASE-3: ***VOLTAGE INSTABILITY ANALYSIS***										
SL NO.	BUS NO.	VOLT-MAG	L-INDEX	VCPI-CENTROID	NODE	FROM	VOLTAGE MAGNITUDE (P.U)			
					NO.	NAME	VOLT-MAG	L-INDEX	VCPI-CENTROID	
					FUZZY BASE RULES					SI _{vsc}
1	BUS 4	1.000669	0.047583	0.035436	1	BUS 4	58.4	58.7	59.5	
2	BUS 5	1.009884	0.033501	0.034676	2	BUS 5	58.2	59.5	59.5	
3	BUS 7	1.039299	0.058181	0.143965	3	BUS 7	57.7	58.4	59.5	
4	BUS 9	1.024337	0.098487	0.169209	4	BUS 9	58	59	59.4	
5	BUS 10	1.016685	0.107959	0.175826	5	BUS 10	58.1	57.7	59.3	
6	BUS 11	1.015031	0.00842	0.180603	6	BUS 11	58.1	58.9	59.2	
7	BUS 12	1.007406	0.027942	0.191865	7	BUS 12	58.3	59.4	58.6	
8	BUS 13	1.004018	0.038586	0.193084	8	BUS 13	58.3	59.4	58.5	
9	BUS 14	0.996816	0.100171	0.202254	9	BUS 14	58.4	58.8	57.7	
							OSI _{vsc}	523.5	529.8	531.2
							ΣSI _{vsc}	1584.5		

Tables 3–4 show all instances severity indexes for VP and VSC derived using fuzzy base rules, as well as all indices computed with the composite index (CI).

5.2. Contingency No.1 Analysis

$\Sigma SI_{VP} = 3163.8$
 $\Sigma SI_{VSC} = 1583.2$
 $CI = \Sigma SI_{VP} + \Sigma SI_{VSC} = 4747$

5.3. Contingency No.2 Analysis

$\Sigma SI_{VP} = 3292.7$
 $\Sigma SI_{VSC} = 1585.5$
 $CI = \Sigma SI_{VP} + \Sigma SI_{VSC} = 4878.2$

5.4. Contingency No.3 Analysis

$\Sigma SI_{VP} = 3281.3$
 $\Sigma SI_{VSC} = 1584.5$
 $CI = \Sigma SI_{VP} + \Sigma SI_{VSC} = 4865.8$



Table 5: The criteria for the contingency analysis and fuzzy logic rankings are analyzed.

Contingency No.	CS CI=VP+ VSC	Ran k	FL CI = ΣSI_{VP} + ΣSI_{VSC}	Ran k
1	64.14174	3	4747	3
2	67.62059	1	4878.2	1
3	67.51764	2	4865.8	2

LINE OUTAGE BETWEEN BUSES							
LINE OUTAGE		2-4		10-11		2-4 & 10-11	
DG UNITS		WODG	WDG	WODG	WDG	WODG	WDG
BUS VOLTAGE PROFILE	BS	0	0	0	0	0	0
	AS	0	0	0	0	0	0
	MS	6	6	6	6	6	6
VOLTAGE INSTABILITY CONSTRAINTS	BS	5	4	7	8	5	4
	AS	3	4	2	1	2	1
	MS	1	2	1	2	3	2

Table 6: The number of lines/buses in each severity level.

Ranking may be easily confirmed by looking at table 6, which provides the number of lines/buses in each severity class. Table 5 shows that the outage contingency number-2 without DG has a larger number of lines/buses in the MS severity category. As a consequence, it is rated first. As just a result, for contingency scenario second position on severity categories, optimal placement of DG based on allocations of size, location, & various sites is required. The proposed contingency ranking method is capable of clearly identifying the genuine severity of the system in terms of line loading and bus voltage profile from one scenario to the next. As a result, the proposed solution solves the masking effect issue.

Since the maximum rating is specified by the local distribution network design, it is not possible to specify the rating of sources that supply distributed generation (DG), for instance the load demand. However, DG grading subcategories must be introduced [3].

The classes are as follows:

- Its Distribution Generation (DG) ranges from 1 watt to 5 KW
- 5 KW–5 MW slight DG
- 5MW-50MW moderate DG
- A huge assortment of DG (50MW-300MW)

B. Opdg (Optimal Dg Placement) With Contingency Analysis For Distinct Case Studies Using Fuzzy Logic.

See Table-6 for a listing of additional effect categories (MS) on the IEEE 14-bus test system. Based on contingency scenarios and a fuzzy logic approach for Tables 4&5, the ideal placement of DG in Contingency No.2 for Table No.5 will be found. Improving voltage profile and reliability reduces line losses, improve the economic dispatch, but also reduces voltage instability dependency.

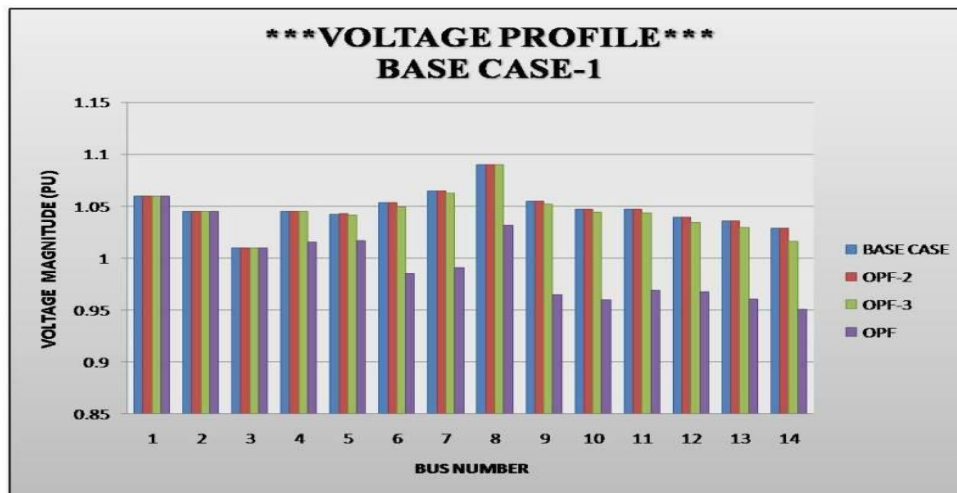

Fig.3: OPDG of Voltage Profile in the Post-contingency cases-1 using fuzzy logic with DG.

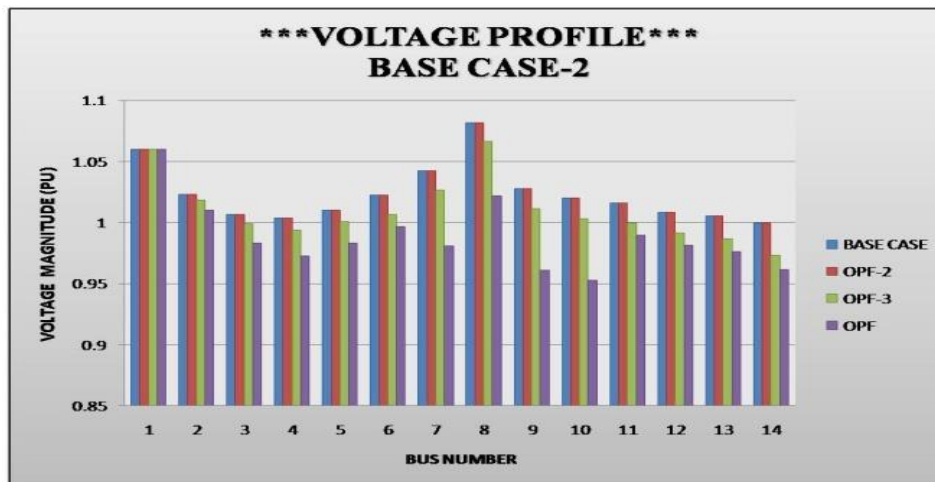

Fig.4: OPDG of Voltage Profile in the Post-contingency cases-2 using fuzzy logic with DG.

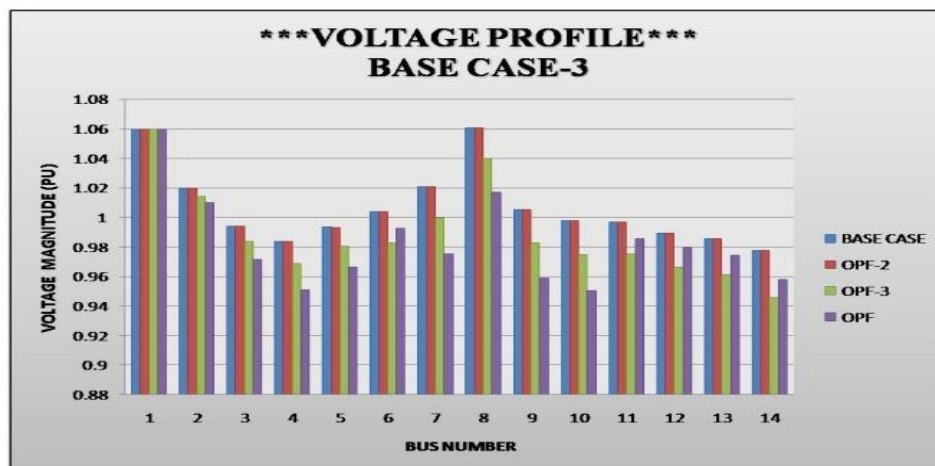

Fig.5: OPDG of Voltage Profile in the Post-contingency cases-3 using fuzzy logic with DG.

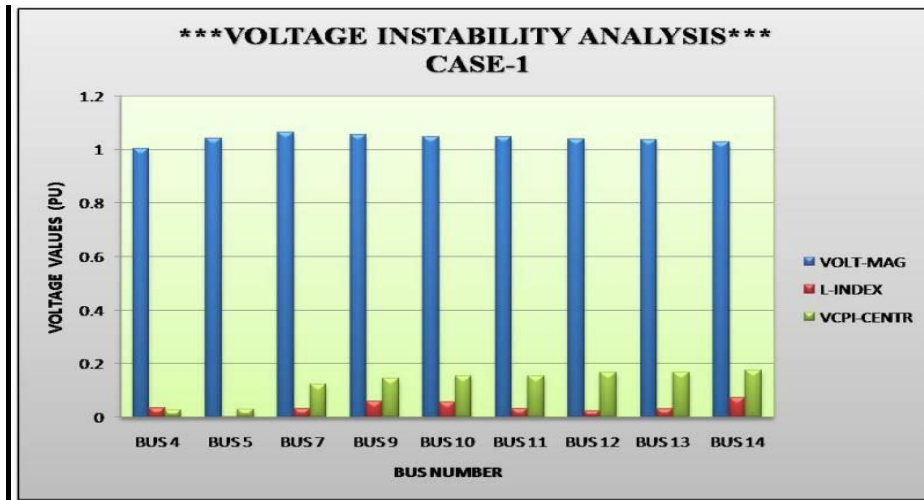

Fig.6: OPDG of Voltage Instability constraints in the Post-contingency cases-1 using fuzzy logic with DG.

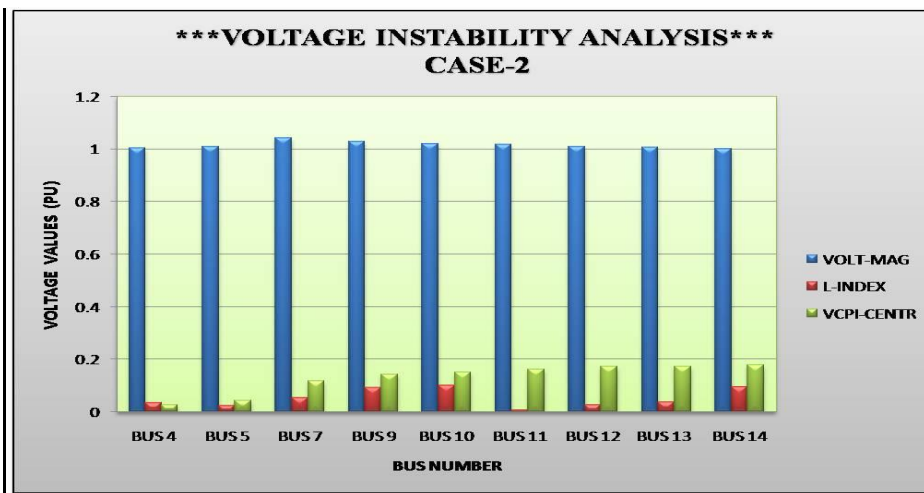

Fig.7: OPDG of Voltage Instability constraints in the Post-contingency cases-1 using fuzzy logic with DG.

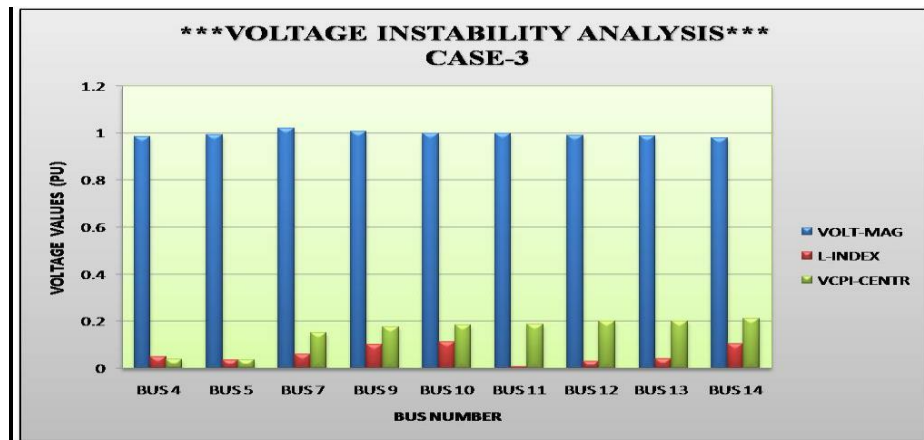

Fig.8: OPDG of Voltage Instability constraints in the Post-contingency cases-1 using fuzzy logic with DG.

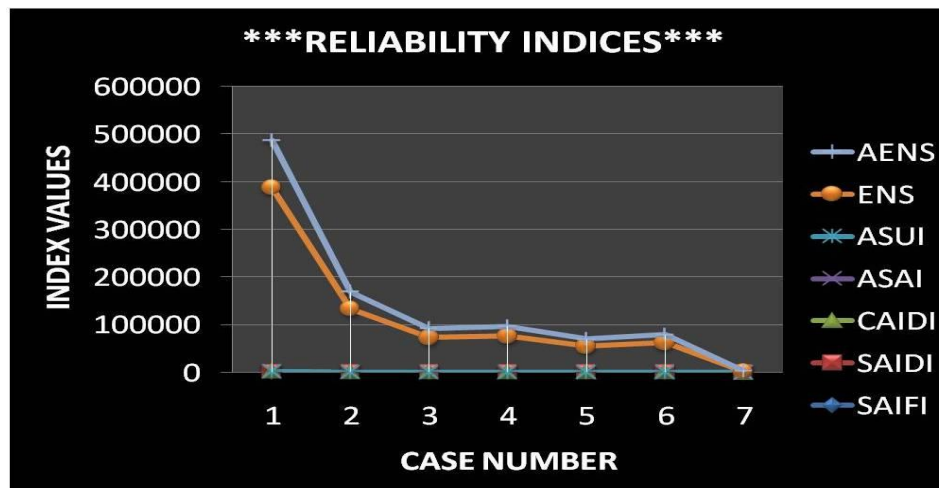

Fig.9: Considering constant OPDG of Reliability Indices in the different contingency cases using fuzzy logic with DG.

When comparing the effect of interruption on dependability with and without DG, ENS & AENS will have a greater influence on the system. The rest of the indices will be the same.

VI. CONCLUSION

This paper proposes an effective investigation of voltage unpredictability and dependability indices using Fuzzy Based Rules, which works well on power frameworks in all conditions. However, because of quantity consecutive emphases in the fuzzy logic load stream approach is greater, the suggested algorithm does not require factorization, re-factorization, or Jacobin matrix computation at each cycle, demonstrating the correctness of the algorithm suggested. This method will be tremendously valuable in assuring a power system's voltage security by predicting the likelihood of voltage fluctuations. breakdown under existing peak load and assisting us in measuring the optimum burden capacity of a particular system without causing voltage insecurity.

VII. ACKNOWLEDGEMENT

The researcher would like to express their thankfulness to Sir. Management MVIT's for their aid and encouragement in preparing this work. Dr.K.Thippeswamy, our advisor, deserves special thanks for his suggestions.

VIII. REFERENCE

[1]. Carson W. Taylor, Power Voltage Stability, McGraw – Hill Inc, 1993.
 [2]. I.J. McGrath and D.P. Kothari, Power System Engineering, Tata McGraw Hill, 1994.
 [3]. M. Treaty and S. Mishap, “Bacteria foraging-based solution to optimize both real power loss and voltage stability limit,” IEEE Trans. Power Systems, vol. 22, no.1, Feb. 2007, pp. 240-248.

[4]. Carolina M. Alfonzo, Luis C. P. ad Silva, Flavor G. M. Lima, and Seconding Soars, “MW and MVAR management on supply and demand side for meeting voltage stability margin criteria”, IEEE Trans. Power Systems, vol. 19, no. 3, Aug. 2004, pp. 1538-1545.
 [5]. Wei Yan, Juan Yu, David C. Yu, and Kale Bhatpara, “A new reactive power flow model in rectangular form and its solution by predictor-corrector primal-dual interior-point method”, IEEE Trans. Power Systems, vol. 21, no. 1, Feb. 2006, pp. 61-67.
 [6]. Saia Chakrabarti and Benjamin Jeyasurya, “An enhanced radial basis function network for voltage stability monitoring considering multiple contingencies”, Electric Power System Research, vol. 77, no. 7, 2007, pp. 780-787.
 [7]. Ivan Simon, Gregor Verbal, and Ferdinand Gubina, “Local voltage- stability index using Tellegen”stheorem”, IEEE Trans. Power Systems, vol. 21, no. 3, Aug. 2006, pp. 1267-1275.
 [8]. T. Esaka, Y. Karaoke, and T. Ohtaka, “Voltage stability preventive control uses a new voltage stability index”, in Proc. 2004 Power system Technology Conferences, pp. 344-349.
 [9]. Costas Tournas and Michael Karystianos, “Load tap changers in Emergency and Preventive voltage stability control”, IEEE Trans. Power Systems, vol. 19, no. 1, Feb. 2004, pp. 492-498.
 [10]. Luis A. Ll. Karate, Carlos A. Castro, Jose Luis Martinez Ramos, and Esther Romero Ramos, “Fast computation of voltage stability security margins using non-linear programming techniques”, IEEE Trans. Power Systems, vol. 21, no. 1, Feb. 2006 pp. 19-27.
 [11]. Antonio J. Conejos, Federico Milano, and Raquel Garcia-Bertrand, “Congestion management ensuring



- voltage stability”,IEEE Trans. Power Systems, vol. 21, no. 1, Feb.2006, pp. 357-364.
- [12]. Yasushi Koyama, Tetsuo Sasaki, Satoru Ihara, and Elizabeth R. Portico, “Voltage Collapse Scenario Search”, in Proc. 2002 IEEE Power System Technology Conf., pp. 344–348.
- [13]. S. C. Chou be, L. D. Aria, and N. Dater, “Voltage Collapse Prediction Based on Line Voltage Stability Index”, IE (India) Journal of Institution of Engineers, vol. 82, Sep. 2001, pp. 107-112.
- [14]. M. Suzuki, S. Wada, M. Sato, T. Asano, and Y. Kudos, “Newly developed voltage security monitoring system”,IEEE Trans. Power Systems, vol. 7, no. 3, Aug. 1992, pp. 965-972,.
- [15]. Artist Sode-Yome, Nada rajah Mithulananthan, and Kwan Y. Lee, “ A maximum loading margin method for static voltage stability in power systems”,IEEE Trans. Power Systems, vol. 21, no. 2, May 2006, pp. 965-972,.
- [16]. Artist Sode-Yome, Maharajah Mithulananthan, and Kwan Y. Lee, “Economic generation direction for power system static voltage stability”, in Proc. 2006 IEEE Power Engineering Society General Meeting, vol. 8, no. 22, pp. 1-7.
- [17]. M. Moghavvemi, M.O.Faruque, “Power System Security and voltage Collapse: a line based indicator for prediction”, Electrical Power and Energy Systems, vol. 21, 1991, pp. 455-461.
- [18]. S.C. Cohune, L.D. Aria, N.Datar, “Voltage Collapse Prediction Based on Line Voltage Stability Index”, Institution of Engineers (India) Journal – Electrical,, September 2001, pp.107-112.
- [19]. V.A. Venison, V.A.Stroev, V I Dabchick and V I Taros, “Estimation of Electrical Power System Steady State Stability in Load Flow Calculations”, IEEE Transactions on PAS , vole .94, pp.1034, 1975.
- [20]. Vlachoginnis, J.G., “Fuzzy logic application in load flow studies”, IEEE Proceedings Generation Transmission Distribution, vol.148, no.1, pp.34-39, 2001.
- [21]. Lo, K.L., Lin, Y.J., and Sew, W.H. “Fuzzy logic method for adjustment of variable parameters in load – flow calculation”, IEEE Proceedings Generation Transmission Distribution, vol.146, no.3, 1999, pp.276-282.

IJEAST

INTERNATIONAL JOURNAL
OF ENGINEERING APPLIED SCIENCE
AND TECHNOLOGY

ABOUT IJEAST

International Journal of Engineering Applied Science and Technology (IJEAST) is a peer-reviewed, open access journal that publishes high-quality research papers in the field of Engineering, Applied Science and Technology.

IJEAST aims to provide a platform for researchers, academicians, and professionals to share their innovative ideas, research findings, and practical experiences with the global scientific community.

FOCUS AREAS

- Engineering
- Applied Science
- Technology
- Innovation & Development
- Interdisciplinary Studies



PEER REVIEWED

All submissions are rigorously peer reviewed to ensure quality.



OPEN ACCESS

Free and unrestricted access to research for all.



GLOBAL REACH

Connecting researchers and professionals worldwide.



TIMELY PUBLICATION

We ensure a swift and efficient publication process.



For more information, visit our website

www.ijeast.com



INTERNATIONAL JOURNAL
OF ENGINEERING APPLIED SCIENCE
AND TECHNOLOGY

✉ editor@ijeast.com

🌐 www.ijeast.com

📍 India



2455-2143