



IJEAST

INTERNATIONAL JOURNAL
OF ENGINEERING APPLIED SCIENCE
AND TECHNOLOGY



VOLUME : 2 ISSUE : 4 Print / Issue Publication Date: 31-Mar-2017



ISSN : 2455-2143



Indexed In



WWW.IJEAST.COM

editor@ijeast.com

DESIGN OF FEED AND PUNCH MACHINE – A REVIEW

Er. Prabhjot Singh
Department of Mechanical Engg.
Gulzar Group of Institute, Ludhiana,
Punjab, India

Er. Iqbaljeet Singh Grewal
Department of Mechanical Engg.
Ludhiana Polytechnic College, Ludhiana,
Punjab, India

Abstract— The main difference between the other punching machine and Feed and Punch machine is, there is no ideal stroke in the feed and punch machine. In other punching machine the external feeding mechanisms is required to feed the work piece but in the feed and punching machine the feeding mechanism is run mechanically, the feeding mechanism is design in that way the feeding mechanism is not included the load external load on the machine. In the punching machines the different motor is required to run the feeding mechanism, but in the feed and punching machine only one motor is able to run the machine with feeding mechanism efficiently.

Keywords— **Punch, Oscillating Arm, Gears etc**

I. INTRODUCTION

A. Introduction to Feed and Punch Machine

Machine Tool that changes the size or shape of a piece of material, usually sheet metal, by applying force to a punch they strike on the sheet. The form and construction of the Punch determine the shape produced on the work piece. A punch press has two components: the punch, which is attached to the oscillating (0 to 180 degree) arm, and table. The sheet is feeded on the table. The punch shear the work piece, which is held in the table. Punch presses are usually driven by electric motors.

B. History of Punch Machines

Antique 1900 Iron Punch Press was the oldest punching press. This press is manually used by the workers. This press was unable to cut different - different sizes hole in sheet. For cutting the different - different sizes hole the different - different press are required in previous years. Press Now days the hydraulic punching press is used. The hydraulic punching machine is a type of machine press used to cut holes in material. It can be small and hold one simple die set, or be very large, CNC operated, with a multi-station turret and hold a much larger and complex die set. Most punch presses are large machines with either a 'C type frame or a 'portal' (bridge) type frame.



Fig. 1. The First Industrial Punching

The C type has the hydraulic ram at the top foremost part, whereas the portal frame is much akin to a complete circle with the ram being centered within the frame to stop frame deflection or distortion.

C. Components and Structure of Feed and Punch Machine

The basic components of feed and punch machine are:

- 4 Bar Link Mechanism
- Oscillating Arm
- Ratchet
- Compound Gear Train
- Punch
- Fixture

II. DESIGN OF COMONENTS

A. 4 Bar Link Mechanism

The four bar linkage is the simplest and often times, the most useful mechanism. As we mentioned before, a mechanism composed of rigid bodies and lower pairs is called a linkage. A linkage that has at least one fixed link is a mechanism. The following example of a four bar linkage:

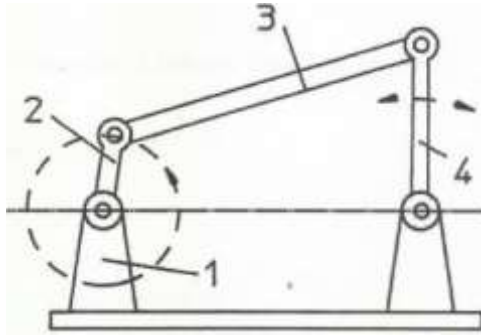

Fig. 2. Four Bar Linkage

This mechanism has three moving links. One is fixed link, is called frame. Grashof was a German Engineer in the late 1800s. Grashof's Law is used to determine the relative rotatability of the input and output links in a 4-bar mechanism:

- Crank - full rotation, no limits.

Rocker- not full rotation rotates back-and-forth between limits
 Mechanism types (input / output links): Identify longest, shortest, intermediate 2 links:

L, S, P, Q

1) If $L + S < P + Q$

Then we call this a Grashof Mechanism

2) If $L + S > P + Q$

Then we call this a Non-Grashof Mechanism and the four different mechanism inversions yield only one rotation condition:

3) If $L + S = P + Q$

Then we call this a Special Grashof Mechanism and the four different mechanism inversions yield the identical rotation conditions from eq.1 Grashof Mechanism. However, there is the additional interesting and troublesome feature that the mechanism may jump branches! Centrelines of links can become collinear.

Interactive Four-Bar Linkage Position Analysis

According to Grashof's theorem

- s = length of shortest bar
- l = length of longest bar
- p, q = lengths of intermediate bar

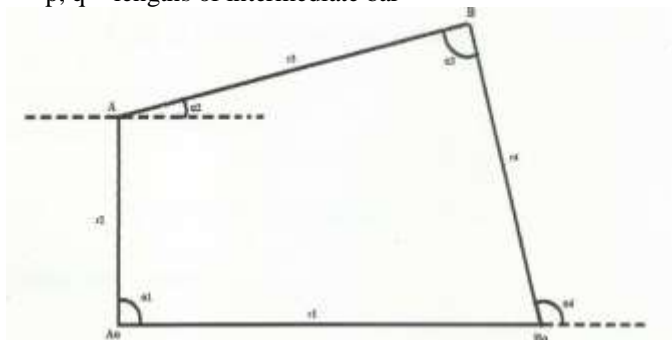

Fig. 3. Crank and Rocker Arm Mechanism

Grashof's theorem states that a four-bar mechanism has at least one revolving link if

$$s + l \leq p + q$$

$$r_1 = 90\text{mm}, r_2 = 40\text{mm}, r_3 = 82\text{mm}, r_4 = 80\text{mm}$$

$$40 + 90 < 82 + 80$$

Four bar Position Analysis

When $\theta_1 = 90$ degree

Angular velocity at Crank shaft (r_1) = $2 * \pi * n / 60$

$$\omega_1 = 2 * \pi * 360 / 60$$

$$= 37.69 \text{ rad/sec}$$

Find VB. Using vector diagram

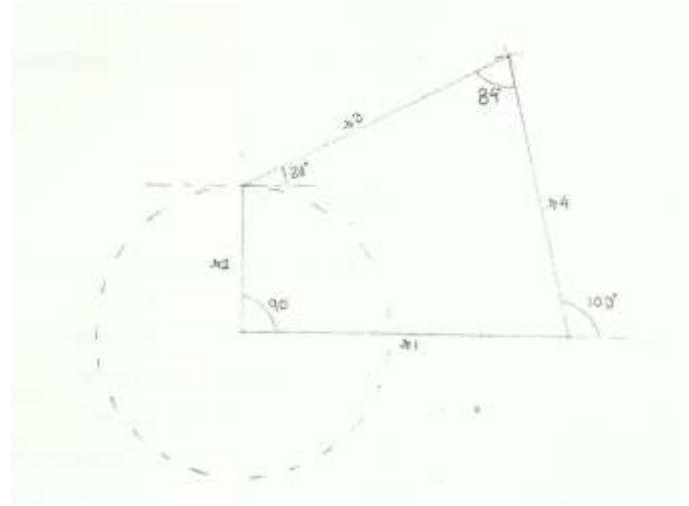

Fig. 4. Position Analysis ($\theta_1 = 90$ degree)

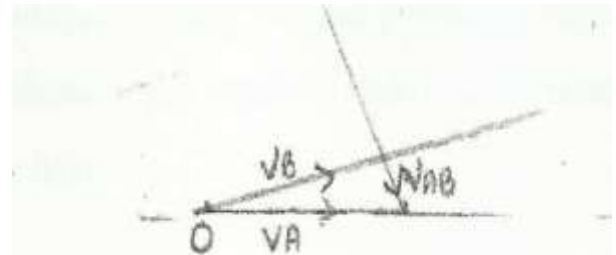

Fig. 5. Vector Diagram (Scale 1:10)

Measuring from the velocity diagram

$$V_b = 189.5 \text{ cm/sec}, V_{ba} = 36.7 \text{ cm/sec}, V_a = 150.79 \text{ cm/sec}$$

Measure the lengths of the linear velocities according to the velocity scale;

Divide these by their respective radius vectors.

$$\omega_2 = 36.7 / 8 = 4.587 \text{ rad/sec}$$

$$\omega_3 = 189.5 / 8.2 = 23.10 \text{ rad/sec}$$

Output Angle on Rocker Arm

Four bar Parameters:

$$r_1 = 0.090\text{m}, r_2 = 0.040\text{m}, r_3 = 0.082\text{m}, r_4 = 0.080\text{m};$$

when $\theta_1 = 90$ degrees

Linkage type: Crank-Rocker

Crank rotation 360 degree

Output Range:



Lower limit: $88.47^\circ - 152.18^\circ$
 Upper limit: $152.18^\circ - 88.47^\circ$
 Output angle $152.18^\circ - 88.47^\circ = 63.71^\circ$
 The rocker is oscillate 63.71°

Interactive Four-Bar Linkage Kinematic Analysis with Constant Angular Velocity for Link 2

Kinematic analysis deals with time dependent functions, such as velocity and acceleration of linkages. Linkage Designer provides a number of functions that helps analyze the translational and angular velocity, acceleration and also higher order derivatives of any links.

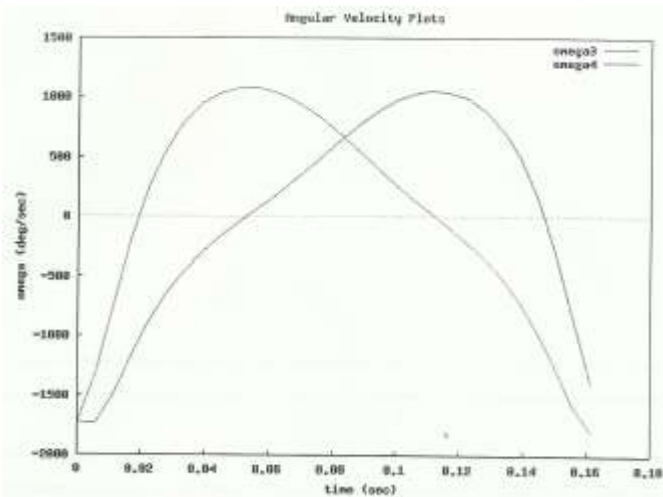

Fig. 6. Angular Velocity Plots

B. Design of Simple Gear Train

A gear train is formed by mounting gears on a frame so that the teeth of the gears engage. Gear teeth are designed to ensure the pitch circles of engaging gears roll on each other without slipping; this provides a smooth transmission of rotation from one gear to the next. A gear is a rotating machine part having cut teeth, or cogs, which mesh with another toothed part in order to transmit torque. Two or more gears working in tandem are called a transmission and can produce a mechanical advantage through a gear ratio and thus may be considered a simple machine.



Fig.7.Spur Gear

Mechanical Advantage

Gear teeth are designed so that the number of teeth on a gear is proportional to the radius of its pitch circle, and so that the pitch circles of meshing gears roll on each other without slipping. The speed ratio for a pair of meshing gears can be computed from ratio of the radii of the pitch circles and the ratio of the number of teeth on each gear. The mechanical advantage of a pair of meshing gears for which the input gear has N_A teeth and the output gear has N_B teeth is given by:

$$MA = \frac{T_B}{T_A} = \frac{N_B}{N_A}$$

If the output gear of a gear train rotates more slowly than the input gear, then the gear train is called a speed reducer. In this case, because the output gear must have more teeth than the input gear, the speed reducer will amplify the input torque.

Calculation of Mechanical Advantage:

$T_B =$ no. of teeth on Follower

$T_A =$ no. of teeth on Driver

$MA = 38/102 = 0.3725$

Velocity Calculation for the Gear Train

Where,

N_1 and N_2 are the r.p.m on driver and follower

T_1 and T_2 are the no. of teeth on driver and follower

ω_d and ω_f are the angular velocity of driver and follower

The value of ω_d comes from the 4 bar link mechanism

$\omega_d = \omega_3$

1 $\omega_d = 23.10 \text{ rad/sec}$

2 So the N_1 comes from

$\omega_d = 2\pi n / 60$

3 $23.10 = 2 * 3.14 * N_1 / 60$

4 $N_1 = 221 \text{ r.p.m}$

Now calculating the N_2

$T_1 / T_2 = N_2 / N_1$

$102 / 38 = N_2 / 221$

$N_2 = 594$

Now using the velocity relation find out the ω_f

$\omega_f = 2\pi N_2 / 60$

$\omega_f = 2\pi * 594 / 60$

$\omega_f = 62.20 \text{ rad/sec}$

The gear ratio of a gear train, also known as its speed ratio, is the ratio of the angular velocity of the input gear to the angular velocity of the output gear. [1] The gear ratio can be calculated directly from the numbers of teeth on the gears in the gear train. The torque ratio of the gear train, also known as its mechanical advantage, is determined by the gear ratio.

Mathematic expression for Gear Ratio

$i = Z_g / Z_p$ or N_g / N_p

Where Z_g and $Z_p =$ Teeth on gear and pinion

N_g and $N_p =$ R.P.M of gear and pinion

$i = 594 / 221 = 2.68$

Output Angle on Output Gear



The output of this gear train is not rotating; the output of this gear train is oscillating. The output gear is oscillating 0 to 172 degree. The calculation for this oscillating output is following

Where

θ_1 and θ_2 are the angle of gear and pinion

i is the gear ration

$$\theta_2 = i * \theta_1$$

$$\theta_2 = 2.70 * 63.71$$

$$\theta_2 = 172 \text{ degree}$$

C. Design of Oscillating Arm with Punch

The oscillating arm is the main part of the feed and punch machine. The oscillating arm is weld with the punch on one end and other end of the arm is joined with the output shaft of the gears. The oscillating arm is oscillating 0 to 172 degree. The arm is keyed with the output shaft from the gears.

D = diameter of the rod

d = diameter of punch

d_1 = diameter of the shaft

Where L = length of the arm

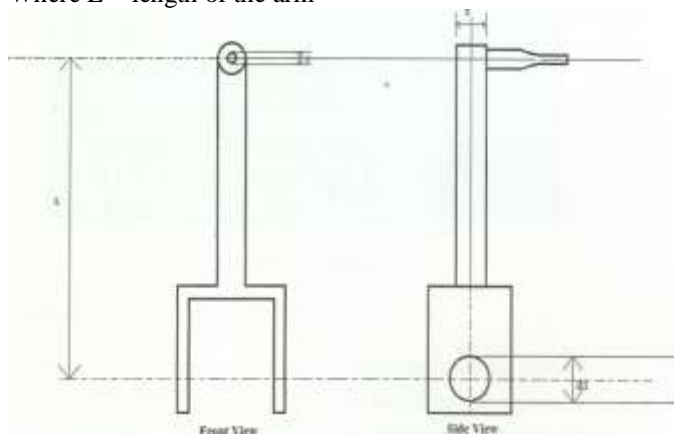

Fig.8. Oscillating Arm

The punch is made of HSS. The diameter of the punch is depends upon the work piece. Punching is a metal forming process that uses a punch press to force a tool, called a punch, through the work piece to create a hole via shearing. The punch often passes through the work into a table or dies. A scrap slug from the hole is deposited into the die or table in the process. Depending on the material being punched this slug may be recycled and reused or discarded. Punching is often the cheapest method for creating holes in sheet metal in medium to high production volumes. When a specially shaped punch is used to create multiple usable parts from a sheet of material the process is known as blanking.

Oscillating Arm

The oscillating arm is the main part of the feed and punch machine. The oscillating arm is weld with the punch on one end and other end of the arm is joined with the output shaft of the gears. The oscillating arm is oscillating 0 to 172 degree. The arm is keyed with the output shaft from the gears.

Measurements for the oscillating Arm

Length of the Arm = .255m

Weight of the Arm = 2 kg

Force Generated By the Arm

The force generated by the arm is centrifugal force.

The Centrifugal force is the apparent outward force that draws a rotating body away from the center of rotation. It is caused by the inertia of the body as the body's path is continually redirected. In Newtonian mechanics, the term centrifugal force is used to refer to one of two distinct concepts: an inertial force (also called a "fictitious" force) observed in a non-inertial reference frame, and a reaction force corresponding to a centripetal force.

Newton's third law states that for every acting force there is an equal and opposite reaction force Therefore there will be an equal and opposite reaction force to the Centripetal Force: the Centrifugal Force

Mathematic expression for Centrifugal Force

$$F_c = m * \omega^2 * r$$

Where F_c = Centrifugal Force

m = Mass of the arm

ω = Angular velocity

r = Radius arm

The values of the m , ω and r are following

$$m = 2 \text{ kg}$$

$$\omega = 62.20 \text{ m/sec}$$

$$r = .255 \text{ m}$$

$$F_c = 2 * 62.20^2 * .255$$

$$= 1973.10 \text{ N}$$

$$= 1.970 * 10^3 \text{ KN}$$

Ratchet

A ratchet is a mechanical device that allows continuous linear or rotary motion in only one direction while preventing motion in the opposite direction. Though something of a misnomer, "ratchet" is also often used to refer to ratcheting socket wrenches, a common tool with a ratcheting handle.

Operation of Ratchet

A ratchet consists of a round gear or linear rack with teeth, and a pivoting, spring loaded finger called a pawl that engages the teeth. The teeth are uniform but asymmetrical, with each tooth having a moderate slope on one edge and a much steeper slope on the other edge. When the teeth are moving in the unrestricted (i.e., forward) direction, the pawl easily slides up and over the gently sloped edges of the teeth, with a spring forcing it (often with an audible 'click') into the depression between the teeth as it passes the tip of each tooth. When the teeth move in the opposite (backward) direction, however, the pawl will catch against the steeply sloped edge of the first tooth it encounters, thereby locking it against the tooth and preventing any further motion in that direction.



Fig. 9. Ratchet

Use in Feeding Mechanism

The ratchet plays a main role in the feeding mechanism in feed and punch machine. The ratchet provide the one way feed in the machine, when the punching operation is start then the ratchet hold the sheet on the table, after the punching when punch back ward moment is start then the ratchet starts the feeding of the sheet on the table. The ratchet is always contact with the sheet. The feeding by the ratchet is frictional feeding. The Working shown in the figure When the ratchet rotates then the teeth of the ratchet give the notion to the workpiece or sheet horizontally.

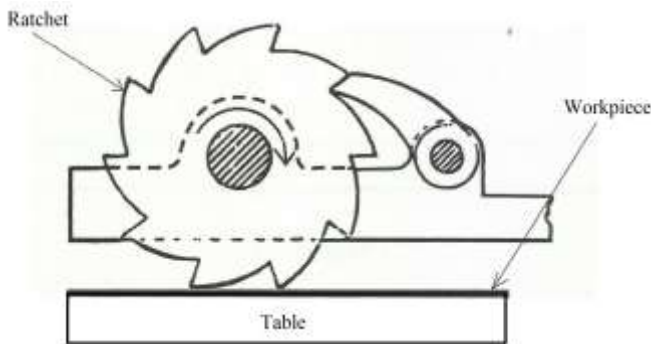

Fig. 10. Feed Mechanism with Ratchet

III. RESULT

The feed and punch machine is successfully design and the machine in working condition. The force produce by the machine is higher than the required force to punch in the sheet. The machine is successfully make the oscillating angle of near about 170 to 180 degree.

A. Required force

The force is produce by the machine that is centrifugal force. The force required to punch is calculate following

$$F = \pi d t \tau$$

Where d = diameter of hole to be punch

t = thickness of sheet

τ = shear stress of sheet

$$F = 2 * 1 * 210 * \pi = 1319.47 \text{ N} = 1.319 * 10^3 \text{ KN}$$

B. Power Required

Maximum fluctuation of energy or energy used per hole

$$\Delta E = I C_s \omega^2 * 1 \text{ O}6 \quad (1)$$

Where I = moment of inertia

C_s = coefficient of fluctuation of energy

ω = angular velocity

m = mass

k = radius of gyration

$$I = m k^2$$

$$I = 2 * 255^2 = 130050 \text{ N-m}$$

$$\omega = 62.20 \text{ m/sec}$$

The value of C_s is taking from the standard table no. 20.3 in the machine design data book by V.K.Jodon $C_s = 0.2$

Put the all values in eq. (1)

$$\begin{aligned} \Delta E &= 130050 * 0.2 * 62.20^2 \\ &= 100.62 \text{ N-m} \end{aligned}$$

Assume no. off pierces 60 holes in one minute and machine efficiency 80 %

Then the energy required for 60 holes in minute

$$\begin{aligned} &= \text{No. off holes pierces} * \text{energy used per hole} \\ &= 60 * 100.62 \\ &= 6037.71 \text{ N-m/min} \end{aligned}$$

Now Power need for the electric motor

$$\begin{aligned} P &= \text{Energy used per minute} / 60 * \eta \\ &= 6037.71 / 60 * 0.8 = 125.78 \text{ watt} \\ &= 0.12578 \text{ KW and horsepower} \\ \text{HP} &= 0.171 \text{ horsepower} \end{aligned}$$

IV. CONCLUSION

In this project the new Feed and Punch machine is present. The main difference between the other punching machine and Feed and Punch machine is there is no ideal stroke in the feed and punch machine. In other punching machine the external feeding mechanisms is required to feed the work piece but in the feed and punching machine the feeding mechanism is run mechanically, the feeding mechanism is design in that way the feeding mechanism is not included the load external load on the machine. In the punching machines the different motor is required to run the feeding mechanism, but in the feed and punching machine only one motor is able to run the machine with feeding mechanism efficiently.

A. Advantages of Feed and Punch Machine

The advantages of the Feed and Punch machine

1. In the Feed and Punch machine, no ideal stroke.
2. Only one motor is required to run the machine as well as the feeding mechanism
3. Able to produce high production.
4. No greater horsepower is required.
5. Accident chances are decreases.



6. No skilled labour is required.
7. Low initial cost.
8. Totally mechanical operated so less chances of electrical damage.

B. Future Work

In the future, the Feed and Punch Machine is used for cut the for heavy duty material after modification. Feed and Punching machine widely used in the future because of the no. off advantage of the machine. After the some modification in the Feed and Punch machine they able to work in the industry.

C. Limitations of the Feed and Punch Machine

The limitations of the Feed and Punch Machine are following

1. Due to the overall mechanical system, the wear and tear is more.
2. Skilled worker is required for maintenance.

V. REFERENCE

- [1] Machine Design by Khurmi
- [2] Theory of Machine by R.S. Khurmi, J.K. Gupta
- [3] Machine design data book 2 Edition by V.K. Jodao and Suresh Verma

IJEAST

INTERNATIONAL JOURNAL
OF ENGINEERING APPLIED SCIENCE
AND TECHNOLOGY

ABOUT IJEAST

International Journal of Engineering Applied Science and Technology (IJEAST) is a peer-reviewed, open access journal that publishes high-quality research papers in the field of Engineering, Applied Science and Technology.

IJEAST aims to provide a platform for researchers, academicians, and professionals to share their innovative ideas, research findings, and practical experiences with the global scientific community.

FOCUS AREAS

- Engineering
- Applied Science
- Technology
- Innovation & Development
- Interdisciplinary Studies



PEER REVIEWED

All submissions are rigorously peer reviewed to ensure quality.



OPEN ACCESS

Free and unrestricted access to research for all.



GLOBAL REACH

Connecting researchers and professionals worldwide.



TIMELY PUBLICATION

We ensure a swift and efficient publication process.



For more information, visit our website
www.ijeast.com



INTERNATIONAL JOURNAL
OF ENGINEERING APPLIED SCIENCE
AND TECHNOLOGY

✉ editor@ijeast.com

🌐 www.ijeast.com

📍 India



2455-2143