



IJEAST

INTERNATIONAL JOURNAL
OF ENGINEERING APPLIED SCIENCE
AND TECHNOLOGY



VOLUME : 2 ISSUE : 5 Print / Issue Publication Date: 11-Aug-2017



ISSN : 2455-2143



Indexed In



WWW.IJEAST.COM

editor@ijeast.com



IMPLEMENTATION OF MPPT IN A HIGH STEP-UP INTERLEAVED CONVERTER FOR GRID CONNECTED APPLICATIONS

Shyma H

PG Scholar, Department of EEE
MACE Kothamangalam,
Kerala, India.

Smitha Paulose

Asst. Professor, Department of EEE
MACE Kothamangalam
Kerala, India

Eldhose K A

Asst. Professor, Department of EEE
MACE Kothamangalam
Kerala, India

Abstract— The DC-DC converters are widely used in photovoltaic generating systems as an interface between the photovoltaic panel and the load. The photovoltaic cells which give a very low output voltage are used in most of the applications. The DC-DC boost converter has to be connected with the renewable energy source in order to increase the available voltage for various high voltage gain applications. Here a PV system is proposed which consists of a DC-DC boost converter with MPPT algorithm. Boost converter suffers from large input current ripple. In order to improve the efficiency of the boost converter and reduce the ripple current, an interleaved boost converter is used. An interleaved boost converter consists of several boost converters connected in parallel with switching frequency and a phase shift of 180 degree. A new interleaved high step up converter with the circuit of cumulative voltage unit (CVU) is implemented in this work. This converter is suitable for the high gain applications. Only two switches are required to form the boosting path and the interleaved topology. In this work, perturb and observe (P&O) method is used to extract maximum possible power from solar panel. Fractional open circuit voltage method is used in hardware as it is simple and easy to implement. A high gain step-up converter which is suitable for grid-connected renewable energy sources is simulated using MATLAB/SIMULINK and experimental results are also verified.

Keywords— Cumulative voltage unit, Boost converter, Interleaved boost converter, Voltage Stress.

I. INTRODUCTION

In recent years, due to the fast environmental change and energy exhaustion, the application ranges of the renewable energy is extended more and more. The DC-DC step-up converter is one of the possible applications. In general, the voltage generated from the green energy is through the DC-DC converter to step up the voltage. Then the inverter is used to convert the dc source to the ac source to be in parallel with the utility grid to provide the energy to the load. In a

conventional boost converter, the stray inductance, capacitor, voltage stress, ESR of the capacitor, and reverse recovery problem of the diode make it unable to produce the necessary high voltage in the real applications. The disadvantages of conventional boost converter have been overcome by using an interleaved boost converter. A multiphase interleaved boost converter consists of several boost converters connected in parallel with switching frequency and a phase shift of 180 degree. As the number of stages increases the efficiency is also improved correspondingly [1]. To minimize the amount of ripple, the conventional boost converter has been replaced by an improved operation of interleaving methodology. In this work a new interleaved high step-up DC-DC converter with the circuit of cumulative voltage unit is used for high power applications. Due to economic causes the solar energy is not directly interfaced with the utility grid. Thus a power electronic device is employed to interface the solar system to the grid. MPPT algorithms are necessary because PV arrays have a non linear voltage-current characteristic with a unique point where the power produced is maximum. This point depends on the temperature of the panels and on the irradiance conditions. Both conditions change during the day and are also different depending on the season of the year. It is very important to track the MPP accurately under all possible conditions so that the maximum available power is always obtained.

In the recent years, the high step up DC-DC converters are playing a vital role in DC-back up energy system for UPS, grid system, high intensity discharge lamp and automobile applications also. The conventional boost converter can be advantageous for step-up applications that do not demand very high voltage gain, mainly due to the resulting low conduction loss and design simplicity. The duty cycle of the conventional boost converter has its limitation to step up the output voltage. A new interleaved high step-up DC-DC converter with the circuit of cumulative voltage unit is used for high power applications. Only two switches are required to form the double boosting path and the interleaved topology [5]. The new technique of the cumulative voltage unit forms the post part of the high step-up converter. Each CVU module can



share common diodes to reduce the number of the components, step up the voltage gain and clamp the voltage effectively [5]. The interleaved structure in the input end can reduce the power loss in each current-owing component and the input current ripple. Thus this paper includes the implementation of MPPT using P & O algorithm in an interleaved high step-up DC-DC converter using cumulative voltage unit.

II. IMPLEMENTATION OF MPPT IN A HIGH STEP-UP INTERLEAVED CONVERTER

Fig. 1 shows the proposed system . The DC-DC converter is suitable for high gain applications. Only two switches are required to form the double boosting path and the interleaved topology. The new technique of the cumulative voltage unit forms the post part of the high step-up converter. Each CVU module can share common diodes to reduce the number of the components, step up the voltage gain and clamp the voltage effectively. The interleaved structure in the input end can reduce the power loss in each current-owing component and the input current ripple. The CVU modules can be arranged with different manners to extend the circuit topology. The duty cycle of DC-DC converter is controlled by using MPPT algorithm for maximum power point tracking using P & O algorithm and is used for grid connected applications.

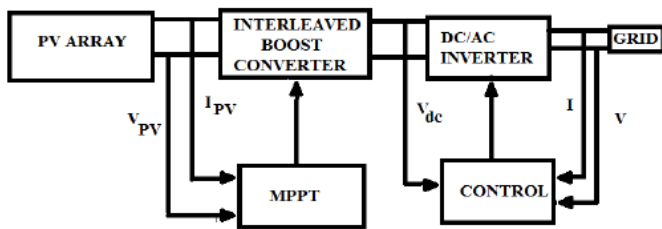

Fig. 1. Proposed System

A. An Interleaved High Step-Up Dc-Dc Converter with Cumulative Voltage Unit-

The high gain interleaved boost converter is suitable to the application of requiring high ratio of the output voltage to input voltage. Only two switches are required to form the double boosting path and the interleaved topology. The new technique of the cumulative voltage unit forms the post part of the high step-up converter. Each CVU module can share common diodes to reduce the number of the components, step up the voltage gain and clamp the voltage effectively. The interleaved structure in the input end can reduce the power loss in each current-owing component and the input current ripple. The CVU modules can be arranged with different manners to extend the circuit topology. Fig. 2 shows the circuit diagram of Interleaved Boost Converter with Voltage Cumulative Unit.

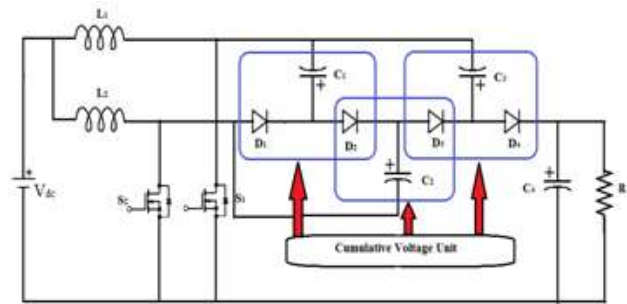

Fig. 2. Circuit Diagram of High gain Interleaved Boost Converter

Here S_1 and S_2 are power switches. C_1, C_2, C_3, C_4 are capacitances. L_1 and L_2 are the input inductance and each cumulative voltage unit is specified in the fig. 2. Conventional and interleaved boost converters have some common drawbacks. The duty cycle of these boost converters has its limitation to step up the output voltage. For high power applications it require large value of duty cycle. Extreme value of duty cycle is affected by the design of circuit. The voltage stress across the switch is almost equal to output voltage in both cases. Therefore it is necessary to provide high output voltage without using extreme value of duty cycle. It helps to provide low ratings of components and thus helps to reduce the size of the circuit. So we use interleaved boost converter with cumulative voltage unit. Here high gain converter provide an output voltage which is 14.5 times greater than input voltage.

B. Perturb & Observe MPPT algorithm-

The basic idea of the algorithm is to periodically perturb the duty cycle of the converter and measure the module current and voltage to determine the power. Based on the difference of the present & past values of voltage, the direction of perturbation is decided. Fig. 3 shows the P-V characteristics of PV panel. The basic algorithm uses a fixed step to increase or decrease voltage. The size of the step determines the size of the deviation while oscillating about the MPP. Having a smaller step will help reduce the oscillation, but will slow down tracking, while having a bigger step will help reach MPP faster, but will increase power loss when it oscillates. To be able to implement P & O MPPT, the application needs to measure the panel voltage and current. So for implementation it needs two sensors.

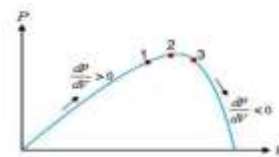

Fig. 3. P-V Characteristics of PV Panel



C. Fractional Open Circuit MPPT algorithm–

The maximum power point voltage has a linear dependency on the open circuit voltage V_{OC} under different irradiance and temperature conditions. Computing the MPP (Maximum Power Point) comes down to: $V_{MPP}=K_V V_{OC}$. The constant k depends on the type and configuration of the photovoltaic panel. The open circuit voltage must be measured and the MPP determined for different ambient conditions. Usually, the system disconnects the load periodically to measure V_{OC} and calculate the operating voltage. Fig. 4 shows the block diagram of FOC voltage method. Although this method is quite simple and robust. The controller is programmed to operate the PV at maximum power point. A PI controller is implemented with their respective gains to obtain the converter operation at maximum power point of PV source.

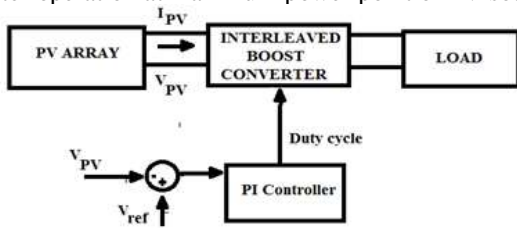

Fig. 4. Block Diagram of FOC Voltage Method

III. SIMULATION RESULTS

The converter as well as the MPPT algorithms are simulated in MATLAB/ SIMULINK.. High gain interleaved boost converter without MPPT is designed for 24 V input, 350 V output with switching frequency of 60 kHz and duty cycle 72%. Output power is assumed as 150 W. Fig. 5 shows the simulink model of high gain interleaved boost converter with cumulative voltage unit and without MPPT algorithm. The simulated waveform of switching waveform, input current, voltage stress across the switch, output voltage and current are shown in simulation results. The input current contains a ripple of 0.8A and the voltage stress is 4 times reduced as that of output voltage. 180° interleaved overlapped pulses are used. The control signals with duty ratio 0.72 are shown in fig. 6. The simulation parameters are shown in table -1.

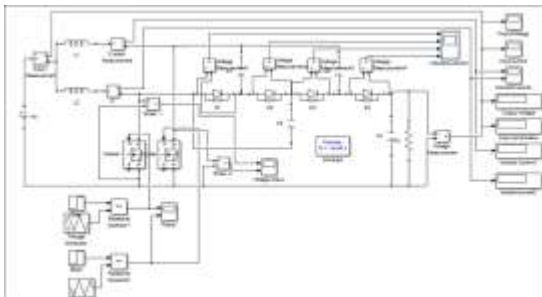

Fig .5. Simulink model of high gain converter without MPPT

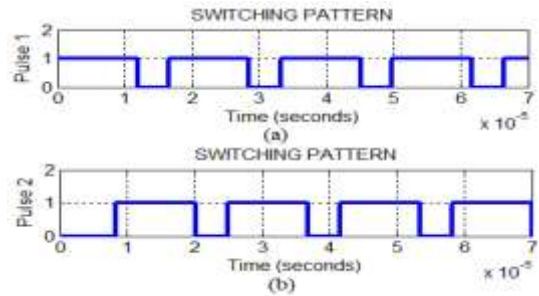

Fig .6. Control pulses of (a)Switch S_1 (b)Switch S_2

Table -1 Simulation parameters.

PARAMETERS	VALUES
Input voltage	24V
Output voltage	350V
Switching frequency	60kHz
Duty cycle	72%
Boost inductors (L_1 & L_2)	218 μ H
Boost capacitors (C_1 C_2 C_3)	220 μ F
Output capacitor (C_o)	220 μ F

Fig. 7 shows the source current and inductor currents for interleaved boost converter with CVU. The voltage impressed across the inductor during the on period of switch is V_{in} . During this period current rises linearly from a minimum level I_{min} to a maximum level I_{max} . The voltage impressed across the inductor during OFF period is $V_{out}-V_{in}$ and current drops linearly from the maximum level I_{max} to minimum level I_{min} . The sum of inductor current will be the source current.

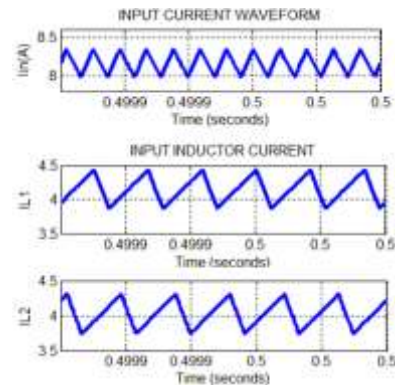

Fig .7. Input current waveform

It is evident from the simulation result that voltage across switch 1 is zero when the switch S_1 is ON for a time period of 72% and voltage across switch S_1 is 4times less than output voltage when S_1 is OFF. Waveform for voltage across switch S_2 is similar to that of S_1 but is 180 degree phase shifted. Fig. 8 shows the voltage waveform across MOSFET.

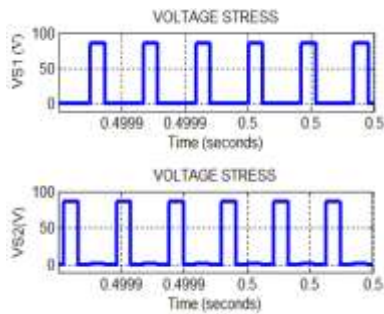

Fig. 8. Voltage Stress across the Switch

Fig. 9 shows the output voltage and current of the interleaved boost converter with CVU. It is clear from the simulation result that output voltage greater than its input voltage. Steady state output voltage is obtained as 332 V and output current is 0.47 V.

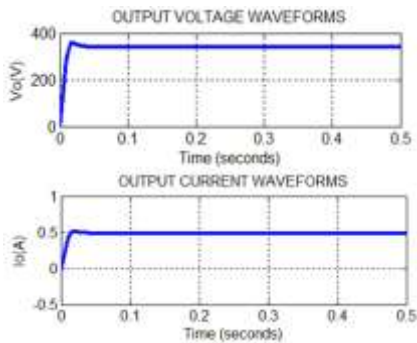

Fig. 9. Output voltage waveform

The BP SOLAR SX 3190 is selected as the PV module from the MATLAB tool box to verify the MPPT algorithms. The characteristics of the module is given in fig. 10.

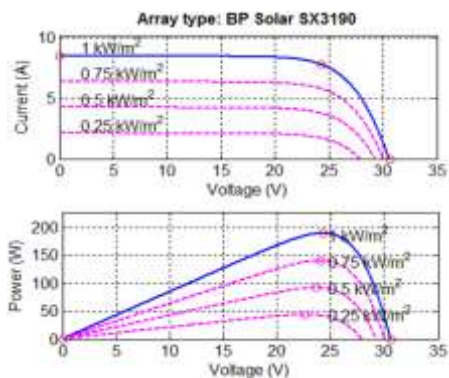

Fig. 10. Characteristics of BP Solar SX3190.

I-V and P-V characteristics of the PV array under varying irradiance with fixed ambient temperature are shown in fig. 10. From the characteristics of PV array, it can be seen that, PV panel has its MPP at different point for different irradiance level.

Fig. 11 and fig. 13 shows the simulink model of FOCV method and P & O method. Fig. 12 shows the simulation results of FOCV method. To operate the PV panel at the MPP, the actual PV array voltage V_{pv} is compared with the reference voltage V_{ref} which corresponds to the V_{mpp} . The error signal is then processed to make $V_{pv} = V_{ref}$. In order to verify MPPT operation, the condition of changing irradiance from $500W/m^2$ to $1000W/m^2$, at $25^\circ C$ is set using signal builder and a R load. From the P-V characteristics (fig. 10), it can be seen that, at $1000W/m^2$, maximum power is 190W and for $500W/m^2$, maximum power is 95W. The variation in PV power, voltage and current with the change in irradiance is shown in fig. 11. At simulation time 1.5s, there is an increase in solar insolation from $500W/m^2$ to $1000W/m^2$ and thus power increases from 95W to 190W, i.e. corresponding MPP. Duty cycle is adjusted by the MPPT algorithm to track maximum power point.

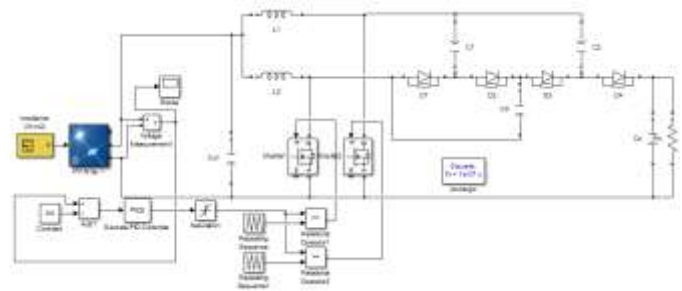

Fig. 11. Simulink model of FOCV MPPT algorithm

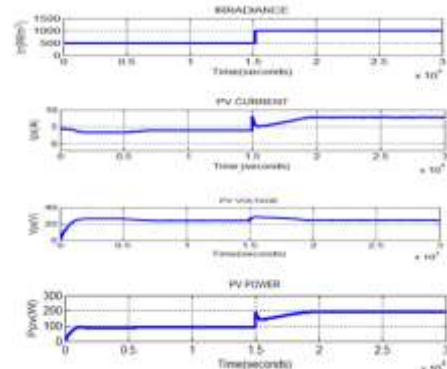

Fig. 12. Simulation results FOCV MPPT algorithm

Voltage and current from the PV module is sensed and fed to the MPPT algorithm block to track the maximum power point frequency. P & O MPPT algorithm is implemented in MATLAB function block. Program is in embedded c language. Similar to FOCV voltage method an irradiance change from $500 W/m^2$ to $1000 W/m^2$ is given to test the MPP tracking. Maximum power tracking is evident from the simulation graph shown in fig. 14.

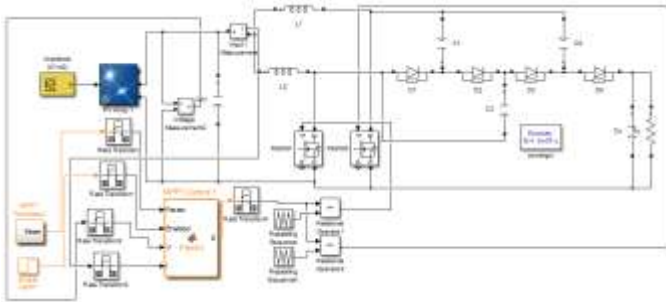

Fig. 13. Simulink model of P&O MPPT algorithm

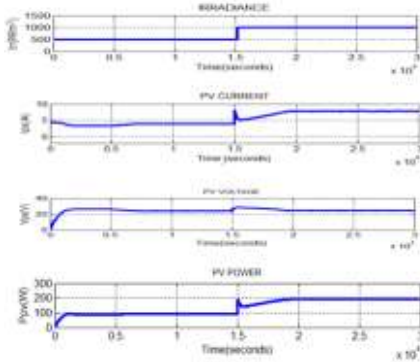

Fig. 14. Simulation results P&O MPPT algorithm

IV. EXPERIMENTAL RESULTS

Hardware setup is done in a Printed Circuit Board (PCB). Control circuit and power circuit are implemented in one PCB. Here dsPIC30F2010 is used for generating a pulse of constant duty cycle and switching frequency.. The components list for the hardware is given in Table 2.

Table -2 Component List.

PARAMETERS	VALUES
Input voltage	24V
Output voltage	350V
Switching frequency	60kHz
Diode	UF5400
MOSFET	IRF540
Boost inductors (L_1 & L_2)	220 μ H
Boost capacitors (C_1, C_2, C_3)	47 μ F
Output capacitor (C_o)	47 μ F
Controller	dsPIC30F2010
Driver IC	TLP250

Fractional open circuit voltage method is implemented and indoor testing of the circuit has been performed. This is the

simplest and cost effective method of all the MPPT methods. P & O method requires high accuracy current sensor to sense the PV current which increases the cost. Instead of using a PV source, MPP tracking can be verified using an indoor arrangement. Experimental setup is shown in 14.



Fig. 15. Experimental set up

The output voltage obtained for an input of 24V is shown in fig. 15. The multimeter shows the output voltage of 328V . The practical voltage gain is slightly less than the theoretical one because of the on state resistance of power semiconductor devices.

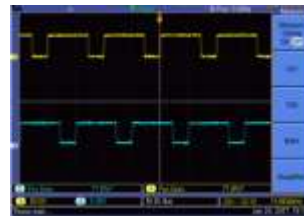
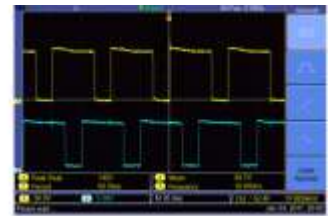

Fig. 16(a) Pulse from dsPIC30F2010



(b) Output of TLP250

As seen from fig. 15, input voltage source settles at reference set point (here 24V), because of the control loop provided for FOC voltage operation.180 degree phase shifted pulse output from the controller is shown in fig. 16(a). Output pulse from driver IC which is of 12V is shown in fig. 16(b).Voltage stress across the switches will be 4 times less than output voltage. Both volt age across switch and pulse of respective switch are shown in fig. 17(a) and fig 17(b).

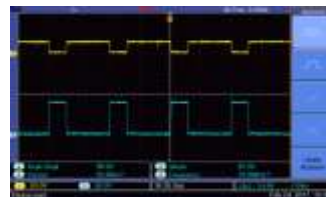
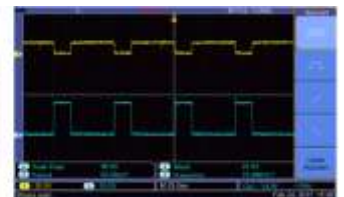

Fig. 17: (a) Voltage Stress across S_1



(b) Voltage stress across S_2



V. CONCLUSION

In this project, a high gain interleaved boost converter that makes use of solar energy with a proper MPPT control to work with maximum efficiency is presented. The modified circuit based on interleaved technique and voltage cumulative unit helps in current sharing capability can reduce the conduction loss of the components and helps to use the smaller inductors. It helps to provide output voltage as that of conventional converters without using extreme values of duty cycle. The input current ripple is reduced by 60% compared to conventional boost converter. The CVU circuit is used to make up the high step-up DC-DC converter. The CVU circuits can share the common diodes effectively to reduce the number of the diodes and can also increase the voltage gain. The voltage stress across the switches is reduced by 74%. Therefore, the components with smaller rating and lower conduction resistance can be chosen to increase the efficiency of the circuit. In hardware setup, fractional open circuit voltage method is as it is simple and easy to implement. And voltage gain is improved by 14 times and also MPPT is verified assuming a V_{MPP} of 24V. Thus it will help to provide maximum power point voltage at which the complete system operate efficiently.

VI. REFERENCES

- [1] P. Sivachandran, S. Benisha and C.S. Dhanalakshmi, "Review on High Step up DC-DC Converter for High Voltage Gain", *Middle-East J. Sci.*, February 2011.
- [2] M.Arun Devil, K.Valarmathi, R.Mahendran, "Design and implementation of interleaved boost converter for fuel cell applications", *IJPEDS*, Vol.1, No.2, December 2014.
- [3] K. Radhalakshmi, R. Dhanasekaran, "High Voltage Gain Boost Converter for Micro source Power Conversion system", *IJREAT*, July, 2013.
- [4] Nikhil M. Waghmare, Rahul P. Argelwar, "High Voltage Generation by using Cockcroft-Walton Multiplier", *IJSETR*, Volume 4, Issue 2, February 2015.
- [5] Yie-Tone Chen and Wei-Cheng Lin, "An Interleaved High Step-Up DC-DC Converter with Cumulative Voltage Unit", *IEEE Transactions on Power Electronics*, Vol. 25, No. 9, September 2016.
- [6] Reshma M, Sheeja G, Sreehari G Nair, "Effect of Voltage Multiplier Cell in High Gain DC-DC Converter", *IJREAT*, Vol. 4, Issue 7, July 2015.
- [7] D. D. Gaikwad, M. S. Chavan, "Hardware Implementation of DC-DC Converter for MPPT in PV Applications", *IEEE Global Conference on Wireless Computing and Networking*, 2014.
- [8] A. Pradyush Babu, B. Sai Pranahita, "Hardware Realization of Conventional MPPT Techniques", *International Journal of Engineering Research & Technology*, Vol. 4 Issue 06, June-2015.
- [9] K. I. Hwu, Y. T. Yau, "A KY Boost Converter", *IEEE Transactions on Power Electronics*, Vol. 25, No. 9, September 2009.
- [10] Ned Mohan, Undeland and Robbin, *Power Electronics: converters, Application and design* John Wiley and sons, Inc, Newyork, 1995.
- [11] Pratima Das, "Maximum Power Tracking Based Open Circuit Voltage Method for PV System", *5th International Conference on Advances in Energy Research*, December 2015, Mumbai, India.
- [12] M. Marimuthu, A. Kamalakkannan, "Interleaved Boost Converter with MPPT Controller for Photovoltaic System", *MIT International Journal of Electrical and Instrumentation Engineering*, Vol. 2, No. 2, Aug. 2012.
- [13] Wuhu Li, Yi Zhao, Yan Deng, and Xiangning He, "Interleaved Converter With Voltage Multiplier Cell for High Step-Up and High-Efficiency Conversion", *IEEE Transactions on Power Electronics*, Vol. 25, No. 9, September 2016.
- [14] L. Elbaz, S. Tapuchi, "Novel Optimized Method for Maximum Power Point Tracking in PV Systems Using Fractional Open Circuit Voltage Technique", *International Symposium on Power Electronics, Electrical Drives, Automation and Motion*, Vol. 25, No. 9, September 2016.
- [15] Kshitijaa Ranjan, Narendra Kumar, "Modelling and Simulation of Perturb and Observe Algorithm on Solar PV System using Different Converters in MATLAB/Simulink", *1st IEEE International Conference on Power Electronics. Intelligent Control and Energy Systems*, Aug. 2016.
- [16] Bikram sah, Satish Kumar, "A Comparative study of different MPPT techniques using different dc-dc converters in a standalone PV system", *1st IEEE International Conference on Power Electronics. Intelligent Control and Energy Systems*, Aug. 2016.
- [17] Abhishek Kumar Gupta, Ravi Saxena "Review on widely-used MPPT Techniques for PV Applications", *1st International Conference on Innovation and Challenges in Cyber Security*, June 2016.
- [18] Syam M S, T.Sreejith Kailas, "Grid Connected PV System using Cuk Converter", *International Conference on Microelectronics, Communication and Renewable Energy*, December 2013.
- [19] A.Attou, A.Massoum, "Photovoltaic Power Control Using MPPT and Boost Converter", *Balkan Journal of Electrical and Computer Engineering*, Vol. 2, No. 1, September 2014.
- [20] *Engineering Research.*, Volume 4, Number 2, 2014.

IJEAST

INTERNATIONAL JOURNAL
OF ENGINEERING APPLIED SCIENCE
AND TECHNOLOGY

ABOUT IJEAST

International Journal of Engineering Applied Science and Technology (IJEAST) is a peer-reviewed, open access journal that publishes high-quality research papers in the field of Engineering, Applied Science and Technology.

IJEAST aims to provide a platform for researchers, academicians, and professionals to share their innovative ideas, research findings, and practical experiences with the global scientific community.

FOCUS AREAS

- Engineering
- Applied Science
- Technology
- Innovation & Development
- Interdisciplinary Studies



PEER REVIEWED

All submissions are rigorously peer reviewed to ensure quality.



OPEN ACCESS

Free and unrestricted access to research for all.



GLOBAL REACH

Connecting researchers and professionals worldwide.



TIMELY PUBLICATION

We ensure a swift and efficient publication process.



For more information, visit our website

www.ijeast.com



INTERNATIONAL JOURNAL
OF ENGINEERING APPLIED SCIENCE
AND TECHNOLOGY

✉ editor@ijeast.com

🌐 www.ijeast.com

📍 India



2455-2143