



IJEAST

INTERNATIONAL JOURNAL
OF ENGINEERING APPLIED SCIENCE
AND TECHNOLOGY



VOLUME : 6 ISSUE : 1 Print / Issue Publication Date: 08-Aug-2021



ISSN : 2455-2143



DOI : 10.33564/IJEAST.2021.v06i01.025

Indexed In



WWW.IJEAST.COM

editor@ijeast.com

MODIFIED QUADRATIC BUCK BOOST CONVERTER FOR PV APPLICATIONS

Aparna Mohan S
PG Scholar, Dept of EEE
Government Engineering College,
Bartonhill, Thiruvananthapuram

Prof. Anjana K R
Associate Professor, Dept of EEE
Government Engineering College,
Bartonhill, Thiruvananthapuram

Abstract—Buck-boost DC/DC converters have been extensively employed in stepping up/down the voltage for PV applications. The input and the output port current of the traditional quadratic buck-boost converter are discontinuous, which result in increased input and output current ripples and complicate the design of the input and output filters. Hence these problems can be solved by using a modified quadratic buck boost converter, which provides wider voltage conversion ratio with continuous input and output ports current. Dual output can be derived from this single input converter for multiple output applications. Also a fuzzy logic controller can be designed for this proposed converter for better and faster performance.

Index Terms—Buck-boost DC/DC converters, voltage conversion ratio, quadratic buck boost converter, FLC

I. INTRODUCTION

Nowadays, renewable energy systems such as fuel cell stacks and photovoltaic power systems are becoming one of the most attractive and promising sources of providing electrical energy compared to the conventional fossil fuel energy generating sources. With the elevation of the power electronic technology, awareness about the effects of exhaustible energy sources on the environment, the employment of inexhaustible energy sources have gained more importance as a future energy source. However, these alternative energy systems have an output, whose voltage is variable, depending on various environmental conditions. Works related to quadratic relationship of input and output voltages are recently analysed because of its wider conversion ratio[1]-[2]. Plenty of studies have been flourished and described on quadratic buck converters, where some investigations have been done on the mathematical modelling, methods of control [3]-[7] and quadratic boost converters where its novel topologies[8]-[11] were analyzed . But only a few investigations are done on quadratic buck-boost converters. These converters are less expensive, better structured besides the regular quadratic boost converter.

Few research works on conventional quadratic buck-boost converters which is created by combining two conventional

buck-boost converters where the input and output current are not continuous [12] and the application area where the converter can be used like energy stocking devices similarly batteries/supercapacitors with electrical and electrochemical principle was analysed [13].

High step up/step down voltage gain can be obtained by using a transformer less buck boost converter [14]. Even though its construction is simple, it produces naturally discontinuous input and output current. Two synchronously operating switches are responsible for their discontinuous input and output waveforms. The soft switching in this converter was obtained by introducing two resonant networks [15]. The switches are not subjected to high switch voltage or current stresses and, consequently, present low conduction losses. But it consist of more number of components than other configurations. So these limitation is solved by using single switch quadratic buck boost converter. As the name suggests, it consists of only one switch.

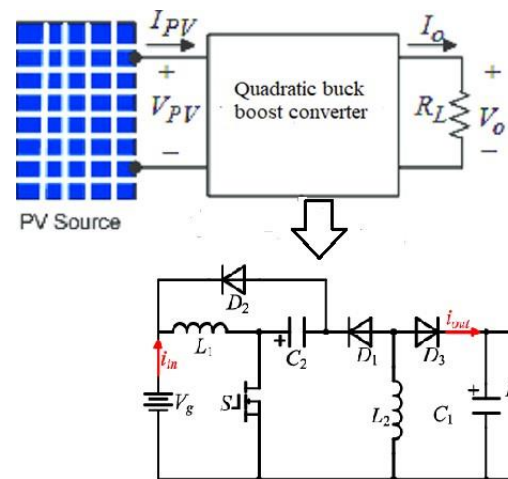

Fig. 1. Traditional quadratic buck boost converter system

Traditional quadratic buck-boost converter as shown in Fig.1, encounters increased input and output ripple currents with discontinuous input and output currents causing complexity in construction of i/p and o/p filters [16]-[17]. It is formed by combining two ordinary step-down-up converters.



As the inductor current is alike to the i/p current during turn on of switch, the L_2 inductor current is alike to the o/p current during switch turn off. Hence the input and output current are not continuous. This was overcome by quadratic buck boost converter with continuous input and output port current, which uses only one switch as in Fig. 2.

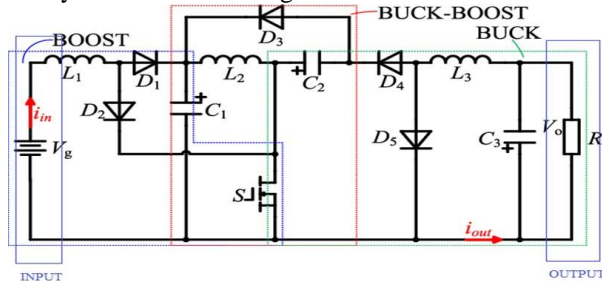

Fig. 2. Existing Converter

But for many applications, well-regulated power supplies with multiple outputs are needed. In the modern world fields such as industries, telecommunication, LED drivers, dc based nano grid etc. require multiple output because of the auxiliary circuits present in those system other than main circuit [18]. So that the researches on single input multiple output DC-DC converters are going on in order to get a less bulky system and more reliable control strategy.

So a dual output quadratic buck boost converter with continuous input and output port current controlled by a fuzzy logic controller is proposed for faster and stable response control. It uses only one switch. The ripples present in output current and output voltage are lower than the proposed structures in existing literature. The modified converter has wide range of voltage conversion ratio with same duty cycle.

II. PROPOSED SYSTEM

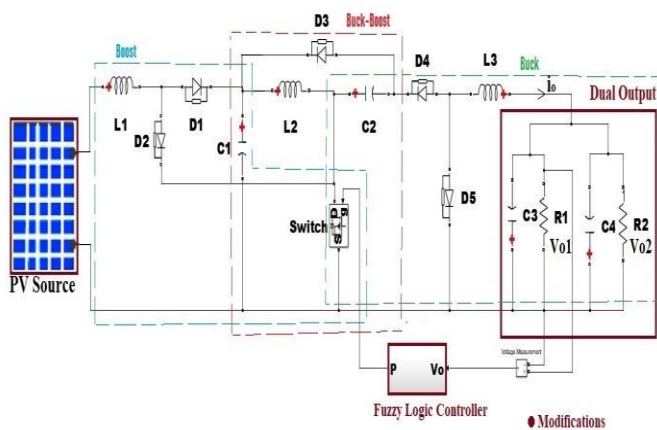

Fig. 3. Proposed System

Fig. 3 shows the overall circuit of proposed system. It is mainly composed of three different types of converters. First at the beginning of the circuit, there is a boost converter, followed by a buck-boost converter as an intermediate stage and finally a buck converter is placed as the last stage of the converter. It employs a single switch that is placed such that it can control the three different sections at the same time. The boost converter consists of input source V_{in} , diodes D_1 and D_2 , inductor L_1 , capacitor C_1 , and switch S . The buck-boost converter consists of capacitors C_1 and C_2 , inductor L_2 , diode D_3 , and switch S . The buck converter consists of capacitors C_2 , C_3 and C_4 , diodes D_4 and D_5 , inductor L_3 , switch S , and load resistors R_1 and R_2 . And also $V_{o1} = V_{o2} = V_o$ (Output voltage). It can be seen that the output capacitor of the boost converter is the input source of the buck-boost converter while the output of the buck-boost converter is the input source of the buck converter. It is of interest to note that there is an inductor connected in the input port and an inductor connected in the output port of the converter, which can contribute to the unique feature of drawing continuous input port current and continuous output port current.

With the help of fuzzy logic controller we can regulate the output as per the need of voltage requirement. Required level of output voltage can be maintained by the employment of closed loop control thereby enhancing production of system. With the help of this control techniques settling time of the output voltage can be reduced. For comparing the performance of fuzzy logic controller, PI controller based on tyreus Luyben(T-L) tuning method is formulated.

$$\text{Conversion ratio of converter, } M = \frac{V_o}{V_{in}} = \left(\frac{D}{1-D}\right)^2 \quad (1)$$

When the duty ratio(D) is below 50%, the converter act as buck and when the duty ratio is above 50%, the converter act as boost converter. The working of the circuit can be explained by two modes of operation.

Similar to other buck-boost converters, the proposed converter can theoretically operate in both continuous inductor current mode and discontinuous inductor current mode. However, since the continuous inductor current mode is normally preferred in many industrial applications to reduce the current ripple and also operating with continuous input and output current is a main benefit of the proposed converter.

A. Operation of Converter

When the switch is turned on, all of the diodes 1, 3, and 5 are turned off while diodes 2 and 4 are turned on as shown in Fig. 4. On the contrary, when the switch is off, diodes 2 and 4 are off while diodes 1, 3, and 5 are on as shown in Fig. 5. At this point, each mode has its own component function and behavior, which is different from the other sections and it is explained in the following subsections.

1) *Mode 1:* As shown in figure 4, the switch S is conducting, diodes D_2 and D_4 are in ON state, and diodes D_1 ,



D_3 , and D_5 are reverse-biased by v_{c1} , $v_{c1} + v_{c2}$, and v_{c2} , respectively. The input source V_{in} delivers power to the inductor L_1 through the diode D_1 and the switch S , meantime, the energy stored in capacitors C_1 and C_2 is being released to inductors L_2 and L_3 , respectively. Some of the main equations among the components in this mode are as follows:

$$L_1 \frac{di_{L1}}{dt} = V_g, \quad L_2 \frac{di_{L2}}{dt} = V_{c1}, \quad L_3 \frac{di_{L3}}{dt} = V_{c2} - V_o \quad (2)$$

$$\begin{aligned} C_1 \frac{dV_{c1}}{dt} &= i_{L2}, & C_2 \frac{dV_{c2}}{dt} &= i_{L3} \\ C_3 \frac{dV_o}{dt} &= C_4 \frac{dV_o}{dt} = i_{L3} - \frac{V_o}{R} \end{aligned} \quad (3)$$

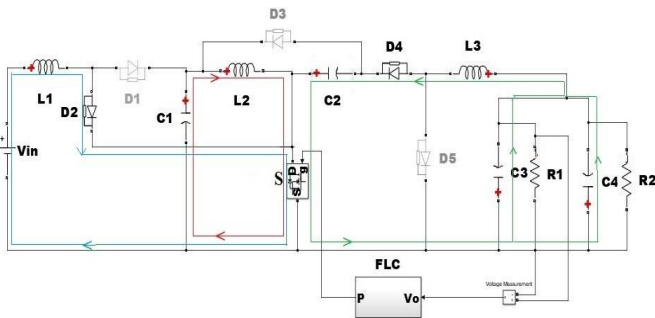

Fig. 4. Mode 1

2) **Mode 2** : As shown in Fig. 5, the switch S is turned OFF, diodes D_1 , D_3 , and D_5 are in ON state, and diodes D_2 and D_4 are reverse-biased by v_{c2} and v_{c1} , respectively, in this operating mode. The energy stored in the inductor L_1 as well as the input source is delivered to the capacitor C_1 , and the capacitor C_1 starts to store energy. The inductor L_2 discharges energy to the capacitor C_2 through the diode D_3 . At the same time, the inductor L_3 discharges energy to the capacitor C_3 and C_4 and load resistors. Some of the main equations among the components in this mode are as follows:

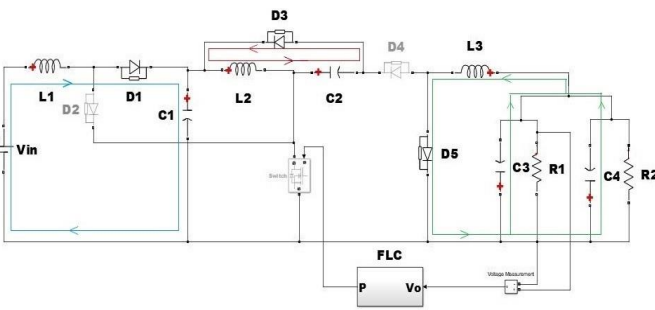

Fig. 5. Mode 2

$$L_1 \frac{di_{L1}}{dt} = V_g - V_{c1}, \quad L_2 \frac{di_{L2}}{dt} = -V_{c2}, \quad L_3 \frac{di_{L3}}{dt} = -V_o \quad (4)$$

$$\begin{aligned} C_1 \frac{dV_{c1}}{dt} &= -i_{L1}, & C_2 \frac{dV_{c2}}{dt} &= -i_{L2}, \\ C_3 \frac{dV_o}{dt} &= C_4 \frac{dV_o}{dt} = i_{L3} - \frac{V_o}{R} \end{aligned} \quad (5)$$

III. STATE SPACE REPRESENTATION OF SYSTEM

The quadratic buck boost converter is assumed to be in continuous conduction mode and few assumptions like all the components are ideal are taken into consideration. The converter is analysed in two switching modes, ie. Mode 1 is when the switch is turned ON [DT] and Mode 2 when switch is turned OFF [(1-D)T]. By considering the state space equations in each of these intervals and combining gives the final model representation. The state space model of system can be represented by following state and output equation respectively.

$$\begin{aligned} x' &= Ax + Bu \\ y &= Cx + Du \end{aligned}$$

A. Mode 1

The currents flow through inductors L_1 , L_2 , and L_3 , i.e., i_{L1} , i_{L2} , and i_{L3} are increasing (t_0 to t_1). Eq(2) and Eq(3) can be rearranged as follows:

$$\frac{di_{L1}}{dt} = \frac{V_g}{L_1}, \quad \frac{di_{L2}}{dt} = \frac{V_{c1}}{L_2}, \quad \frac{di_{L3}}{dt} = \frac{V_{c2}}{L_3} - \frac{V_o}{L_3} \quad (6)$$

$$\begin{aligned} \frac{dV_{c1}}{dt} &= \frac{i_{L2}}{C_1}, & \frac{dV_{c2}}{dt} &= \frac{i_{L3}}{C_2}, \\ \frac{dV_o}{dt} &= \frac{i_{L3}}{C_3} - \frac{V_o}{RC_3} \end{aligned} \quad (7)$$

B. Mode 2

Inductor currents i_{L1} , i_{L2} , and i_{L3} are decreasing. Eq(4) and Eq(5) can be rearranged as follows:

$$\frac{di_{L1}}{dt} = \frac{V_g}{L_1} - \frac{V_{c1}}{L_1}, \quad \frac{di_{L2}}{dt} = \frac{-V_{c2}}{L_2}, \quad \frac{di_{L3}}{dt} = \frac{-V_o}{L_3} \quad (8)$$

$$\begin{aligned} \frac{dV_{c1}}{dt} &= \frac{-i_{L1}}{C_1}, & \frac{dV_{c2}}{dt} &= \frac{-i_{L2}}{C_2}, \\ \frac{dV_o}{dt} &= \frac{i_{L3}}{C_3} - \frac{V_o}{RC_3} \end{aligned} \quad (9)$$

Equations for both mode-1 [DT] and mode-2 [(1-D)T] can be combined together for analysis.

Combining eq(4) and eq(7),



$$\frac{di_{L1}}{dt} = \frac{V_g D}{L_1} + \frac{V_g(1-D)}{L_1}$$

$$\frac{di_{L1}}{dt} = \frac{V_g}{L_1} \tag{10}$$

$$\frac{di_{L2}}{dt} = \frac{V_{c1} D}{L_2} + \frac{-V_{c2}(1-D)}{L_2} \tag{11}$$

$$\frac{di_{L3}}{dt} = \frac{V D}{L_3} - \frac{V D}{L_3} + \frac{V}{L_3}(1-D)$$

$$\frac{di_{L3}}{dt} = \frac{V_{c2} D}{L_3} - \frac{V_o}{L_3} \tag{12}$$

Combining eq(5) and eq(7),

$$\frac{di_{V_{c1}}}{dt} = \frac{i_{L2} D}{C_1} + \frac{-i_{L1}(1-D)}{C_1} \tag{13}$$

$$\frac{dV_{c2}}{dt} = \frac{i_{L3} D}{C_2} + \frac{-i_{L2}(1-D)}{C_2} \tag{14}$$

$$\frac{dV_o}{dt} = \frac{i_{L3} D}{C_3} - \frac{V_o D}{RC_3} + \frac{i_{L3}(1-D)}{C_3} - \frac{V_o(1-D)}{RC_3}$$

$$\frac{dV_o}{dt} = \frac{i_{L3}}{C_3} + \frac{-V_o}{RC_3} \tag{15}$$

The above equations can be represented as state space model as shown below in eq(16).

Choose the state variable as $i_{L1} = x_1, i_{L2} = x_2, i_{L3} = x_3, V_{C1} = x_4, V_{C2} = x_5, V_o = V_{C3} = V_{C4} = x_6, u = V_{in}, y = V_o$.

$$\begin{bmatrix} \dot{x}_1 \\ \dot{x}_2 \\ \dot{x}_3 \\ \dot{x}_4 \\ \dot{x}_5 \\ \dot{x}_6 \end{bmatrix} = \begin{bmatrix} 0 & 0 & 0 & \frac{D-1}{L_1} & 0 & 0 \\ 0 & 0 & 0 & \frac{D-1}{L_2} & 0 & 0 \\ 0 & 0 & 0 & \frac{D-1}{L_3} & \frac{-1}{L_3} & 0 \\ \frac{D-1}{C_1} & \frac{D}{C_1} & 0 & 0 & 0 & 0 \\ 0 & \frac{D-1}{C_2} & \frac{D}{C_2} & 0 & 0 & 0 \\ 0 & 0 & \frac{1}{C_3} & 0 & 0 & \frac{-1}{RC_3} \end{bmatrix} \begin{bmatrix} x_1 \\ x_2 \\ x_3 \\ x_4 \\ x_5 \\ x_6 \end{bmatrix} + \begin{bmatrix} \frac{1}{L_1} \\ 0 \\ 0 \\ 0 \\ 0 \\ 0 \end{bmatrix} u$$

$$y = \begin{bmatrix} 0 & 0 & \frac{-1}{L_3} & 0 & 0 & \frac{-1}{RC_3} \end{bmatrix} \begin{bmatrix} x_1 \\ x_2 \\ x_3 \\ x_4 \\ x_5 \\ x_6 \end{bmatrix} \tag{16}$$

IV. CONTROLLER DESIGN

Controller based on fuzzy logic and PI controller based on Tyreus-Luyben were designed for the proposed system.

A. PI controller

In the simple PI controller, the Ziegler-Nichols tuning procedure works quite well, but this method is laborious and time consuming. There are many tuning rules to determine the tuning parameters systematically. However, poorly tuned PI controllers are often found in industry.

One of the keys to overcome this problem is that the tuning rules should be simple and applicable to a wide range of

processes. The methods of Tyreus and Luyben, along with the most accepted PI tuning rule given by Ziegler and Nichols (Z-N), is more conservative approach and provide disturbance less response.

PI controller based on Tyreus Luben(T-L) method was also designed for the system to analyze the controller performance. For TL method calculation, system must be in sustained periodic oscillation and this is obtained when proportional gain is increased to a certain value and this value is called ultimate gain, K_u and time period of one such oscillation obtained is called ultimate period, P_u .

Sustained oscillation for both buck and boost mode is obtained as shown in Fig. 6 and Fig. 7. With these values $K_p=0.31*K_u$ and $K_i=(0.31*K_u) / (2.2*P_u)$ can be found out. The (K_p, K_i) values thus obtained from TL method are (0.2,15) for boost mode and (0.4,30) for buck mode.

B. Fuzzy Logic Controller

A rule based Fuzzy Logic Controller is created for quadratic buck-boost converter as in Fig 6. A FLC has to be created before the system is simulated in the MATLAB/SIMULINK. Using fuzzy logic tool box, a FIS file has to be created in FIS editor. Membership functions needed for this system is selected and accordingly rules were setup for the membership functions for the constant output.

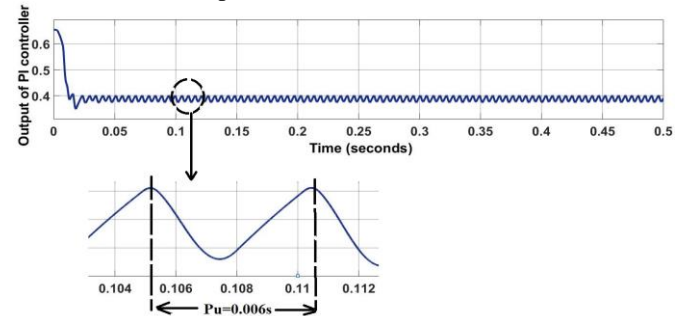

Fig. 6. Output of PI controller with $K_p=0.6$ (Boost Mode)

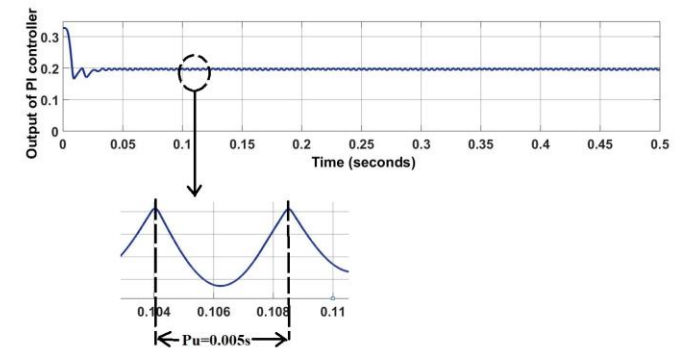

Fig. 7. Output of PI controller with $K_p=1.2$ (Buck Mode)

The fuzzy rules map an input space to an output space by means of a list of IF–THEN statements. There are two input variables each with five linguistic levels, therefore the total number of possible fuzzy rules could be $5 \times 5 = 25$. Table I illustrates the 25 fuzzy rules. The realization of a controller is obtained in the MATLAB/SIMULINK. The membership functions i.e. two inputs, an error(E), change in error(dE) and one output which is duty ratio control(dD) is created and 25 fuzzy rules are determined. Membership functions are shown in Fig. 8, Fig. 9 and Fig. 10.

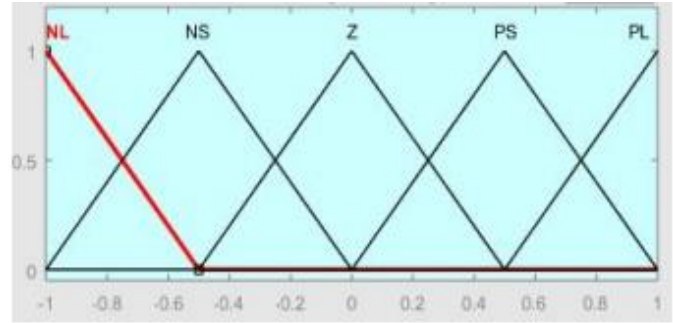

Fig. 11. Output: Duty ratio control

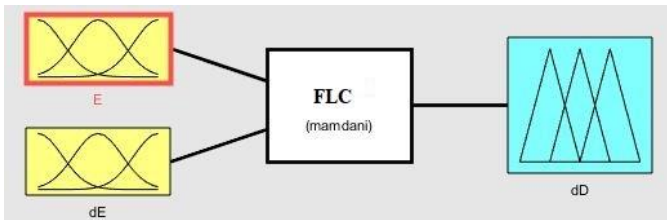

Fig. 8. Membership functions of FLC

TABLE I
FUZZY RULES

E \ dE	NL	NS	Z	PS	PL
NL	NL	NL	NL	NS	Z
NS	NL	NL	NS	Z	PS
Z	NL	NS	Z	PS	PL
PS	NS	Z	PS	PL	PL
PL	Z	PS	PL	PL	PL

In the Table I, NL means Negative Large, NS means Negative Small, Z means Zero, PS means Positive Small and PL means Positive Large. These are the possible variation that may occur in control variables.

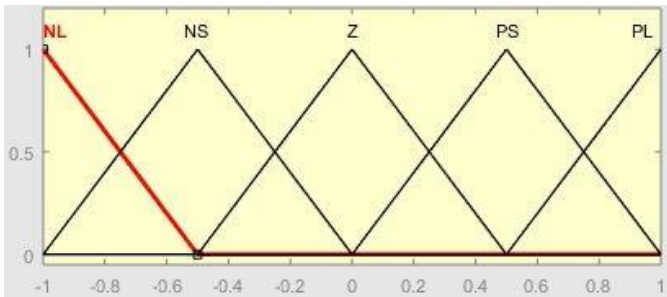

Fig. 9. Input1: Error

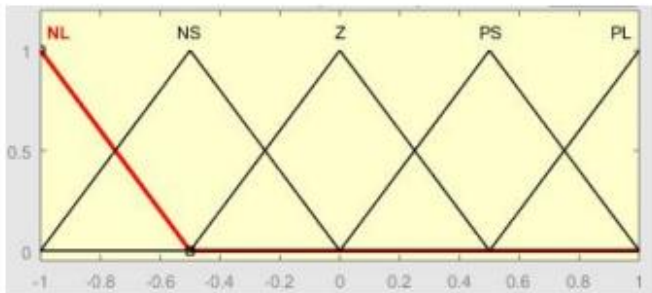

Fig. 10. Input2: Change in error

V. RESULTS AND DISCUSSION

For analysing the proposed system, the simulation model of proposed system is simulated using MATLAB. A FLC is created in FIS editor using a fuzzy logic toolbox. Parameter specifications taken for simulation are listed in the table (Table II).

TABLE II
PARAMETERS

Sl.No.	Components	Symbol	Specifications
1	Input Voltage	V_{in}	25V
2	Output Voltage	V_o	50V
3	Load Resistance	R_1, R_2	40ohm
4	Inductors	L_1	100 μ H
		L_2	400 μ H
		L_3	3mH
5	Capacitors	C_1, C_2	47 μ F
		C_3, C_4	660 μ F
6	Switching frequency	fs	40KHz

A. Open Loop

The converter is first simulated in MATLAB as open loop without the controller to analyse the dual output and inductor currents.

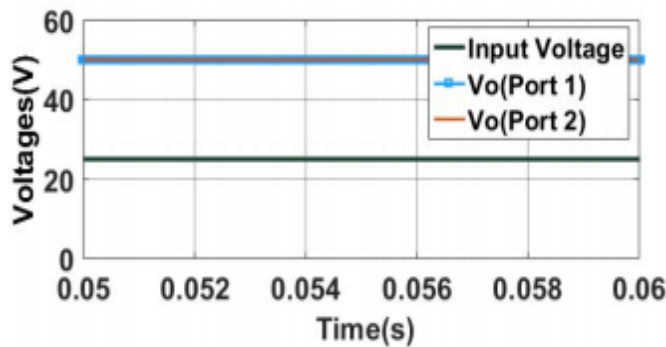

Fig. 12. Input and Output ports voltage

Fig. 12 shows the input and output ports voltage of the converter in open loop. Dual output voltages of 50v is obtained when an input voltage of 25V is applied across the input of the converter.

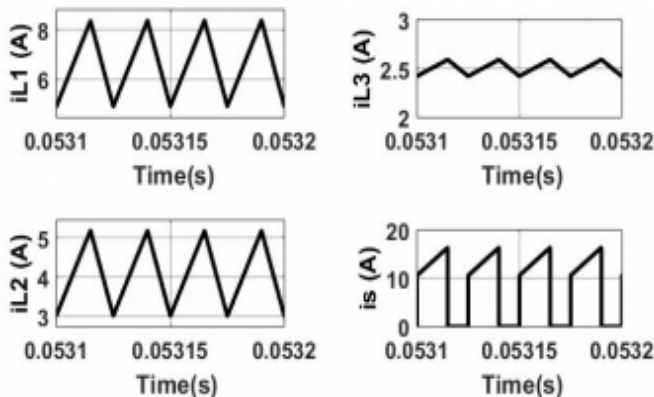

Fig. 13. Inductor currents i_{L1}, i_{L2}, i_{L3} and Switch current i_s

Fig. 13 shows current through inductors. Inductors get charged during T_{on} and get discharged during T_{off} of switch. The current flow through the switch is approximately equal to the sum of the three inductor currents when the switch is turned ON. The proposed converter has continuous input port current and continuous output port current, so they do not require extra inductors and capacitors as input and output filters, to satisfy the EMI/EMC issues in practical applications.

B. Closed Loop

Closed-loop systems are designed to automatically achieve and maintain the desired output condition by comparing it with the actual condition. It does this by generating an error signal, which is the difference between the output and the reference input. In other words, a “closed-loop system” is a fully automatic control system in which its control action being dependent on the output in some way.

Converter was simulated in MATLAB using PI controller and then with fuzzy logic controller to analyse the performance.

Design criterias chosen for controller are $V_o=48V$ for boost mode and $V_o=12V$ for buck mode.

PI and fuzzy logic controller implementation was done in MATLAB. System response are compared for both the controller as shown in Fig. 14. It is evident that the fuzzy logic controller can provide better and faster response compared to PI controller.

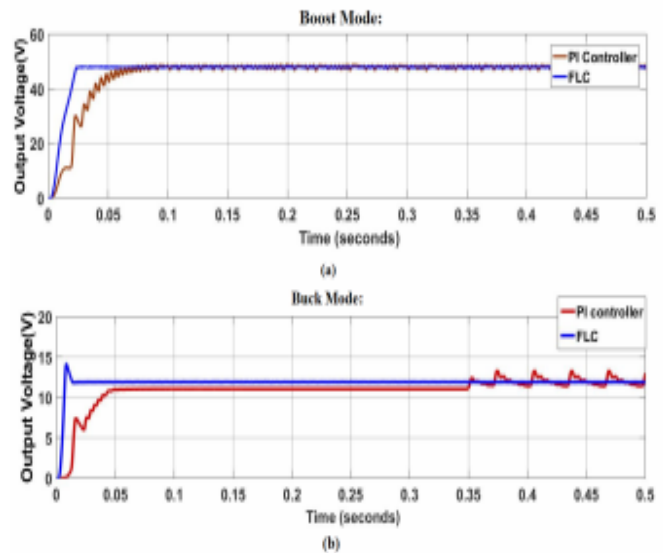

Fig. 14. Comparison of output voltage for PI controller and FLC in (a)boost mode and (b)buck mode

Fig. 15 shows the input and output waveforms with variable irradiance from PV panel in buck mode. Dual output Voltage of 12V is obtained. Even with variable irradiance from PV panel, FLC regulated the output in buck mode without any ripple.

Fig. 16 shows the input and output waveforms with variable irradiance from PV panel in boost mode. Dual output Voltage of 48V is obtained. Even with variable irradiance from PV panel, FLC regulated the output at required value without any ripple.

The performance of fuzzy logic controller is further analysed with the large variation of input voltage. This large variation of input was simulated with help of signal builder in MATLAB. Fig. 17 and Fig. 18 show that the output voltage remains constant as per the design requirements of 48V in boost mode and 12V in buck mode given to the controller respectively.

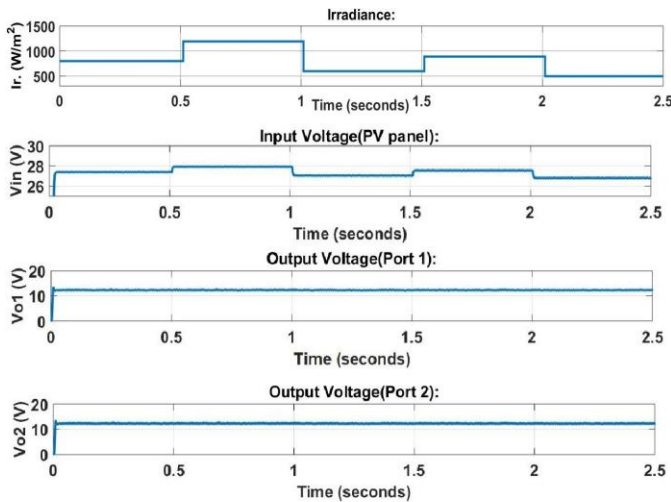

Fig. 15. Input and output waveforms for varying irradiance-Buck Mode

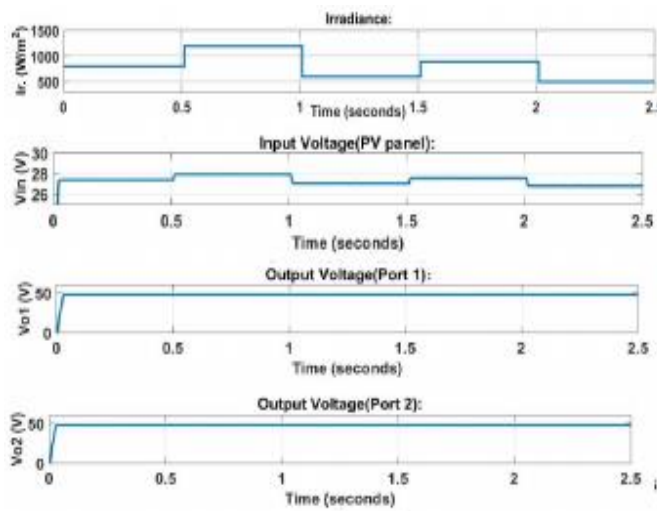

Fig. 16. Input and output waveforms for varying irradiance-Boost Mode

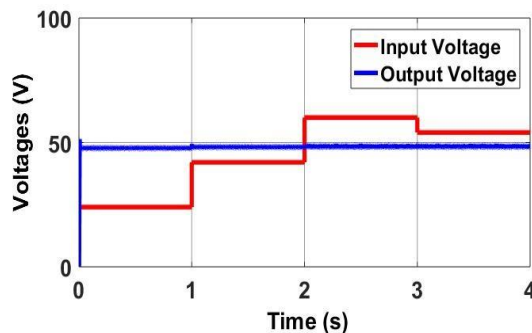

Fig. 17. Input and output waveforms for varying input(Boost Mode) with FLC

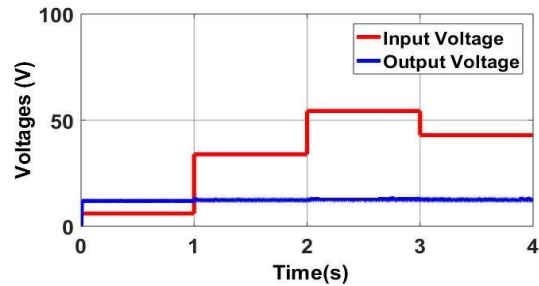

Fig. 18. Input and output waveforms for varying input(Buck Mode) with FLC

VI. PERFORMANCE COMPARISON

The comparison of output voltage for PI controller and FLC in boost mode and buck mode can be seen in Fig. 14. Simulation outcome of proposed converter shows that settling time of PIC in boost mode is 0.07 seconds whereas for FIC it is reduced to 0.03 seconds, similarly in buck mode in PIC it is 0.05 seconds and in FLC its reduced to 0.01 seconds where fuzzy logic control performance is greatly improved. And also ripple amount in output voltage is comparatively more in PIC than FLC in boost mode. Eventhough output is well regulated till 0.35s in buck mode for PIC, it looses its stable output after 0.35s which may affect overall system. This controller performance comparison is shown in Table III.

TABLE III
CONTROLLER PERFORMANCE COMPARISON

Factors		PI CONTROLLER (TL method)	FLC
Settling Time	Buck mode	0.05s	0.01s
	Boost mode	0.07s	0.03s
Disturbance in output	Buck mode	Yes	No
	Boost mode	Yes	No

Fig. 19 shows the comparison of output ripple in existing[Fig. 2] and proposed converter topology. The ripples present in the output voltage is less than 1% in the proposed system.

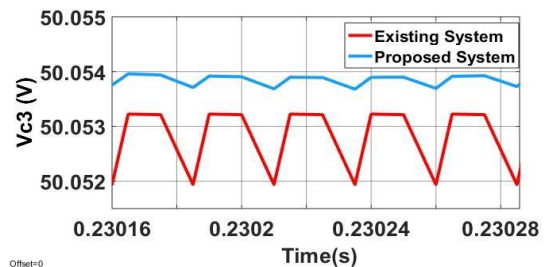

Fig. 19. Comparison of output ripple in existing and proposed converter topology



TABLE IV
TOPOLOGY COMPARISON

Factors	Existing system	Proposed system
Dual output	No	Yes
Output voltage ripple	1.2mV	0.4mV
Controller	No	Yes

Table IV shows the comparison of the proposed topology of converter with the existing topology of converter. With the dual output voltage, there is an added advantage of reduced voltage ripple.

VII. CONCLUSION

Dual output quadratic buck boost converter offers a wide range of conversion ratio and uniform current sharing with an added advantage of reduced output ripple. The proposed converter has an inductor in the input port as well as an inductor in the output port, which is capable of making the input port current and output port current to be continuous and contributes to the simplification of the design of input and output filters. The circuit is simulated in MATLAB/SIMULINK software to substantiate the circuit function. The conventional control i.e. Proportional-Integral (PI) controller is differentiated from smart/intelligent fuzzy logic controller (FLC) in both buck-boost mode. Simulation outcome and investigation of proposed converter shows that settling time of PIC in boost mode is 0.07 seconds whereas the for FLC it is reduced to 0.03 seconds, similarly in buck mode in PIC it is 0.05 seconds and in FIC it is reduced to 0.01seconds, where fuzzy logic control performance is greatly improved and superior as shown in the Table III.

VIII. REFERENCES

[1] Zhang, Neng, Guidong Zhang, K. See and B. Zhang, "A Single-Switch Quadratic Buck-Boost Converter With Continuous Input Port Current and Continuous Output Port Current. (2012)", *IEEE Transactions on Power Electronics*, vol.33 , no.5, (pp. 4157-4166).

[2] G. Moschopoulos, "Quadratic power conversion for industrial applications(2010)", *in proceedings of 25th Annual IEEE Applied Power Electronics Conference Exposition*, (pp. 1320-1327).

[3] X. L. Wei, K. M. Tsang, and W. L. Chan, "Non-linear PWM control of single-switch quadratic buck converters using internal model(2009)", *IET Power Electronics*, vol. 2, no. 5, (pp. 475-483).

[4] J. A. M. Saldana, J. L. Ramos, E. E. C. Gutierrez, and M. G. O. Lopez, "Average current-mode control scheme for a quadratic buck converter with a single switch(2012)", *IEEE Transactions on Power Electronics*, vol. 23, no. 1, (pp. 485-490).

[5] J. J. Chen, B. H. Huang, C. M. Kung, W. Y. Tai, and Y. S. Hwang, "A new single-inductor quadratic buck converter using average-currentmode control without slope-compensation(2010)", *in proceedings of 5th IEEE*

Conference of Industrial Electronics Applied, (pp. 1082-1087).

[6] J.A.M. Saldana, R. L. Palomo, and E. P. Hernandez, "Parameters selection criteria of proportional-integral controller for a quadratic buck converter(2014)", *IET Power Electronics*, vol. 7, no. 6, (pp. 1527-1535).

[7] A. Ayachit and M. K. Kazimierczuk, "Open-loop small signal transfer functions of the quadratic buck PWM DC-DC converter in CCM(2014)", *in proceedings of 40th Annual Conference IEEE Industrial Electronics*, (pp. 1643-1649).

[8] J. L. Ramos, M. G. O. Lopez, L. H. D. Saldierna, and J. A. M. Saldana, "Switching regulator using a quadratic boost converter for wide DC conversion ratios(2009)", *IET Power Electronics*, vol. 2, no. 5, (pp. 605-613).

[9] J. A. M. Saldana, R. L. Palomo, E. P. Hernandez, and J. L. G. Martinez, "Modelling and control of a DC-DC quadratic boost converter(2014)", *IET Power Electronics*, vol. 7, no. 1, (pp. 11-22).

[10] Polanco, "Robust sliding-mode control design for a voltage regulated quadratic boost converter(2015)", *IEEE Transactions of Power Electronics*, vol. 30, no. 4, pp. 2313-2327.

[11] M. A. A. Saffar, E. H. Ismail, and A. J. Sabzali, "High efficiency quadratic boost converter(2012)", *in proceedings of 27th Annual IEEE Applied Power Electronics Conference*, (pp. 1245-1265).

[12] Pedro Mart'ın Garc'ia-Vite; Julio C. Rosas-Caro , Ana Lidia Mart'inezSalazar , "Quadratic buck-boost converter with reduced input current ripple and wide conversion range(2019)", *IET Power Electronics*, vol. 12, No. 15, (pp. 3977-3986).

[13] Vitor Fernˆao Pires , Senior Member, IEEE, Daniel Foito, and Armando Cordeiro "A DC-DC Converter With Quadratic Gain and Bidirectional Capability for Batteries/Supercapacitors(1989)" ,*IEEE Transactions on Industry Applications*, vol. 54, no. 1, (pp. 274-285).

[14] S. Miao, F. Wang, X. Ma, "A new transformerless buck-boost converter with positive output voltage(2016)", *IEEE Transactions on Industrial Electronics* , vol. 63, no. 5, pp. 2965 - 2975.

[15] V. M.. Pacheco, A. J. D. Nascimento, V. J. Farias, "A quadratic buck converter with lossless commutation(2000)", *IEEE Transaction on Industrial Electronics*, vol. 47, no. 2,(pp. 264 - 272).

[16] D. Maksimovic and S. Cuk, "General properties and synthesis of PWM DC-to-DC converters(1989)", *in proceedings of IEEE Power Electronics Conference*, (pp. 515-525).

[17] D. Maksimovic and S. Cuk, "Switching converters with wide DC conversion range(1991)", *IEEE Transaction of Power Electronics*, vol. 6, no. 1, (pp. 151-157).



- [18] Hamid Behjati, Ali Davaudi, "A multiple input multiple output DC-DC converter(2013) ," *IEEE Transaction on Industry Applications* , Vol. 49, No. 3, (pp. 445 - 453).

IJEAST

INTERNATIONAL JOURNAL
OF ENGINEERING APPLIED SCIENCE
AND TECHNOLOGY

ABOUT IJEAST

International Journal of Engineering Applied Science and Technology (IJEAST) is a peer-reviewed, open access journal that publishes high-quality research papers in the field of Engineering, Applied Science and Technology.

IJEAST aims to provide a platform for researchers, academicians, and professionals to share their innovative ideas, research findings, and practical experiences with the global scientific community.

FOCUS AREAS

- Engineering
- Applied Science
- Technology
- Innovation & Development
- Interdisciplinary Studies



PEER REVIEWED

All submissions are rigorously peer reviewed to ensure quality.



OPEN ACCESS

Free and unrestricted access to research for all.



GLOBAL REACH

Connecting researchers and professionals worldwide.



TIMELY PUBLICATION

We ensure a swift and efficient publication process.



For more information, visit our website
www.ijeast.com



INTERNATIONAL JOURNAL
OF ENGINEERING APPLIED SCIENCE
AND TECHNOLOGY

✉ editor@ijeast.com

🌐 www.ijeast.com

📍 India



2455-2143