



IJEAST

INTERNATIONAL JOURNAL
OF ENGINEERING APPLIED SCIENCE
AND TECHNOLOGY



VOLUME : 4 ISSUE : 06 Print / Issue Publication Date: 06-Dec-2019



ISSN : 2455-2143



DOI : 10.33564/IJEAST.2019.v04i06.033

Indexed In



WWW.IJEAST.COM

editor@ijeast.com



CAMERA CALIBRATION USING A 3D TRANSFORMATION MATHEMATICAL MODEL

Abdouslam M. Bashir Author
Department of Mechatronics
Higher Institute of Industrial Technology
Tripoli-Libya

Abstract— This paper presents a mathematical model for video sequence calibration when a standard camera is mounted on a five degree-of-freedom fixture. A 3D transformation was used in order to establish the absolute position and orientation of the camera. In this approach, it has been assumed that the bottom left hand corner of the left wall is the origin (0,0,0). This origin was selected because WTK coordinate system adopts a right-hand coordinate frame as stated in Sense8 Inc. literature (1999). The Y coordinate has been inverted to match with that of the static camera. A respectable registration between the real and virtual scenes was achieved in an augmented reality scene following the calibration. The transformation of the camcorder coordinates was used to set up the virtual sense, although minor dynamic errors were found.

Keywords— calibration, mathematical transformation.

I. INTRODUCTION

It is clear in 3D computer vision, camera calibration is a necessary step to extract metric

information from 2D images. Extensive studies have been carried away over the years in computer vision and photogrammetry with various techniques being proposed. In this chapter, we review the techniques proposed in the literature include those using 3D apparatus (two or three planes orthogonal to each other, or a plane undergoing a pure translation, etc.), 2D objects (planar patterns undergoing unknown motions), 1D objects (wand with dots) and unknown scene points in the environment (self-calibration).

Tsai created a popular technique for three-dimensional (3D) camera calibration for machine vision metrology using off-the-shelf TV cameras and lenses is described by Roge (1987).

The two-stage technique has advantage in terms of accuracy, speed, and versatility over existing state of the art. Dias (2003) argued that results from the technique though showed that the two-stage calibration could be done in real time with it could be achieved with slight modification.

Alvarez, et al. (2012) designed several mathematical models for video sequence calibration as cameras are mounted on a tripod. The calibration, in this method, was based on the geometry of the tripod and a primitive tracking procedure which uses lines and circles as primitive. A Classification and Regression Tree (CART) was used for the extraction of primitive information. The quality of the camera calibration procedure was examined by inserting virtual elements in the video sequence.

An interesting method made by Vasconcelos et al. (2012) which a minimal algorithm for fully calibrating a camera from 11 independent pairwise point correspondences with two other calibrated cameras.

The proposed algorithm could be used to insert or re-calibrate a new camera into an existing network, without having to interrupt operation. However, Bazargani (2015) provided an extensive review of some techniques proposed in the literature on camera calibration techniques including involving camera pose estimation and distance estimation.

II. CAMERA CALIBRATION

The position and orientation of the camera has to be known in order to have both real and virtual worlds aligned. A mounting fixture was made to constrain the five degree-of-freedom camera body (X, Y, Z, pitch, yaw), as shown in figures 1 and 2.

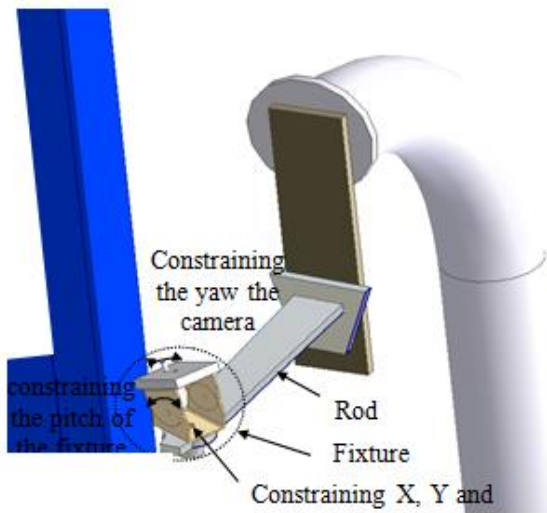

Fig. 1. Camera alignment with the mounting component

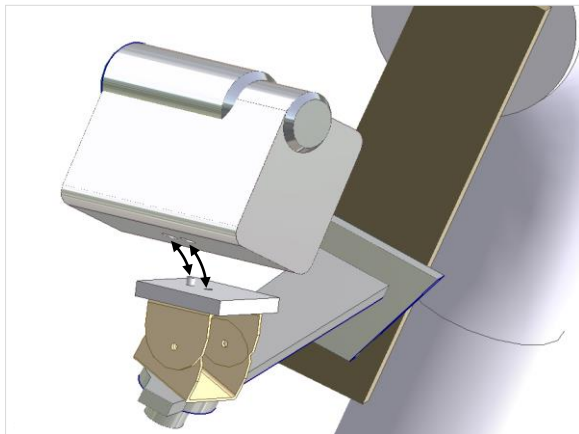

Fig. 2. Attaching the camera to the fixture

To establish the absolute position and orientation of the camera, a 3D transformation was used. In this method it has been assumed that the bottom left hand corner of the left wall is the origin (0,0,0). This origin was selected because Word Tool Kit coordinate system adopts a right-hand coordinate frame as stated in Sense8 Inc. (1999). The Y coordinate has been inverted to match with that of the static camera.

WTK supports 4x4 homogeneous transformation matrices, which represent translation, scaling and rotation in 3D space. Points are given a fourth coordinate W ($W \neq 0$), whereby each

point in 3-space is represented by a line and expressed as (X, Y, Z, W) or (X/W, Y/W, Z/W, 1). The transformation of a given point in 3D space as a subspace of 4D space, which is given by dividing X, Y and Z by W (where $W = 1$), is known as homogenisation as described Foley et al. (1994).

Translation T (d_x, d_y, d_z) of a point in 3D space is carried out using the 4x4 matrix

$$T(d_x, d_y, d_z) = \begin{bmatrix} 1 & 0 & 0 & d_x \\ 0 & 1 & 0 & d_y \\ 0 & 0 & 1 & d_z \\ 0 & 0 & 0 & 1 \end{bmatrix} \quad 1$$

Scaling S (s_x, s_y, s_z) of a point can be expressed similarly as

$$S(s_x, s_y, s_z) = \begin{bmatrix} s_x & 0 & 0 & 0 \\ 0 & s_y & 0 & 0 \\ 0 & 0 & s_z & 0 \\ 0 & 0 & 0 & 1 \end{bmatrix} \quad 2$$

The **rotation** in 3D space can be performed using the following 3 equations:

$$R_x(\theta) = \begin{bmatrix} 1 & 0 & 0 & 0 \\ 0 & \cos\theta & -\sin\theta & 0 \\ 0 & \sin\theta & \cos\theta & 0 \\ 0 & 0 & 0 & 1 \end{bmatrix} \quad 3$$

$$R_y(\theta) = \begin{bmatrix} \cos\theta & 0 & \sin\theta & 0 \\ 0 & 1 & 0 & 0 \\ -\sin\theta & 0 & \cos\theta & 0 \\ 0 & 0 & 0 & 1 \end{bmatrix} \quad 4$$

and

$$R_z(\theta) = \begin{bmatrix} \cos\theta & -\sin\theta & 0 & 0 \\ \sin\theta & \cos\theta & 0 & 0 \\ 0 & 0 & 1 & 0 \\ 0 & 0 & 0 & 1 \end{bmatrix} \quad 5$$

where θ the angle of rotation.

The dimensions of the camcorder are (73x100x146mm) as shown in figure 3.

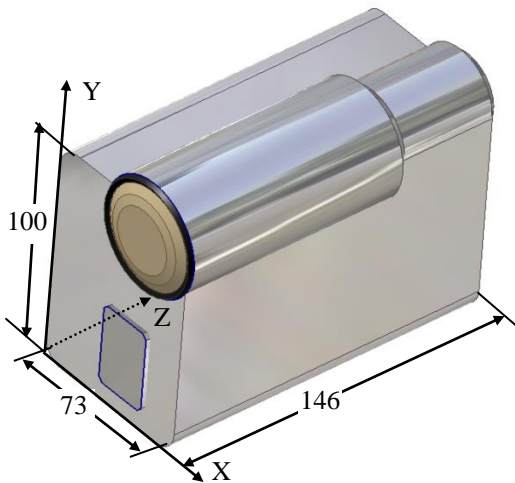

Fig. 3. The camcorder coordinate system and physical dimensions

The camera location, in terms of the 3 primitive transformations (T, Rx, and Ry) are required to be composed, which involves the 3 points (P_1 , P_2 and P_3) being defined as the camera's extents (see figure 4). Since the frame and the fixture are co-incident on the same angle around the Z axis, Rz need be considered.

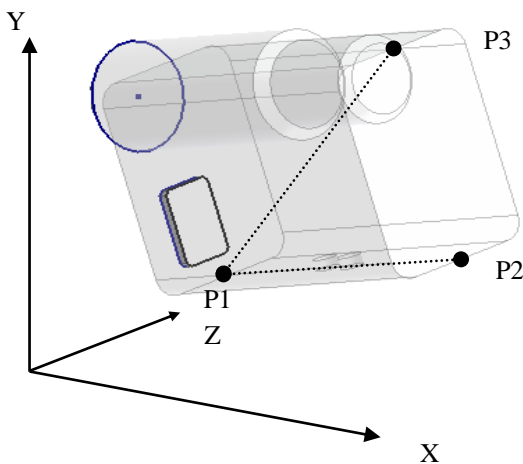

Fig. 4. Defining points on the camcorder body

The procedure was performed in three steps illustrated by Foley et al. (1994), as follows:

Step 1. Translate P_1 to the origin.

Using the translation

$$T(-x_1, -y_1, -z_1) = \begin{bmatrix} 1 & 0 & 0 & -x_1 \\ 0 & 1 & 0 & -y_1 \\ 0 & 0 & 1 & -z_1 \\ 0 & 0 & 0 & 1 \end{bmatrix} \quad (6)$$

Applying T to P_1 , P_2 and P_3 gives

$$P'_1 = T(-x_1, -y_1, -z_1) \cdot P_1 = \begin{bmatrix} 0 \\ 0 \\ 0 \\ 1 \end{bmatrix} \quad (7)$$

$$P'_2 = T(-x_1, -y_1, -z_1) \cdot P_2 = \begin{bmatrix} x_2 - x_1 \\ y_2 - y_1 \\ z_2 - z_1 \\ 1 \end{bmatrix} \quad (8)$$

$$P'_3 = T(-x_1, -y_1, -z_1) \cdot P_3 = \begin{bmatrix} x_3 - x_1 \\ y_3 - y_1 \\ z_3 - z_1 \\ 1 \end{bmatrix} \quad (9)$$

Step 2: Rotate about the Y-axis: (figure 5 shows P_1P_2 after step 1), along with the projection of P_1P_2 onto the XZ plane. The angle of rotation is $-(90 - \theta) = \theta - 90$. Then

$$\cos(\theta - 90) = \sin \theta = \frac{z'_2}{D_1} = \frac{z_2 - z_1}{z_1} \quad (10)$$

$$\sin(\theta - 90) = -\cos \theta = -\frac{x'_2}{D_1} = -\frac{x_2 - x_1}{D_1} \quad (11)$$

$$D_1 = \sqrt{(z'_2)^2 + (x'_2)^2} = \sqrt{(z_2 - z_1)^2 + (x_2 - x_1)^2} \quad (12)$$

Where the values are substituted into equation 4

$$P''_2 = R_y(\theta - 90) \cdot P'_2 \quad (13)$$

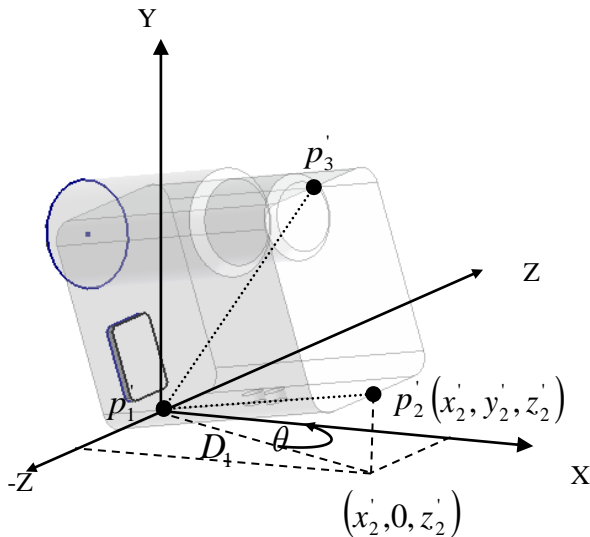

Figure 5 Camcorder translation after translating P1 to origin

Step 3: Rotate about the X-axis. (figure 6 shows P_1P_2

after step 2). The angle of rotation is ϕ , for which

$$\cos \phi = \frac{z_2''}{D_2}, \quad \sin \phi = \frac{x_2''}{D_2} \quad 14$$

Where $D_2 = |P_1''P_2''|$, The length of $P_1''P_2''$. The length of

line $P_1''P_2''$ is the same as the length of line P_1P_2 , since the rotation and translation transformations preserve length, so

$$D_2 = |P_1''P_2''| = |P_1P_2| = \sqrt{(x_2 - x_1)^2 + (y_2 - y_1)^2 + (z_2 - z_1)^2} \quad 15$$

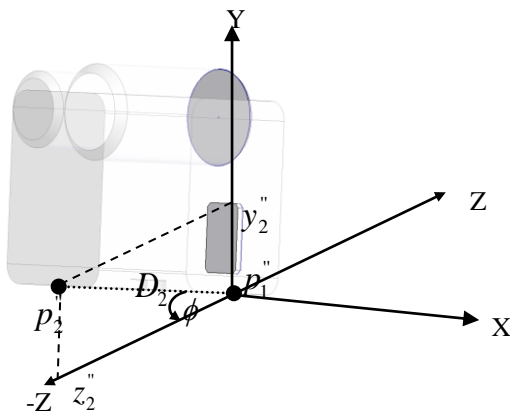

The result of rotation in step 3 is

$$P_2'' = R_x(\phi) \cdot P_2' = R_x(\phi) \cdot R_y(\theta - 90) \cdot P_2 = R_x(\phi) \cdot R_y(\theta - 90) \cdot T \cdot P_2 \quad 16$$

Figure 6 Camcorder rotation about x-axis

The following example is an implementation of the 3 primitive transformations on the actual static camcorder (all values are based on AutoCAD 2000 outputs, and are in mm).

Step 1.

$$P_1 = (1253.85, 394.39, -279.44). \quad 17$$

$$P_2 = (1359.97, 424.74, -361.08). \quad 18$$

$$P_3 = (1340.13, 522.56, -375). \quad 19$$

Applying T to P_1 , P_2 and P_3 gives

$$P_1' = T(-x_1, -y_1, -z_1) \cdot P_1 = \begin{bmatrix} 1 & 0 & 0 & -1235.85 \\ 0 & 1 & 0 & -394.39 \\ 0 & 0 & 1 & 279.44 \\ 0 & 0 & 0 & 1 \end{bmatrix} \cdot \begin{bmatrix} 1235.85 \\ 394.39 \\ -279.44 \\ 1 \end{bmatrix} = \begin{bmatrix} 0 \\ 0 \\ 0 \\ 1 \end{bmatrix} \quad 5.20$$

$$P_2' = T(-x_1, -y_1, -z_1) \cdot P_2 = \begin{bmatrix} 1 & 0 & 0 & -1235.85 \\ 0 & 1 & 0 & -394.39 \\ 0 & 0 & 1 & 279.44 \\ 0 & 0 & 0 & 1 \end{bmatrix} \cdot \begin{bmatrix} 1359.97 \\ 424.74 \\ -361.06 \\ 1 \end{bmatrix} = \begin{bmatrix} 106.12 \\ 30.35 \\ -81.64 \\ 1 \end{bmatrix}, \quad 5.21$$

$$P_3' = T(-x_1, -y_1, -z_1) \cdot P_3 = \begin{bmatrix} 1 & 0 & 0 & -1235.85 \\ 0 & 1 & 0 & -394.39 \\ 0 & 0 & 1 & 279.44 \\ 0 & 0 & 0 & 1 \end{bmatrix} \cdot \begin{bmatrix} 1340.13 \\ 522.56 \\ -375 \\ 1 \end{bmatrix} = \begin{bmatrix} 86.28 \\ 128.17 \\ -95.56 \\ 1 \end{bmatrix}, \quad 22$$

Step 2: rotate about the Y-axis is given as

$$D_1 = \sqrt{(81.64)^2 + (106.12)^2} = 133.89. \quad 23$$

So,

$$\sin \theta = \frac{-81.64}{144.89} = -0.60, \quad -\cos \theta = \frac{106.12}{133.89} = -0.79. \quad 24$$

Thus,

$$\theta = -37.57. \quad 25$$

$$P_2'' = R_y(\theta - 90) \cdot P_2'. \quad 26$$



$$R_y(\theta-90) = \begin{bmatrix} \cos(\theta-90) & 0 & \sin(\theta-90) & 0 \\ 0 & 1 & 0 & 0 \\ -\sin(\theta-90) & 0 & \cos(\theta-90) & 0 \\ 0 & 0 & 0 & 1 \end{bmatrix} = \begin{bmatrix} \sin\theta & 0 & -\cos\theta & 0 \\ 0 & 1 & 0 & 0 \\ \cos\theta & 0 & \sin\theta & 0 \\ 0 & 0 & 0 & 1 \end{bmatrix}$$

$$= \begin{bmatrix} -0.60 & 0 & -0.79 & 0 \\ 0 & 1 & 0 & 0 \\ 0.79 & 0 & -0.60 & 0 \\ 0 & 0 & 0 & 1 \end{bmatrix} .$$

27

So,

$$P_2'' = \begin{bmatrix} -0.60 & 0 & -0.79 & 0 \\ 0 & 1 & 0 & 0 \\ 0.79 & 0 & -0.60 & 0 \\ 0 & 0 & 0 & 1 \end{bmatrix} \cdot \begin{bmatrix} 106.12 \\ 30.35 \\ -81.64 \\ 1 \end{bmatrix} = \begin{bmatrix} 0 \\ 30.35 \\ 133.89 \\ 1 \end{bmatrix}$$

$$\text{Or } [0 \quad y_2 - y_1 \quad D \quad 1]^T \quad 28$$

As expected, the X component of P_2'' is zero, and the Z component is the length D1.

Step 3: Rotate about the X-axis.

$$D_2 = \sqrt{(106.12)^2 + (30.35)^2 + (-81.64)^2} = 137.28 . \quad 29$$

The result of rotation in step 3 is

$$P_2''' = [x_2'' \quad y_2'' \quad z_2'' \quad 1]^T = P_2'' = [0 \quad 30.35 \quad 133.89 \quad 1]^T . \quad 30$$

$$\cos\phi = \frac{133.89}{137.28} = 0.79 . \quad 31$$

$$\sin\phi = \frac{30.35}{137.28} = 0.22 . \quad 32$$

Thus $\phi = 12.77$.

$$P_2''' = R_x(\phi) \cdot P_2'' = R_x(\phi) \cdot R_y(\theta-90) \cdot P_2' = R_x(\phi) \cdot R_y(\theta-90) \cdot T \cdot P_2 . \quad 33$$

$$R_x(\phi) = \begin{bmatrix} 1 & 0 & 0 & 0 \\ 0 & \cos\phi & -\sin\phi & 0 \\ 0 & \sin\phi & \cos\phi & 0 \\ 0 & 0 & 0 & 1 \end{bmatrix} = \begin{bmatrix} 1 & 0 & 0 & 0 \\ 0 & 0.97 & -0.22 & 0 \\ 0 & 0.22 & 0.97 & 0 \\ 0 & 0 & 0 & 1 \end{bmatrix} . \quad 34$$

So,

$$P_2''' = \begin{bmatrix} 1 & 0 & 0 & 0 \\ 0 & 0.97 & -0.22 & 0 \\ 0 & 0.22 & 0.97 & 0 \\ 0 & 0 & 0 & 1 \end{bmatrix} \cdot \begin{bmatrix} -0.60 & 0 & -0.97 & 0 \\ 0 & 1 & 0 & 0 \\ 0.79 & 0 & -0.60 & 0 \\ 0 & 0 & 0 & 1 \end{bmatrix} \cdot \begin{bmatrix} 106.12 \\ 30.35 \\ -81.64 \\ 1 \end{bmatrix}$$

$$= \begin{bmatrix} 1 & 0 & 0 & 0 \\ 0 & 0.97 & -0.22 & 0 \\ 0 & 0.22 & 0.97 & 0 \\ 0 & 0 & 0 & 1 \end{bmatrix} \cdot \begin{bmatrix} 0 \\ 30.35 \\ 133.89 \\ 1 \end{bmatrix} = \begin{bmatrix} 0 \\ 0 \\ 137.89 \\ 1 \end{bmatrix} \text{ or}$$

$$[0 \quad 0 \quad |P_1 P_2| \quad 1]^T . \quad 35$$

As can be seen, $P_1'' P_2''$ is rotated into the Z-axis by (ϕ) .

The line segment $P_1'' P_3''$ is not shown because it is not used to determine the angle of rotation.

III. CONCLUSION

A standard camera on a five degree-of-freedom fixture was used to feed video shots. A 3D transformation was used in order to calculate the absolute position and orientation of the camera. Good registration between the real and virtual scenes was achieved in the camera calibration. The transformation of the camcorder coordinates was used to set up the virtual sense, although minor dynamic errors were found.

III. ACKNOWLEDGMENT

The effort of the High Institute of Industrial Technology-Libya is highly appreciated, for their unlimited support.

IV. REFERENCES

- [1] Alvarez, L, Henríquez, P., Mazorra, L., (2012), Mathematical Models for the Calibration of Cameras Mounted on a Tripod Using Primitive Tracking, 9th International Conference, ICIAR 2012, Aveiro, Portugal, Proceedings, Part I, Springer Berlin Heidelberg.(pp 304-311).
- [2] Bazargani , H. (2015) Camera calibration and pose estimation from planes, IEEE Instrumentation & Measurement Magazine, Volume: 18, Issue: 6.
- [3] Dias, P.(2003), Tsai Camera Calibration, Institute of Electronics and Informatics Engineering of Aveiro IEETA, Portugal.
- [4] Foley J., Dam, A., Feiner, S., Hughes, J. and Phillips, R. (1994). Introduction to Computer Graphics, Wesley Publishing Company, Inc. USA



- [5] Roger T. (1987). A Versatile Camera Calibration Technique for HighAccuracy 3D Machine Vision Metrology Using Off-the-Shelf TV Cameras and Lenses,” IEEE Journal of Robotics and Automation, Vol. RA-3, No. 4, (pp. 323–344).
- [6] Sense8 Inc. (1999). NASA combines EAI and the Mathworks products to create a revolutionary space shuttle/space station docking simulation.
- [7] Tsai, R., (2003) A versatile camera calibration technique for high-accuracy 3D machine vision metrology using off-the-shelf TV cameras and lenses, IEEE Journal on Robotics and Automation, USA, (pp. 323 – 344).
- [8] Vasconcelos F., Barreto, J, Boyer, E. (2012) A Minimal Solution for Camera Calibration Using Independent Pairwise Correspondences, European Conference on Computer Vision, (pp.724-737).

IJEAST

INTERNATIONAL JOURNAL
OF ENGINEERING APPLIED SCIENCE
AND TECHNOLOGY

ABOUT IJEAST

International Journal of Engineering Applied Science and Technology (IJEAST) is a peer-reviewed, open access journal that publishes high-quality research papers in the field of Engineering, Applied Science and Technology.

IJEAST aims to provide a platform for researchers, academicians, and professionals to share their innovative ideas, research findings, and practical experiences with the global scientific community.

FOCUS AREAS

- Engineering
- Applied Science
- Technology
- Innovation & Development
- Interdisciplinary Studies



PEER REVIEWED

All submissions are rigorously peer reviewed to ensure quality.



OPEN ACCESS

Free and unrestricted access to research for all.



GLOBAL REACH

Connecting researchers and professionals worldwide.



TIMELY PUBLICATION

We ensure a swift and efficient publication process.



For more information, visit our website

www.ijeast.com



INTERNATIONAL JOURNAL
OF ENGINEERING APPLIED SCIENCE
AND TECHNOLOGY

✉ editor@ijeast.com

🌐 www.ijeast.com

📍 India



2455-2143