



# IJEAST

INTERNATIONAL JOURNAL  
OF ENGINEERING APPLIED SCIENCE  
AND TECHNOLOGY



**VOLUME : 5    ISSUE : 1    Print / Issue Publication Date: 13-Jul-2020**



**ISSN : 2455-2143**



**DOI : 10.33564/IJEAST.2020.v05i01.003**

Indexed In



[WWW.IJEAST.COM](http://WWW.IJEAST.COM)

[editor@ijeast.com](mailto:editor@ijeast.com)



# SMART GARBAGE BIN MONITORING WITH SMS FEEDBACK

Lawal Ahmad Shehu, Kabiru Ibrahim Jahun, Usman Saleh Toro, Nasiru Abdulsalam, Muhammad Shazali Dauda  
Department of Computer and Communications Engineering  
Abubakar Tafawa Balewa University  
Bauchi, Nigeria

**Abstract**—A waste bin is a bin used for household or office waste. A waste bin increases the rate at which human contact infections due to the direct contact with them by users. One of the main concerns with our environment has been solid waste management which impacts the health and environment of our society. The detection, monitoring and management of waste is one of the primary problems of the present era. The traditional way of manually monitoring the wastes in waste bins is a cumbersome process and utilizes more human effort, time and cost which can easily be avoided with our present technologies. This paper presents a solution, in which waste management is automated. The method used in this project is a microcontroller based which includes; the Atmega328 used for timing and controlling the opening and closing the lid of waste bin automatically, the microcontroller which is used alongside with the ultrasonic sensor and a dc motor to achieve an automatic opening of the lid when the user approaches 15cm towards the bin and closes automatically when the user moves 15cm away from the bin. An SMS (Short Message Service) will be sent to the authorized individual when the content in the bin reaches its maximum. The project also uses level indicator to communicate with the authorized personnel on the level of garbage in the bin at certain thresholds.

**Keywords**— Ultrasonic sensor; Liquid Crystal Display; Arduino Board; Global System for Mobile communication (GSM).

## I. INTRODUCTION

The concept of smart city is being deployed in the developing countries. Smart cities possess a sustainable and hygienic environment for a decent quality of life. Here, garbage disposal plays a vital role. By keeping this in mind a smart dustbin is designed to automatically alert the municipality when the dustbin gets filled.

An embedded system is designed in such a way that it avoids the overflow of the dustbin by sending alerts to the municipality with help of a microcontroller linked with GSM module.

Management of Municipal Solid Waste (MSW) is one of the most critical environmental challenges. A lot of polluting sources like haze, emissions are generated from the indiscriminate dumping of MSW. MSW includes household's

refusal and solid wastes generated from industrial, commercial and institutional establishments such as hospitals, markets, streets and industry etc. Now-a-days with the increase of population of a country and its rapid growth of urbanization and industrialization, the cumulative volume of MSW and its appropriate management have become more acute to ensure green environment (Ali, 2012) (Yoda, 2014) (Wang, 2009). Bad waste management can easily result in air pollution and soil contamination. They have an adverse effect on human health. It is learnt from the primary survey done in Guwahati, a city in Assam that garbage accumulation causes 41% of the air pollution Gogoi (2012). They cause air pollution which generally leads to various respiratory problems like COPD, asthma etc. Breeding of mosquitoes and houseflies occur mainly in garbage which are major cause for various diseases like malaria, dengue etc. This also causes headache, nauseous sensation and increase in the stress level. A city with poor sanitation and smelly environment can never be a healthy place to live in. There are about 235 million people currently suffering from asthma for which foul smelling of garbage is also a vital reason Twinkle (2015).

In the conventional approach, a number of trucks from the municipal authority are sent to the waste bins to collect the solid waste. The wastes are loaded in the truck and then transported and transferred to the pre-specified locations. However, the category of the people involved in collecting and transporting the wastes are usually not responsible enough to make the job well done. Very often the wastes are not collected from each and every waste bin properly due to driver's attitude and fatigue Ali, (2012). Recent works have looked at how to solve this problem using smart garbage monitoring Shinde et.al. (2017).

Implementation of this smart dustbin can prevent lumping of the garbage for a longer period of time thereby preventing the widespread of diseases to a great extent and promising a clean environment in the city Twinkle (2015).

## II. RELATED WORK

An automatic waste bin was designed and constructed by Zarith (2010). The project was built around a gear system. The drawback of this project was the absence of an alarm to indicate if the dustbin is filled up for disposal.

An automatic dustbin for office use only was developed by Ajiboye (2015). The project was only limited to opening and closing of lid without an alarm for indication when it is filled up for disposal.

An automatic dustbin with an alarm system was constructed by Khalil (2015). The basic limitation in this design was the absence of a back-up battery when the system is out of supply from the mains. In Chaware et.al. (2017), an IOT based smart garbage monitoring was presented. Though the system provide real time online monitoring, the garbage information is sent to a webpage. This is not feasible as some phones cannot access the internet. In Rohan et.al. (2019), a GPS based garbage monitoring system is proposed. But GPS signals suffer when they are placed in remote indoor environments. Anitha, A. (2017) proposed a WiFi based IoT garbage monitoring system was presented. Despite its ability to use WiFi transmissions to provide real time updates, there will be miscommunications when the person in charge of garbage is outside WiFi range.

### III. PROPOSED SYSTEM

In ‘Smart Garbage Bin Monitoring System’ system, the level of garbage in the dustbins is detected with the help of Sensor systems, and communicated to the authorized control room through GSM system. Microcontroller is used to interface the sensor system with GSM system. In this system, the Ultrasonic sensor is used for garbage level detection by using ultrasonic sound waves. Another Ultrasonic sensor is used to detect the movement of the user of the bin by opening and closing the bin automatically. GSM module is used for communication purpose, to send message to the higher officials when the dustbin is not cleaned. LCD is used to display the location of the dustbin that is full at the control room. Arduino board is used to interface the sensor, LCD and GSM module. The ultrasonic sensor is acting as level detector. The output of level detector is connected to the microcontroller. Depending on the microcontroller program, in first level the dustbin filled information is displayed on LCD and in second level if the dustbin is filled and not at cleaned then message send to the higher officials. The AT commands are used to facilitate the messaging service through the GSM Module. This program is embedded onto the microcontroller with the help of Arduino software (IDE). These messages consist of information of garbage levels of respective dustbins. Depending on the information sent to control room, the authority informs the concern person of the respective area about garbage level. Then the concerned person makes sure that the garbage of that particular area is collected by sending the cleaning vehicles.

#### A. Hardware requirements

The hardware requirement for the system is as follows:

**ULTRASONIC SENSORS:** (Detecting the level of Garbage). The Ultrasonic Sensor sends out a high-frequency

sound pulse and then times how long it takes for the echo of the sound to reflect back. The sensor has 2 openings on its front. One opening transmits ultrasonic waves, the other receives them. The speed of sound is approximately 341 meters (1100 feet) per second in air. The ultrasonic sensor uses this information along with the time difference between sending and receiving the sound pulse to determine the distance to an object. It uses the following mathematical equation:

$$\text{Distance} = (\text{Time} \times \text{Speed of Sound})/2 \quad (1)$$

Time: the time between when an ultrasonic wave is transmitted and when it is received.



Figure 1. Ultrasonic sensor

To measure the distance to an object, the time from transmission of a pulse to reception is measured and converted into arrange by knowing the speed of sound. This signal together with noise is then passed through various forms of signal processing, which for simple sensors may be just energy measurement. It is then presented to some form of decision device that calls the output either the required signal or noise. This decision device may be an operator with headphones or a display, or in some systems this function may be carried out by software. Further processes may be carried out to classify the target and localize it, as well as measuring its velocity. Some ultrasonic sensors have multiple beams to provide all round cover while others only cover an arrow arc, although the beam may be rotated, relatively slowly, by mechanical scanning.

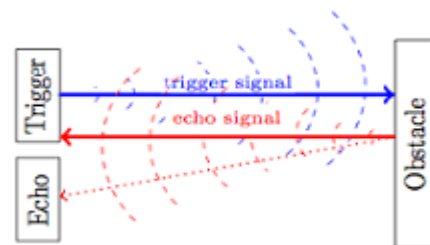

Figure 2. Ultrasonic sensor transmitting and receiving waves

**GSM Modem:** GSM Modem can accept any GSM network operator SIM card and act just like a mobile phone with its own unique phone number. Advantage of using this modem

will be that you can use its RS232 port to communicate and develop embedded applications. Applications like SMS Control, data transfer, remote control and logging can be developed easily using GSM as shown in Fig 3 as:



Figure 3. SIM900A GSM modem

The modem can either be connected to Arduino microcontroller through RS232. It can be used to send and receive SMS or make/receive voice calls. It can also be used in GPRS mode to connect to internet and do many applications for data logging and control. This GSM modem is a highly flexible plug and play quad band SIM900A GSM modem for direct and easy integration to RS232 applications. Supports features like Voice, SMS, Data/Fax, GPRS and integrated TCP/IP stack.

**LIQUID CRYSTAL DISPLAY:**

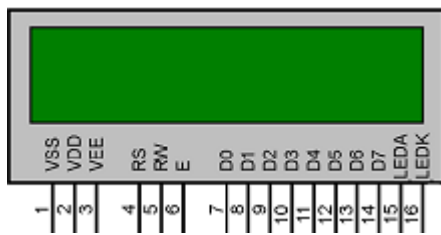

Figure 4. Liquid Crystal Display

The Fig 4 is used to display the dustbin location. A liquid crystal display (LCD) is a display module with liquid crystals and backlight by LEDs. A 16x2 LCD display consists of two rows of display with each row consisting of 16 characters. LCD Module has 16 pins and operates with 5V. Power pins i.e. pins 1, 2, 3, 15 and 16 are used to supply for the module as well as the backlight LEDs. The voltage to the Contrast Adjust Pin (Pin 3 or VEE) is usually given from a Potentiometer and will control the contrast of the actual display when the POT is adjusted. There are 8 data pins for transmitting 8bits of data i.e., 1 byte of data at a time. The LCD can be used in either 8bit mode or 4bit mode. The remaining three pins i.e. RS (Pin 4), RW (Pin 5) and E (Pin 6) are called the Control Pins and are very important pins. The RS pin, which is short for

Register Select pin, is used to select either Instruction Register when it is LOW or Data Register when it is HIGH. The RW pin or the Read/Write Pin is used for selecting Read Mode or Write Mode. When RW is HIGH, read mode is selected and data is read from the register. When RW is LOW, write mode is selected and data can be written in to the register. Since we are using the write mode only, we can connect the RW pin to ground (Through a pull down resistor). The Enable (E) pin, as the name indicates, is used to enable the execution of the data or instructions. The data or instruction are executed by the LCD module only when a HIGH to LOW pulse is given to the Enable pin i.e. only on the falling edge of a pulse.

**Arduino UNO:** The Arduino Uno is a microcontroller board based on the ATmega328 (datasheet). It has 14 digital input/output pins (of which 6 can be used as PWM outputs), 6 analogue inputs, a 16 MHz ceramic resonator, a USB connection, a power jack, an ICSP header, and a reset button. It contains everything needed to support the microcontroller; simply connect it to a computer with a USB cable or power it with an AC-to-DC adapter or battery to get started. "Uno" means one in Italian and is named to mark the upcoming release of Arduino 1.0. The Uno and version 1.0 will be the reference versions of Arduino, moving forward. The Uno is the latest in a series of USB Arduino boards, and the reference model for the Arduino platform.

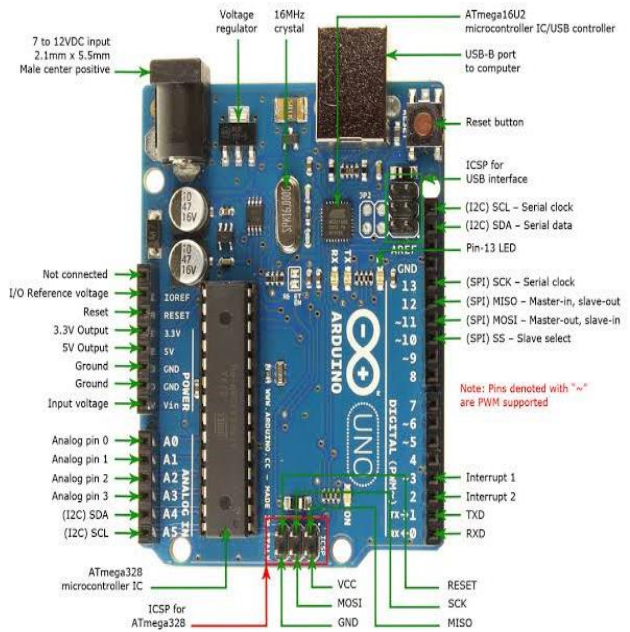

Figure 5- Arduino UNO

**B. Software Requirements**

The ATmega328p microcontroller needs to be programmed first before it can be used in the electronic hardware. A C/C++ programming language is chosen to program the microcontroller. Correct and functional codes ensure the microcontroller works properly. The functionality of the code

is verified using Arduino IDE, Proteus Virtual System Modelling (VSM) version 8.0 was used for the simulation and Arduino sketch 1.8.7 software was used for burning of the code into the microcontroller. After compiler operation, the hex code is generated and stored in the computer. The hex code of the program is burnt into the ATmega328p by using Arduino sketch 1.8.7 software. The software design started with the flow chart as shown in Figure 6. Figure 6 explains the flow of program for the smart based garbage bin monitoring system. The preparation symbol which is the "START" begins the programming process. The system is then initialized, connecting the various units of the circuit. After this, the status of the ultrasonic sensor and GSM module is checked to know the state of the device. Then a decision is made; if the ultrasonic sensor is active i.e if the garbage in the bin reaches a predefined level, the correspondent LED will come up and predefined message is sent to designated phone number through GSM module or if the user reaches a predefined distance, the relay is triggered and the lid of the bin opens. If on the other hand the sensor is not active, it returns to data symbol to check the sensor status again.

**IV. DESIGN AND IMPLEMENTATION**

The project is divided into two modules, one is detection of garbage level and then the second module is sending the information to the corresponding officials through GSM.

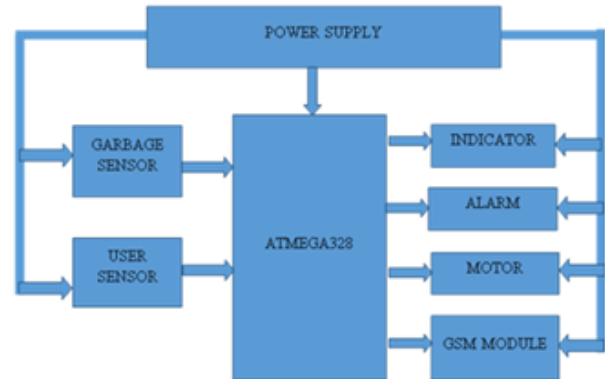

Figure 7. System Flow Chart

Fig 7 shows how the system operates. The operation starts as soon as the system is powered. The microcontroller will search for the available module and Network. The ultrasonic senses the level of the bin and sends the data to the microcontroller and the microcontroller processes the data received from the ultrasonic sensor. Depending on the data processed the status of the garbage in the garbage bin will be informed to the society through the LED. When the garbage status is high or full, the information will be passed to the control room through GSM. The user sensor senses the presence of the user and sends the data to the microcontroller and then microcontroller processes the data received from user sensor and then drives the motor to open or close the bin lid depending on the data the microcontroller received.

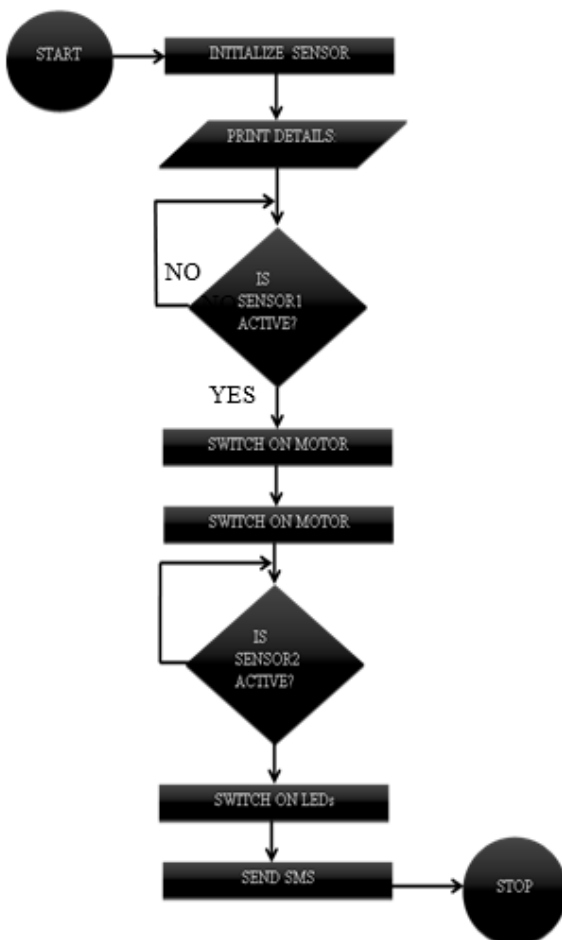

Figure 6. System Flow Chart

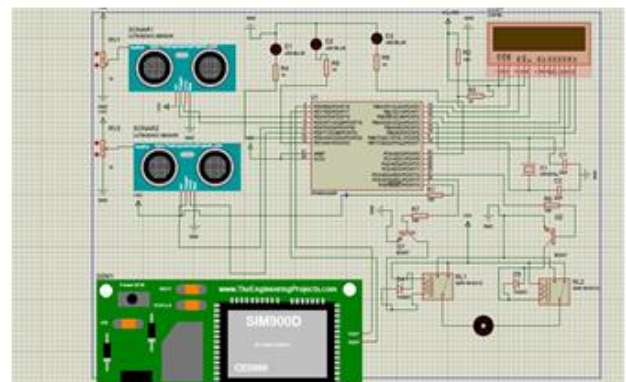

Figure 8. Circuit Diagram of Garbage Monitoring System



Figure 9. Implementation Garbage Monitoring System



Figure 10. Implementation Garbage Monitoring System

Figures 9 and 10 explain the full implementation of smart based garbage bin monitoring system with SMS feedback.

Garbage level detection is done by Ultrasonic sensor (HC-SR04). The Ultrasonic sensor is placed on the top of the dustbin lid facing the bottom while the other one is placed by the side of the bin. The sensors continuously emit the sonic waves, when the sonic waves hit the object and reflect back, the echo in the sensors senses the waves and calculate the distance of the object. Arduino Uno (Atmega328) is used for controlling the whole process of detecting garbage in different places and depending on the response displayed in LCD gives the garbage level in the bin and if the garbage is not taken out from the bin then the particular bin information is sent to higher official through GSM.

## V. CONCLUSION AND FUTURE WORK

Garbage monitoring system is a new idea of implementation which makes a normal dustbin smart using sensors for garbage level detection and sending message to the user updating the status of the bin. As soon as the dustbin is full it gives the information in LCD and sent the message to the corresponding officials.

In the future, an energy harvesting technique could be added in order to enhance the sustainability of the system. A gesture recognition system could be added in order to enhance the range and smartness of the system

## ACKNOWLEDGEMENT

The authors are really thankful to the Department of Computer and Communications Engineering, Abubakar Tafawa Balewa University (ATBU), Bauchi, Nigeria for the provision of facilities, materials and enough time that make this work into completion.

## VI. REFERENCE

- [1] Ali, M. L. Alam, M. and Rahaman, M. A. N. R.(2012). RFID based e-monitoring system for municipal solid waste management. 2012. In *proceedings of 7th International Conference on Electrical and Computer Engineering*, Dhaka, , pp. 474-477. doi: 10.1109/ICECE.2012.6471590
- [2] Yoada, R.M., Chirawurah, D. and Adongo, P.B. (2014) Domestic waste disposal practice and perceptions of private sector waste management in urban Accra. *BMC Public Health* **14**, 697 <https://doi.org/10.1186/1471-2458-14-697>.
- [3] Wang, L. K., Hung, Y. T., and Shamma, N. K. (2009). *Handbook of advanced industrial and hazardous wastes treatment*. CRC Press.
- [4] Twinkle, S. Mugesh Kumar, K. and Saisharan, P. (2015) .Smart Dustbin. *International Journal of Industrial Electronics and Electrical Engineering (IJIEEE)*, 3(5).
- [5] Gogoi, L. (2012) Solid Waste Disposal and its Health Implications in Guwahati City: A Study in Medical Geography, *Lambert Academic Publishing*, Germany.
- [6] Shinde, V., Bhutkar, G., and Pawar, V. (2017) Overview of Garbage Monitoring System. *Humanizing Work and Work Environment (HWWE)*, Conference proceedings, At Aligarh Muslim University (AMU), Aligarh, UP, India
- [7] Zarith, S.M. 2010. *Design and Construction an Automatic Waste Bin*. Under graduate preoject report. Department of Electrical Engineering, University of Technology Malaysia
- [8] Khalil, M.T. (2015) Design and Construction of an automatic dustbin with an alarm system *Undergraduate*



*project report*. Department of Electrical/Electronic Engineering University of Ilorin, Kwara state.

- [9] Ajiboye, T.S. (2015) Design and Construction of an automatic dustbin for office use only *H.N.D. project report*. Department of Electrical and Electronics Engineering Kwara State polytechnic, Kwara state
- [10] Chaware, S. M., Dighe, S., Joshi, A., Bajare, N., & Korke, R. (2017). Smart garbage monitoring system using Internet of Things (IoT). *Ijireeice*, 5(1), 74-77.
- [11] Rohan, D., Roopa K. G., Soujanya S., Varshitha S, and Dr. Shilpa R, (2019), GPS Based Garbage Tracking System, INTERNATIONAL JOURNAL OF ENGINEERING RESEARCH & TECHNOLOGY (IJERT) NCRACES – 2019 (Volume 7, Issue 10).
- [12] Anitha, A. (2017). Garbage monitoring system using IoT. In *14th ICSET-2017, IOP Conf. Series: Materials Science and Engineering* (Vol. 263, p. 042027).

# IJEAST

INTERNATIONAL JOURNAL  
OF ENGINEERING APPLIED SCIENCE  
AND TECHNOLOGY

## ABOUT IJEAST

International Journal of Engineering Applied Science and Technology (IJEAST) is a peer-reviewed, open access journal that publishes high-quality research papers in the field of Engineering, Applied Science and Technology.

IJEAST aims to provide a platform for researchers, academicians, and professionals to share their innovative ideas, research findings, and practical experiences with the global scientific community.

## FOCUS AREAS

- Engineering
- Applied Science
- Technology
- Innovation & Development
- Interdisciplinary Studies



### PEER REVIEWED

All submissions are rigorously peer reviewed to ensure quality.



### OPEN ACCESS

Free and unrestricted access to research for all.



### GLOBAL REACH

Connecting researchers and professionals worldwide.



### TIMELY PUBLICATION

We ensure a swift and efficient publication process.



For more information, visit our website

[www.ijeast.com](http://www.ijeast.com)



INTERNATIONAL JOURNAL  
OF ENGINEERING APPLIED SCIENCE  
AND TECHNOLOGY

✉ [editor@ijeast.com](mailto:editor@ijeast.com)

🌐 [www.ijeast.com](http://www.ijeast.com)

📍 India



2455-2143