



# IJEAST

INTERNATIONAL JOURNAL  
OF ENGINEERING APPLIED SCIENCE  
AND TECHNOLOGY



**VOLUME : 8    ISSUE : 01    Print / Issue Publication Date: 12-Jul-2023**



**ISSN : 2455-2143**



**DOI : 10.33564/IJEAST.2023.v08i01.033**

Indexed In



[WWW.IJEAST.COM](http://WWW.IJEAST.COM)

[editor@ijeast.com](mailto:editor@ijeast.com)



# MODELING AND FABRICATION OF 5 – SPEED GEARBOX USING 3D PRINTING WITH OPTIMUM WEIGHT

Prof.A.R.Devshette, Purvesh Mehta, Saurabh Zambare, Ghanshyam Patil, Vinit Chaudhari  
Department of Mechanical Engineering  
JSPM's RSCOE, Pune, Maharashtra, India

**Abstract** - The main aim of the project is to focus on the modeling and 3D printing of synchromesh gear box and the weight reduction of it using different 3D printing techniques like SLS, SLA, DLP, FDM. Differential permit each of the driving wheels to rotate at different speeds, while for most vehicles supplying equal torque to each of them. A vehicle's wheels rotate at divergent speeds, mainly when turning corners. The differential is designed to operate a pair of wheels with same torque while permit them to rotate at different speeds. Additive manufacturing education is becoming to widespread adoption. Additive manufacturing is also the manufacturing technology. It is used by multiple industry subsectors, including motor vehicles, aerospace, machinery, electronics, and medical products. It can facilitate the customized production of strong light-weight 3D modeling. This paper describes 3D modeling of five speed transmission is designed and constructed by using AutoCAD software, 3D Mesh software, MakerBot 3D printer and digitizer. This 3D modeling of five speed transmission is good quality through lighter part, can demonstrate easily. The teacher can take 3D modeling of transmission and teach the operations of transmission in the classroom. It can produce the gears, fork, cover and synchronizer sleeves with different color. Many beautiful colors are interested to the students. So, it can use as teaching aids for the engineering students. In this transmission, five forward speed gears are helical type whereas reverse gears are spur type. Design consideration of spur gear and helical gears and shafts are included in this paper. In gear design, the number of teeth, face width, gear tooth features and pitch diameter are calculated. The shafts are designed according to the point of view of the strength.

**Keywords** - Additive Manufacturing synchromesh gear box, powertrain design; 3D printing; 3D modeling; gears;

## I. INTRODUCTION

A gear is a component that is used to transfer torque from a rotating input. It uses teeth to mesh together with other gears in order to transmit movement; usually gears that mesh together have identical type of teeth. Two gears together will

form a transmission that is capable of changing speed, torque, and direction of the power source. A desired output of speed and torque can be obtained by controlling different geometry sizes between two gears. The transmission has the capability to enable the engine turning effect and its rotational speed output to be adjusted by choosing a range of under and overdrive gear ratios. So the vehicle responds to the driver's requirements within the limits of the various road conditions. There are two types of transmission, manual and automatic. Both do the same job. Manual transmission consists of cast iron or aluminium housing, shafts, bearings, gears, synchronizing devices and shifting mechanisms. Automatic transmission includes a torque converter, compound planetary gear set, two or more disc clutches and one or more bands.

Additive manufacturing is a new and innovative method used to manufacture solid objects. It allows the user to make the complicated 3D model using a method of manufacturing for a part is made by adding layer after layer of a heated material that cools and solidifies almost instantly. These 3D shapes are initially created on a computer using solid modelling software, which can be downloaded into the printer. Depending on shape, material, series volume and other criteria, series production is economically possible using metal additive manufacturing. Additive manufacturing system is a process by which digital 3D design data is used to build up a component in layers by depositing material. A range of different metals, plastic and composite materials may be used in additive manufacturing system. In this paper, 3D modelling transmission for Toyota 22RE engine produced by using additive manufacturing method is shown in five speed manual transmission includes five forward gears and one reverse gear, applying advanced monolithic structure of the intermediate shaft and the shift lock ring-type synchronizer. The transmission possesses a compact structure, a small size, high transmission efficiency, and a larger ratio range, with good economy and dynamic performance. Each process is limited to one type of material and only few are able to process more than one material e.g. thermoplastics of different colour.

All of the steps are included for a better understanding of the working principles. Most often, the torque and angular speed of an combustion engine do not match the actual movement of an automobile. The main subassembly that ensures the



speed and traction force conversion, without modifying power parameters develop day an combustion engine, is known as a gearbox. The main functions of a gearbox are: to change gear ratios between the engine crankshaft and the vehicle drive wheels, to be shifted into reverse so the vehicle can move backwards, to be shifted into neutral for starting the engine

In automobiles and other wheeled vehicles, the differential permit each of the driving wheels to rotate at different speeds, while for most vehicles supplying equal torque to each of them. A vehicle's wheels rotate at divergent speeds, mainly when turning corners. The differential is designed to operate a pair of wheels with same torque while permit them to rotate at different speeds. In vehicles without a differential, such as karts, both driving wheels are forced to rotate at the equal speed, generally a common axle driven by a simple chain drive mechanism. When cornering, the inner wheel needs to travel a shorter distance than the outer wheel, so with no differential, the result is the inner wheel spinning and/or the outer wheel dragging, and this results in difficult and unpredictable handling, damage to tires and roads, and strain on the entire drive train. The Differential transmits mechanical energy from a prime mover to an output device. It also varies the speed, direction of mechanical energy. Differential gearbox is used when high speed, large power transmission where noise reduction is important.

## II. MATERIAL SELECTION

**Material used for 3D printing of 5speed synchromesh gear box :-**

### a) **Aura 25- Stereolithography (SLA)**

Accura 25 is a durable and flexible SLA 3D printing material. With a Shore D Hardness of 80, Accura 25 can be used as an alternative to machined Polypropylene and ABS. It's ideal for snap-fit part designs, as a master pattern for urethane casting, and conceptual modelling. Accura 25 can be used for functional prototyping or end-use parts, but parts with this purpose are typically restricted to short production runs. In terms of aesthetics, the material has excellent resolution, dimensional accuracy, and can be primed and painted after printing. Used for printing the gears with 100microns accuracy

### b) **PA2200 – Selective lazer sintering (SLS)**

PA 12 (as powder also called PA 2200) is one of the single most versatile materials in professional 3D printing. Due to its mechanic strength, flexibility and heat resistance, it is a perfect choice for functional prototypes or end-use parts. Printing PA12 requires no support structures and therefore enables printing even the most complex designs. Used for casing and non-working parts like casings gearbox stand etc.,.

### c) **Fig 4 Standalone – DLP- Pro Black**

Production-grade additive manufacturing material with game-changing thermoplastic-like mechanical properties and long-term environmental stability Versatile Rigid Heat-Resistant

Material Combines Speed, Strength, Excellent Mechanical Properties for Tool-Less, Direct Production of Plastic Parts Figure 4 PRO-BLK 10 delivers on the promise of additive manufacturing with true direct digital production of plastic parts. Go from CAD to manufacturing line in one day with tool-less, same day part production. With a fast print speed and simplified post-processing that includes a single curing cycle and single solvent cleaning, this material delivers exceptional throughput. It is a high precision resin producing parts with a smooth surface finish and sidewall quality, and has excellent mechanical properties and long-term environmental stability that brings a new level of assurance to 3D production. Used for micro and nano parts printing of gear box like shifter balls and shifter linkages

### d) **PLA - Fuse deposition modelig FDM**

PLA plastic or polylactic acid is a vegetable-based plastic material, which commonly uses cornstarch or sugarcane as a raw material. The monomer is usually made from fermented plant starch. This material is a thermoplastic aliphatic polyester and it is the primary natural raw material used in 3D printing. PLA is a fully biodegradable thermoplastic polymer consisting of renewable raw materials. Among all 3D printing materials, PLA is part of the most popular materials used for additive manufacturing for filament fabrication. Used for printings the covers and cluth plate.

## III. PROBLEM STATEMENT AND OBJECTIVE

### **PROBLEM STATEMENT**

Modeling and Fabrication of 5 – speed Gearbox using 3D Printing with optimum weight and optimum cost.

#### **Advantages:-**

1. **Lower labor costs.** You don't need extensive training to operate a 3D printer. Accordingly, using a 3D printer for manufacturing can reduce the amount of hours you need to spend and lower your labor costs in turn.
2. **Higher customization potential.** 3D printing is highly flexible, meaning there's higher potential for customization. When designing gears to be produced through 3D printing, there's no limit to what you can create.

#### **Disadvantages:-**

1. **Material availability.** While there are some types of plastic gears, most gears rely on metal or some other highly durable material. 3D printing hasn't yet caught up to this need.
2. **Technology cost and advancement.** Currently, 3D printers aren't far along in their development; some equipment is cost-prohibitive, and some equipment simply isn't advanced enough for precision manufacturing.

3. **Printing speeds.** Though multiple 3D printers could conceivably speed up overall production, individual printing times are slow compared to traditional manufacturing processes.

**OBJECTIVES**

- ❑ The Designing of automobile power transmission system using CATIA V5 software.
- ❑ 3D printing of gears using SLA, SLS, FMD, DLP printers. We are using these methods to print our components.
- ❑ To Reducing weight of the gearbox by using different methods, different material also different internal structures.
- ❑ To Reducing the cost by reducing the usage of the material by hollowing the components.
- ❑ To reducing the weight we are increasing the efficiency of the gearbox.
- ❑ By using different internal structure we are providing high strength to our gearbox
- ❑ To get High dimensional accuracy.

**IV. WORKING PRINCIPLE**

**Power Transmission System in Automobile**

The power transmission system in automobile consists of two parts; transmission gearbox and differential. The power is produced in the engine by the reciprocating motion of piston. The power thus produced is transferred to the transmission gear box via rotary motion of the crank shaft. To transfer or disengage the power between engine and the transmission gearbox, a clutch system is located between them. Various range of motion is obtained at the gearbox output shaft through different gearing arrangements. This motion of the output shaft is then transferred to the differential. Finally, the power from differential is transmitted to both the road wheels according to the speed requirement.

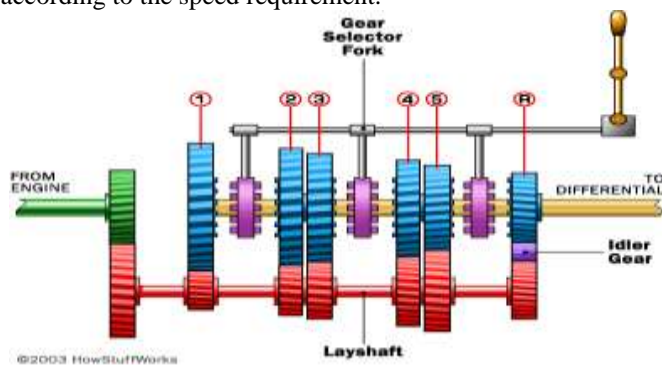

The basic function of the transmission is to control the speed and torque available to the road wheels for different driving conditions. For example, to climb a hill, a vehicle needs more torque. This torque can be obtained by reducing the speed at the transmission. This is clearly seen in equation . If the angular speed of the gear is decreased, it generates more

torque for the same power input. Similarly, if the torque demand is low, the angular speed of the gear must increase. The working of manual transmission is based on the principle of gearing and the gear ratio. As shown in figure, the input shaft (green shaft) from the engine and the output shaft (yellow shaft) from the differential are connected through a layshaft (red shaft). The gears are always in mesh with each other, but the output gears are loosely connected to the output shaft. To obtain a particular speed at a time, only one gear should be attached to the output shaft at that particular instance. This is achieved by using selectors as shown in the figure above. Sliding the selector and meshing it with any particular gear engages that gear.

**V. DESIGN CALCULATIONS**

“Gears are defined as toothed wheels or multilobed cams, which transmit power and motion from one shaft to another by the means of successive engagement of teeth.” (V B Bhandari , 2006).

During transfer of motion between two tangentially connected smooth shafts, slipping usually takes place. This reduces the velocity ratio and power transmission between the shafts. Addition of meshing teeth helps to overcome slip between belt and shaft thus maintaining positive drive in the system. “The motion and power transmitted between gears can be considered kinematically equivalent to that transmitted between frictional wheels.” (R.S. Khurmi, 2005).

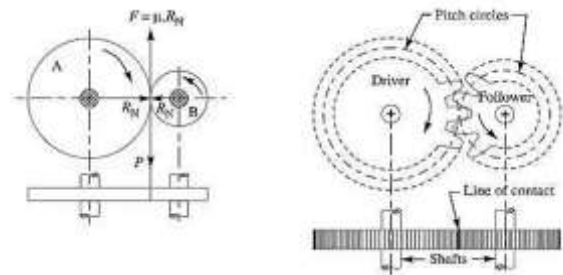
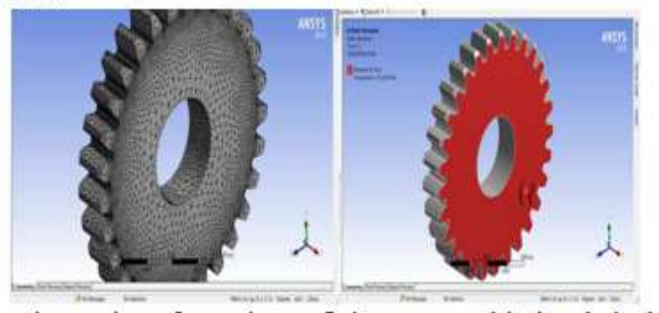

Fig.1.1 Friction Wheels and Gear or Tooth Wheels

**Spur Gear**

**Terminology of Spur Gear**

Terms used in gears includes many peculiar definitions. The picture below indicates some of the parametric terms that are used to define the properties associated with spur gears.



Some of the terminology associated with spur gears is mentioned below:

1. Pitch Circle: It is an imaginary circle that rolls to represent the motion of actual gear. It is tangent with the pitch circle of a mating gear.
2. Pitch Circle Diameter ( $D$ ): “The pitch circle diameter or pitch diameter is the diameter of a pitch circle. The size of a gear is usually specified by pitch diameter.”
3. Addendum: “It is the radial distance of a tooth from the pitch circle to the top of the tooth.”
4. Dedendum: “It is the radial distance of a tooth from the pitch circle to the bottom of the tooth.”
5. Circular Pitch ( $P_c$ ): “The circular pitch is the arc length along the pitch circle circumference measured from a point on one tooth to the same point on the next. It defines the tooth size.”

$$P_c = \frac{\pi D}{T}$$

Where,  $D$ =pitch diameter,  $T$ =number of teeth

6. Diametric Pitch ( $P_d$ ): “It is the ratio of number of teeth to the pitch circle diameter in millimeters.”

$$P_d = \frac{T}{D} = \frac{\pi}{P_c}$$

7. Module ( $m$ ): “A module is inverse of diametral pitch or the ratio of pitch circle diameter in millimeters to the number of teeth.” (R.S. Khurmi, 2005). Basically, a module indicates how big or small the gear is. For two gears to mesh, they must have same module.

$$m = \frac{D}{T}$$

8. Velocity ratio or speed ratio ( $m_V$ ): “It is the ratio of angular velocity of the driving gear to the angular velocity of the driven gear.”

$$m_V = \frac{\omega_{out}}{\omega_{in}} = \pm \frac{r_{in}}{r_{out}}$$

9. Transmission ratio ( $m_V'$ ): “It is the ratio of angular velocity of the first driving gear to the angular velocity of last driven gear in the gear train.”

$$m_V' = \frac{\omega_{first}}{\omega_{last}}$$

10. Clearance: “It is the amount by which the dedendum of a given gear exceeds the addendum of its mating tooth.” (V B Bhandari, 2006).

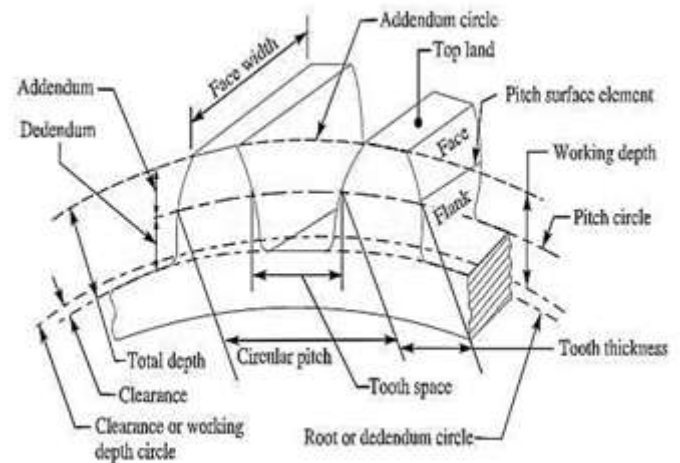

Fig.1.2 Terminology of spur gear

### ANALYSIS AND CAD MODEL

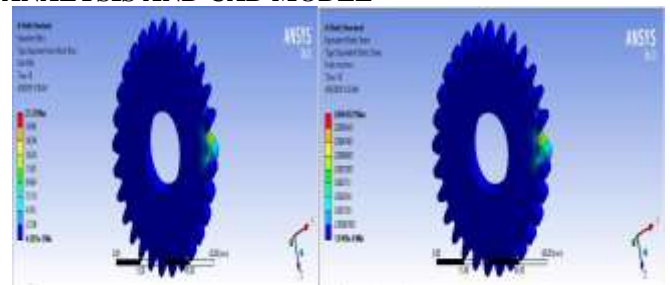

Fig.1.3 Gear analysis in Ansys under tangential load of 280 N

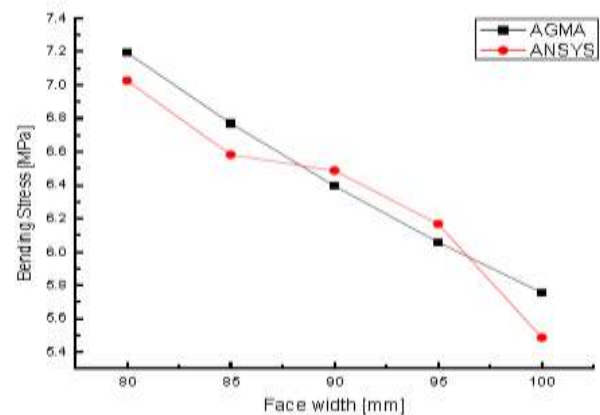

Fig 1.4 Graph of Bending Stress [MPa] against Face width [mm]

Assembly and Cad Model of Gear Box

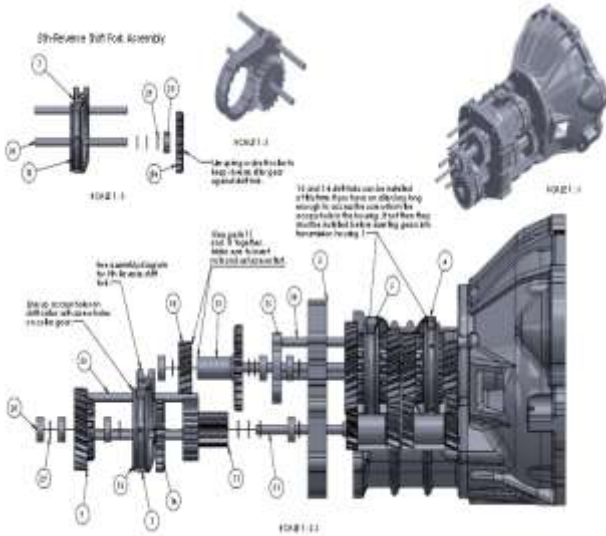

Fig 5<sup>th</sup> reverse shift fork assembly

Note: Make sure to insert nuts and set screws into pieces before assembly.

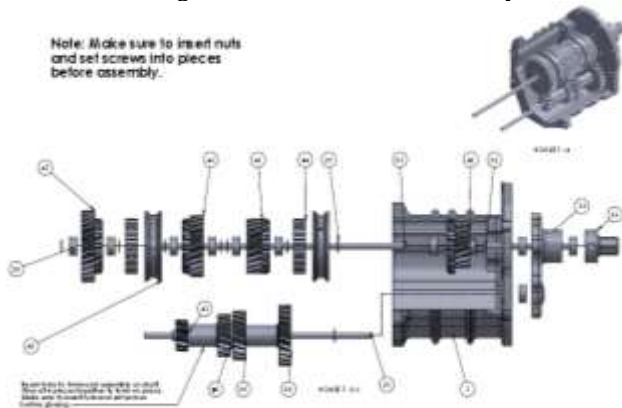

Fig 1. set screw and nuts assembly

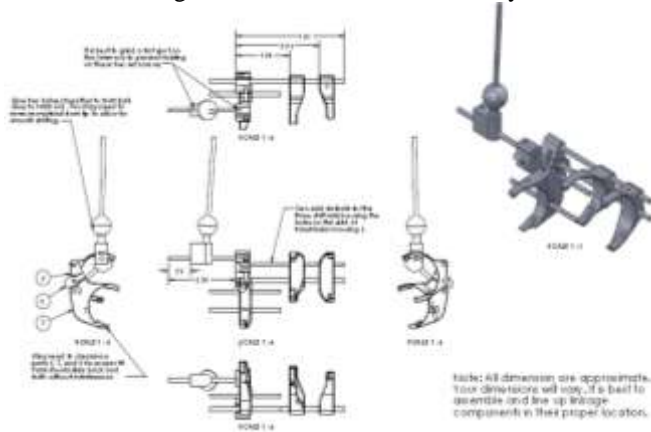

Fig 1. shifter link assembly



Fig. Assembly of 5 speed Gearbox

VI. RESULT AND CONCLUSION

From all the above research and analysis we have come to the conclusion that by using the 50-60% of the internal structures like using honey comb, lines, hexagons, rectangles squares 3D infill's etc. we can reduce the weight without affecting the strength of the components or parts and the strength will be same as the solid parts have no effect will be observed. In this transmission, there are all together five forward speed and one reverse. Among the five forward speeds, the fourth drive is the direct drive and the final drive is the overdrive. The design calculation is based on maximum tangential load at 1st speed range.

3D printing is a quick, simple and relatively cheap method for production of models for automobile teaching aids. As it was presents a wide range of materials and technologies with various features and parameters are available. This enables a potential researcher to choose the right technology fitting exactly the needs and fulfilling the requirements of prepared experiment. Thin walled and tough models have been successfully manufactured. In this design, structural rigidity combined with lightness must always be the first consideration for the durability of the wearing parts and smoothness of running.

Table no. 1 material costing

Results and Conclusion	
Weight reduction	40.42%
Cost reduction	33.55%
Infill percentage	50-60%

Table no. 2 results and conclusion

Materials costing per gram	
Material	Cost per gram
SLA Acura 25	140/gm
Fig-4 pro black	120/gm
SLS powder	70/gm
FDM ABS,PLA	30/gm

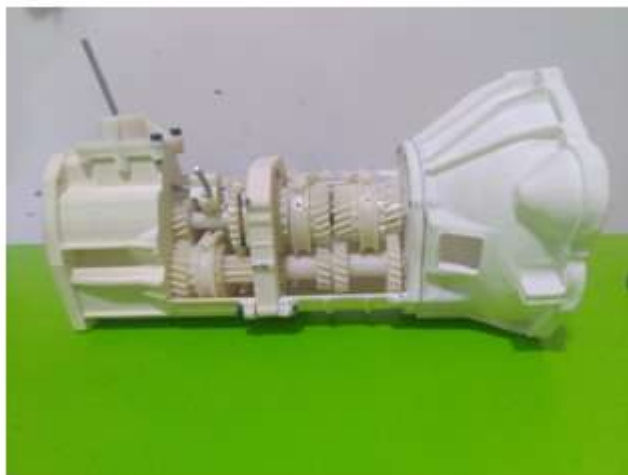

Fig. 5 speed gearbox

#### VII. REFERENCE

- [1]. Shashank pandey, Nikhilesh N. sing&Dr. rabhatkumar sinha,2017,"Modelling and design of differential gear box through FEM, SOLIDWORKS WORKBENCH", International Journal of Engineering Sciences and Research Technology.
- [2]. T. Loknadh, DR. P. S. S. Vasu , Design a crown wheel gear of differential gear box used in heavy vehicles for structural loads, International Journal of Science, Engineering and Technology Research (IJSETR), Volume 4, Issue 7, July 2015
- [3]. Roberson, D. A., Espalin, D., & Wicker, R. B., "3D printer selection: A decision making evaluation and ranking model", Virtual and Physical Prototyping, 2013, 8:3, 201-212.
- [4]. Lee, I. and Kim, Y., "The Recent Patent Analysis and Industrial Trend of 3DPrinting", Indian Journal of Science and Technology, Vol 8(S8), 70-73, April 2015
- [5]. Thompson S. M., Bianc, L., Shamsaei, N., &Yadollahia, A., " An overview of Direct Laser Deposition for additive manufacturing; Part I: Transport phenomena, modeling and diagnostics", Additive Manufacturing 8 (2015) 36–62,<http://dx.doi.org/10.1016/j.addma.2015.07.001>
- [6]. Shamsaei, N., Yadollahia, A., Bianc, L., & Thompson S.M.," An overview of Direct Laser Deposition for additive manufacturing; Part II: Mechanical behavior, process parameter optimization and control", Additive Manufacturing 8 (2015) 12–35,<http://dx.doi.org/10.1016/j.addma.2015.07.002>
- [7]. Linhong Xu Leiming Li Yin Liu ,Stress Analysis and Optimization of Gear teeth, International Conference on Measuring Technology and Mechatronics Automation2009. pp -895-898.
- [8]. B.Venkatesh, V.Kamala ,and A.M.K.prasad, Design, modeling and Manufacturing of helical gear,I international Journal Of Applied Engineering Research, ISSN 0976-4259. Volume 1, No1, 2010. pp 103-114.
- [9]. Arvind Yadav, Different types Failure in gears-A Review,International.Journal.of.Science Engineering and Technology Research (IJSETR) Volume 1, Issue 5, November 2012 , ISSN: 2278 – 7798,pp .86-92
- [10]. A.Y.V. Gopi Krishna, R.V. Kiran (2019) “Design And Analysis Of A Two Stage Reduction Gearbox” International Research Journal of Engineering and Technology (IRJET) Volume: 06 Issue: 12.
- [11]. Ujjayan Majumdar, Sujit Maity, Gora Chand Chell, (2018) “Design and Analysis of Six Speed Gear Box”, International Journal of Research in Engineering, Science and Management Volume-1, Issue-9,
- [12]. Heel Patel, Dhruv Wadhwa, Harsh Patel, Parth Trivedi, Jay Mandalia,(2018) “ Design & Manufacturing of Reduction ”,International Journal of Research in Science, Engineering and Technology.
- [13]. Francesca Cura,(2017) “Method for calculating a global dynamic factor KAV in gears subjected to variable velocity and loading conditions”, 7th International Conference on Fatigue Design, Fatigue Design, 29-30.
- [14]. Neeraj Patel, Tarun Gupta, Aniket Wankhade, Vilas Warudkar (2017) “Design and Optimization of 2-Stage Reduction Gearbox” International Journal of Engineering Development and research, Volume 5, Issue 2.
- [15]. Muhammad Irfan (2017) “Modeling and optimization of gear shifting Mechanism” Application to heavy vehicles transmission systems -Thesis for Licentiate of Engineering no 2017:01 ISSN 1652-8565.



- [16]. Rahi Jain and Pratik Goyal (2016) “Design and analysis of gear-box using spur gear and eliminating the differential unit” International Journal of Mechanical Engineering and Technology (IJMET) Volume 7, Issue 6.
- [17]. Bhatia, A., 2019. Basic Fundamentals of Gear Drives. [Online] Available at: <https://www.cedengineering.com/courses/basic-fundamentals-of-gear-drives> [Accessed 5 11 2019].
- [18]. Marshall Brain, C. T., 2019. A Real Transmission. [Online] Available at: <https://auto.howstuffworks.com/transmission4.htm> [Accessed 5 11 2019].
- [19]. R.S. Khurmi, J. G., 2005. A TEXT BOOK of MACHINE DESIGN. RAM NAGAR, NEW DELHI-110 055: EURASIA PUBLISHING HOUSE (PVT.) LTD.
- [20]. Spectrum Group Sp., 2019. Filament PLA Tough 2.85mm DEEP BLACK 1kg. [Online] Available at: <https://en.spectrumfilaments.com/product-eng-1164-Filament-PLA-Tough-2-85mm-DEEPBLACK-1kg.html> [Accessed 2020].
- [21]. Vaibhav S.Jadhav, Santosh R. Wankhade, 2017. Design&Manufacturing of Spur Gear Using Fused Deposition Modeling. International Research Journal of Engineering and Technology (IRJET), December, 04(12), pp. 1217-1222.

# IJEAST

INTERNATIONAL JOURNAL  
OF ENGINEERING APPLIED SCIENCE  
AND TECHNOLOGY

## ABOUT IJEAST

International Journal of Engineering Applied Science and Technology (IJEAST) is a peer-reviewed, open access journal that publishes high-quality research papers in the field of Engineering, Applied Science and Technology.

IJEAST aims to provide a platform for researchers, academicians, and professionals to share their innovative ideas, research findings, and practical experiences with the global scientific community.

## FOCUS AREAS

- Engineering
- Applied Science
- Technology
- Innovation & Development
- Interdisciplinary Studies



### PEER REVIEWED

All submissions are rigorously peer reviewed to ensure quality.



### OPEN ACCESS

Free and unrestricted access to research for all.



### GLOBAL REACH

Connecting researchers and professionals worldwide.



### TIMELY PUBLICATION

We ensure a swift and efficient publication process.



For more information, visit our website  
[www.ijeast.com](http://www.ijeast.com)



INTERNATIONAL JOURNAL  
OF ENGINEERING APPLIED SCIENCE  
AND TECHNOLOGY

✉ [editor@ijeast.com](mailto:editor@ijeast.com)

🌐 [www.ijeast.com](http://www.ijeast.com)

📍 India



2455-2143