



IJEAST

INTERNATIONAL JOURNAL
OF ENGINEERING APPLIED SCIENCE
AND TECHNOLOGY



VOLUME : 2 ISSUE : 5 Print / Issue Publication Date: 11-Aug-2017



ISSN : 2455-2143



Indexed In



WWW.IJEAST.COM

editor@ijeast.com

CLASSICAL AND ARTIFICIAL OPTIMIZATION TECHNIQUES TO ENHANCE POWER SYSTEM OPERATION

Ibrahim M. Diao, Niveen M. Badra
 Department of Engineering Physics and Mathematics,
 Faculty of Engineering, Ain Shams University, Cairo, Egypt

Mahmoud A. Attia
³Department of Electrical Power & Machines,
 Faculty of Engineering, Ain Shams University, Cairo, Egypt

Abstract— *There are several power system problems greatly affects its stability. Some of these problems is the outage of the transmission lines causing power system failure. In this paper, Insertion of FACTS devices proposed as a solution to this problem. Optimal location and sizing of FACTS devices play an important role in the recovery of the system stability. Whale optimization algorithm and mixed-integer nonlinear programming optimization techniques are proposed as a solution to this problem. The minimization of the total power system loss is the objective function. A comparison with other artificial optimization techniques has proven the superiority of the proposed techniques against other artificial techniques. The power system under study is the IEEE 30 bus system.*

Keywords— *Whale Optimization Algorithm, Mixed-Integer Nonlinear Programming, Flexible AC Transmission Systems, Loss Minimization*

I. INTRODUCTION

Flexible AC Transmission Systems devices have been widely used in power system in order to deal with several problems. Power system failure due to line outage or outage of a generator arise a great dis-functionality of the delivered power to the load as some of the transmission are heavily loaded than others exceeding limits. FACTS devices plays important role in the recovery of the system indices to its steady state and the recovery of the delivered power through transmission lines within acceptable limits.

Several objectives used to optimally locate and size FACTS devices. The objective function used in this paper is the minimization of the total power system losses.

Several types of FACTS devices were used in power system. The FACTS device considered in this paper is the Thyristor Controlled Series Compensator (TCSC). TCSCs

insertion helps greatly in the restoration of the system operating limits. TCSC is modeled as a capacitance or inductance connected (X_{TCSC}) in series with the line reactance (X). The reactance of the TCSC is calculated as a percentage of the line reactance (r_{TCSC}). In this paper r_{TCSC} is taken between 30 and 70 percent of the transmission line. Hence, the total reactance (X_{total}) of the line is the summation of the line reactance and the TCSC reactance. Figure 1 shows the modeling of the TCSC devices.

$$X_{total} = X + X_{TCSC}$$

$$X_{TCSC} = r_{TCSC} \times X$$

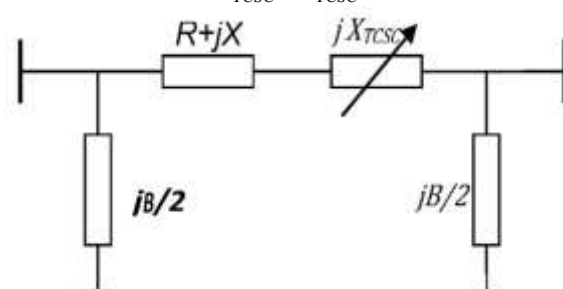

Fig. 1. TCSC Model

A thyristor-controlled reactor (TCR) connected in parallel with a capacitor is the TCSC device. FACTS device doesn't require any interfacing equipment, like high voltage transformers. TCSC device is connected in series with the transmission line to be compensated. Series compensation property of TCSC device makes it more economic competing other FACTS technologies.

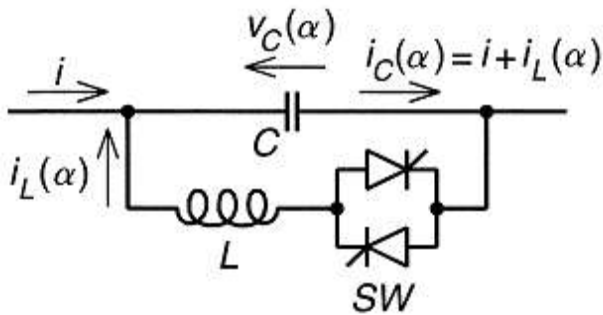

Fig. 2. TCSC Schematic Diagram

TCSC equation is given by:

$$X_{TCSC}(\alpha) = \frac{X_C X_L(\alpha)}{X_L(\alpha) - X_C}$$

$$X_L(\alpha) = X_L \frac{\pi}{\pi - 2\alpha - \sin\alpha}$$

$$X_C = \frac{1}{\omega C}$$

Where α is the firing angle.

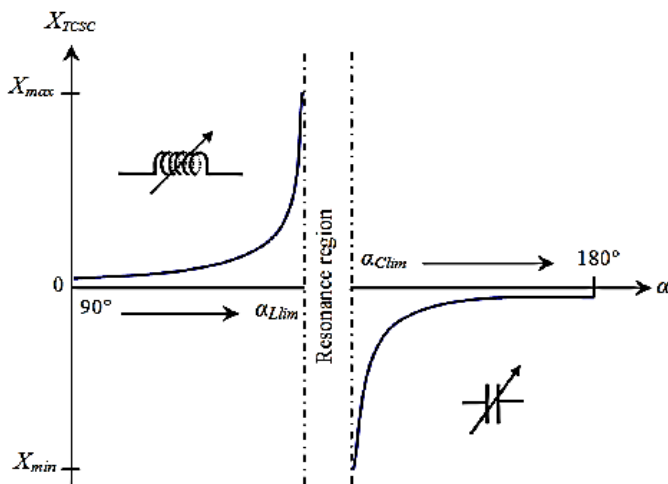

Fig. 3. TCSC reactance vs firing angle α

Several optimization techniques used to optimally allocate FACTS devices. Authors in [1] used linear programming, Authors in [2] used quadratic programming, Authors in [3,4] used nonlinear programming, Authors in [5] used interior point method, Authors in [6] used evolutionary programming, Authors in [7] used particle swarm optimization method, and authors in [8-10] used genetic algorithm.

In this Paper, two optimization techniques are used for

finding the optimal location and sizing of TCSC devices in order to minimize total system losses. The IEEE 30-bus system was examined by the proposed optimization techniques successfully.

II. PROBLEM FORMULATION

The goal of this paper is to find the optimal location and sizing of the TCSC devices in order to restore the system to its stable state. The optimization problem is formulated as follows:

A. Objective Function

Economically, the minimization of active power losses P_{loss} is taken into consideration. P_{loss} expression is:

$$P_{Loss} = \sum_{r=1}^{nbr} g_r [V_i^2 + V_j^2 - 2V_i V_j \cos(\delta_i - \delta_j)]$$

B. System Constraints

The load flow equations are represented by the equality constraints represent as follows:

$$P_{g_i} - P_{D_i} - V_i \sum_{j=1}^{nb} V_j [G_{ij} \cos(\delta_i - \delta_j) + B_{ij} \sin(\delta_i - \delta_j)] = 0$$

$$Q_{g_i} - Q_{D_i} - V_i \sum_{j=1}^{nb} V_j [G_{ij} \sin(\delta_i - \delta_j) - B_{ij} \cos(\delta_i - \delta_j)] = 0$$

where $i = 1, \dots, nb$

System operating limits are the inequality constraints.

The optimization parameters are the location and the sizing of the TCSC devices.

III. WHALE OPTIMIZATION ALGORITHM

Recently a new heuristic optimization technique proposed by Mirjalili et al. [11] inspired by humpback whales behavior. The methodology used by those whales for hunting their preys is the bubble-net feeding method [12] as shown in figure 4.



Fig. 4. Bubble-net feeding

The procedure of finding optimal solution passes by three stages and they are encircling prey, bubble-net attacking method, and searching for prey. The Pseudo-code of WOA algorithm is shown in figure 5.

IV. MIXED-INTEGER NONLINEAR PROGRAMMING

```

Initialize the whales population  $X_i$  ( $i = 1, 2, \dots, n$ )
Calculate the fitness of each search agent
 $X^*$  = the best search agent
while ( $t <$  maximum number of iterations)
    for each search agent
        Update  $a, A, C, l$ , and  $p$ 
        if1 ( $p < 0.5$ )
            if2 ( $|A| < 1$ )
                Update the position of the current search agent
            else if2 ( $|A| \geq 1$ )
                Select a random search agent ( $X_{rand}$ )
                Update the position of the current search agent
            end if2
        else if1 ( $p \geq 0.5$ )
            Update the position of the current search
        end if1
    end for
    Check if any search agent goes beyond the search space and amend it
    Calculate the fitness of each search agent
    Update  $X^*$  if there is a better solution
     $t = t + 1$ 
end while
return  $X^*$ 
    
```

Fig. 5. Pseudo-code of WOA algorithm

Mixed-integer nonlinear programming (MINLP) was proposed in 1960's [13-15] to solve mixed-integer linear programming. The MINLP problem is formulated as follows:

$$\begin{aligned}
 & \min f(\mathbf{x}, \mathbf{y}) \\
 & \text{subject to } \mathbf{h}(\mathbf{x}, \mathbf{y}) = \mathbf{0} \\
 & \text{(MINLP) } \mathbf{g}(\mathbf{x}, \mathbf{y}) \leq \mathbf{0} \\
 & \mathbf{x} \in R^n \\
 & \mathbf{y} \in Z^m
 \end{aligned}$$

Where \mathbf{x} is the vector n number of continuous variables and \mathbf{y} is the vector of the m number of integer variables.

L : List of unsolved subproblems.

(x^*, y^*) : Incumbent solution.

ub : Upper bound

lb : Lower bound

S : Subproblem

The branch and bound optimization algorithm is used to solve the MINLP problem. The branch and bound optimization algorithm is discussed in the flowchart shown in figure 6.

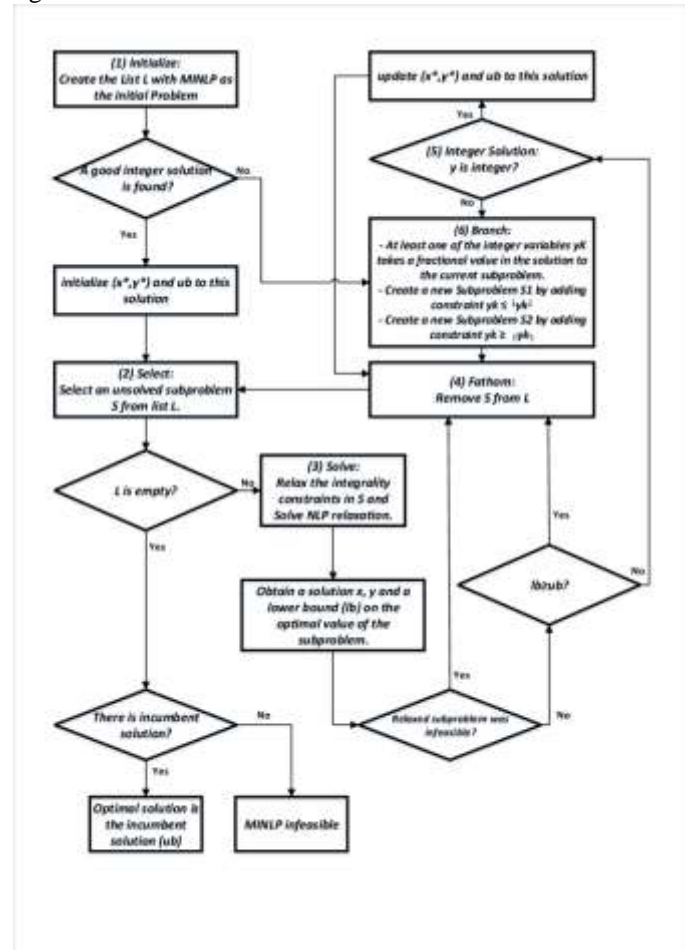

Fig. 6. Branch and Bound Algorithm

V. CASE STUDY

The optimization techniques were applied to the modified IEEE 30-bus system given in [16]. The obtained results are compared with [17]. Authors in [17] used Harmony Search Algorithm (HS) and Teaching-Learning Based optimization algorithm (TLBO) in order to find optimum location and sizing of TCSCs.



The system under test is shown in Figure 7 as a one-line diagram. Data of the system is given in [16]. System study was carried out at the outage of the line joining bus 1 and bus 2, and also increasing the load connected to bus 8 by 50%. The range of TCSCs carried out in this study is from -30% to -70% of the line where the TCSCs located.

VI. SIMULATION RESULTS & DISCUSSION

The power flow results before TCSCs allocation shows that **line 6-8 (P_{6-8}) is more than its rated value (P_{rated}) by 18.5%**. After allocation of TCSCs using WOA, Active power flowing in line 6-8 (P_{6-8}) **returns to 93.875%** of its rated value (P_{rated}) and **the minimum voltage of the system increased from 0.944 to 0.95**. On the other hand, the power flow results after allocation of TCSCs using MINLP method, Active power flowing in line 6-8 **returns to 100%** of its rated value and **the minimum voltage of the system increased from 0.944 to 0.95**. Figures from figure 8 to figure 10 showed (P/P_{rated}) percentage of power flowing in line 6-8 from its rated value, system's minimum voltage (V_{min}) and system's total active loss (P_{Loss}) before and after TCSCs allocation compared with those obtained in [17].

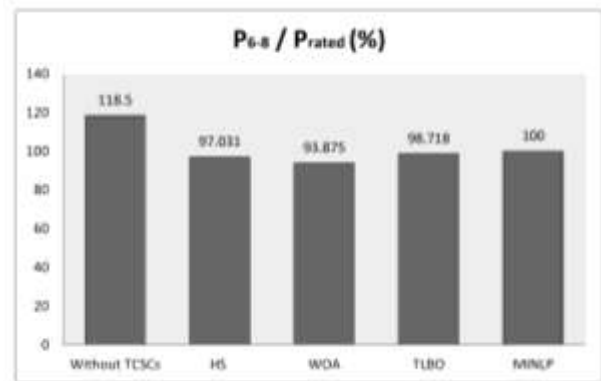

Fig. 8 shows (P/P_{rated}) percentage of power flowing in line 6-8

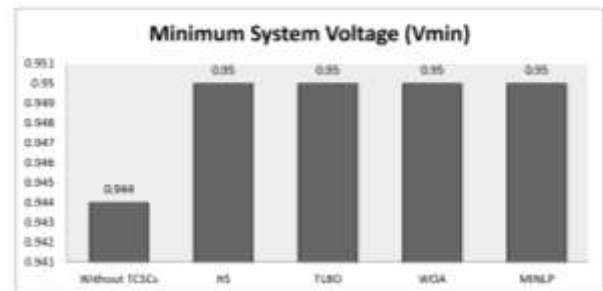

Fig. 9 Minimum System Voltage

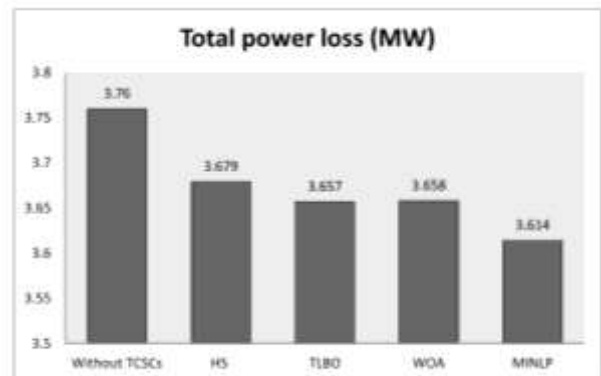

Fig. 10 Total active power loss

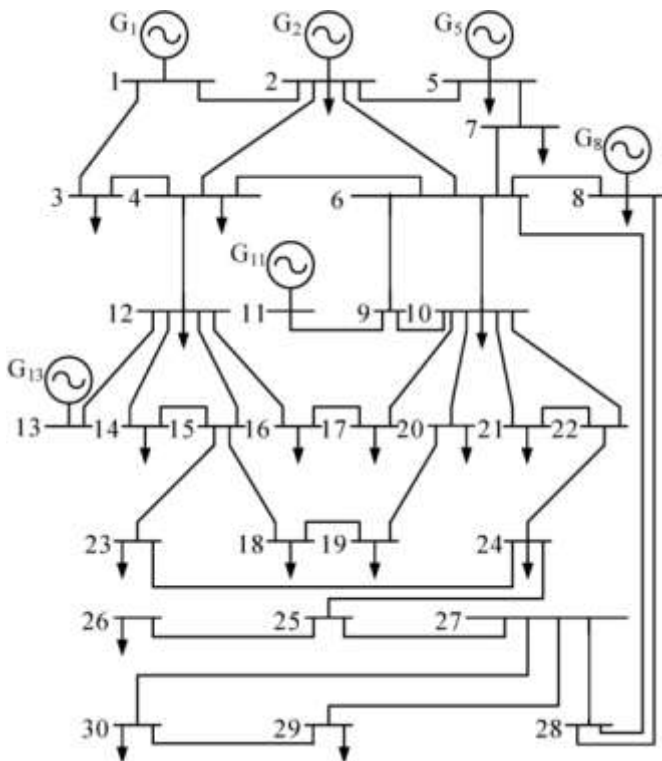

Fig. 7. IEEE 30 bus system

From the previous analysis, it can be noticed that small improvements achieved after allocating 12 TCSC devices when applying WOA and 16 TCSC devices when applying MINLP which are significantly large. The maximum reactive power loss when using WOA and MINLP is lower than that obtained in [17]. Another effective technique was mentioned in [17] by choosing only the lines which are far from its rated value and check the lines around it. It is found out that 6 possible locations to allocate TCSCs, those locations are lines (4-6, 2-6, 6-7, 6-8, 6-28, and 8-28) after excluding lines connected to transformers and they are (6-9 and 6-10). After running the WOA algorithm program with the 8 possible locations, it was found that only 2 devices are needed in order to restore system stability rather than 12 devices in the previous results. On the other hand, after running the MINLP



program with the 8 possible locations, it was found that only 2 devices are needed in order to restore system stability rather than 16 devices in the previous results. TCSCs compensation levels and locations are given in table 1. the voltage at bus 8 (minimum system voltage) was 0.944 without TCSCs allocation. The voltage at bus 8 (minimum system voltage) was 0.944 without TCSCs allocation. After TCSCs allocation using WOA, voltage at bus 8 raised to 0.948 in the case of minimum voltage limit of the system is set to 0.9 p.u and also raised to 0.951 in the case of minimum voltage limit of the system set to 0.95 p.u, the power flowing in line (6-8) decreased from 118.5% to 100% in case of minimum system voltage limit set to 0.9 p.u and to 100% in case of minimum system voltage limit is set to 0.95 p.u. After TCSCs allocation using MINLP, voltage at bus 8 raised to 0.948 in the case of minimum voltage limit of the system is set to 0.9 p.u and also raised to 0.951 in the case of minimum voltage limit of the system set to 0.95 p.u, the power flowing in line (6-8) decreased from 118.5% to 100% in case of minimum system voltage limit set to 0.9 p.u and to 100% in case of minimum system voltage limit is set to 0.95 p.u. Table 2 shows a comparison of the system performance results before and after TCSCs allocation with those obtained in [17] after choosing the 8 possible locations of TCSC devices.

Table 1. TCSCs compensation levels and locations

Line	MINLP (V>0.9)	MINLP (V>0.95)	TLBO (V>0.9)	TLBO (V>0.95)	WOA (V>0.9)	WOA (V>0.95)	HS (V>0.9)	HS (V>0.95)
	With TCSC							
2-6	—	—	—	—	—	—	-32.64	—
4-6	-69.994	-30.665	-70	-70	-70	-30	-67.22	-69.68
6-8	—	-30	—	-70	—	-30	—	—
6-10	—	—	—	—	—	—	—	—
8-29	-59.552	-69.998	-59.55	-59.55	-59.55	-70	-59.95	-59.55
6-28	—	-69.974	—	-70	—	-70	—	—
Number of devices	2	4	2	4	2	4	3	2

Table 2. System performance analysis comparison with [17] after choosing the possible locations of TCSC

	Without TCSC	MINLP (V>0.9)	MINLP (V>0.95)	TLBO (V>0.9)	TLBO (V>0.95)	WOA (V>0.9)	WOA (V>0.95)	HS (V>0.9)	HS (V>0.95)
	With TCSC								
Actual Generation	208	207.9	207.9	207.9	207.9	207.97	207.97	207.99	207.97
Load (MW)	204.2	204.2	204.2	204.2	204.2	204.2	204.2	204.2	204.2
Vmin (p.u.)	0.944	0.948	0.951	0.948	0.951	0.948	0.951	0.95	0.948
Min. power angle (δmin)	-8.05	-7.64	-7.88	-7.64	-7.86	-7.64	-7.88	-7.66	-7.64
Qloss max (MVar)	3.41	3.42	3.41	3.42	3.41	3.42	3.41	3.41	3.42
Total loss (MW)	3.76	3.765	3.77	3.765	3.77	3.765	3.77	3.791	3.765
(P6-8 / Prated)%	118.5	100	100	100	100	100	100	99.84	100
Number of devices	-	2	4	2	4	2	4	3	2

VII. A COMPARISON BETWEEN THE PROPOSED OPTIMIZATION METHODS WITH [17]

From the comparison, it can be noticed that:

Although system improvements after allocation of TCSCs using WOA proposed optimization technique, MINLP technique and both techniques applied in [17], a large number of TCSCs devices is used. In the WOA algorithm proposed technique, It has been found that the optimum number of TCSC devices is 12 which is less than the number of devices found by TLBO & HS in [17] which makes the WOA algorithm more economic than that proposed in [17]. After considering the number of devices in the optimization process, the number of TCSC devices became 4 in the case of WOA optimization proposed technique greater than that found by HS in [17] when the optimal system voltage is set to 0.95 p.u, however, the number of TCSC devices is 2 in the case of WOA less than that found by HS in [17] by one device when the optimal system voltage is set to 0.9 p.u. . In the MINLP proposed technique, It has been found that the optimum number of TCSC devices is 16 which is less than HS in [17] which makes the MINLP method more economic than HS in [17]. The optimum number of TCSC devices when applying MINLP method is greater than the number of devices found by the TLBO in [17]. After considering the number of devices in the optimization process, the number of TCSC devices became 4 in the case of MINLP proposed technique greater than HS in [17] when the optimal system voltage is set to 0.95 p.u, however, the number of TCSC devices is 2 in the case of MINLP proposed technique less than that found by HS in [17] by one device when the optimal system voltage is set to 0.9 p.u.

VIII. CONCLUSION

In this paper a classical optimization technique (MINLP) and other artificial intelligence technique (WOA) are proposed to find optimal location and sizing of FACTS devices to minimize power loss. Results were compared with other optimization techniques. Results obtained has shown the superiority of the MINLP classical optimization technique against all the new heuristic optimization techniques in finding the optimum solution, however WOA has proven it is superiority in finding a techno-economic solution to the problem through finding lower number of devices in the first case study.

V. REFERENCE

[1] F. G. M. Lima, F. D. Galiana, I. Kockar and J. Munoz, "Phase shifter placement in large-scale systems via mixed integer linear programming", *IEEE Transactions Power Systems*, vol. 18, no. 3, pp. 1029-1034, Aug. 2003.

[2] A. berizzi, M. Delfanti, P. Marannino, M. S. Pasquadibisceglie and A. Silvestri, "Enhanced security-constrained OPF with FACTS devices", *IEEE*



- Transactions Power Systems*, vol. 20, no. 3, pp. 1597-1605, Aug. 2005.
- [3] J. A. Momoh and J. Zhu, "Multi-area power systems economic dispatch using nonlinear convex network flow programming", *Electric Power System Research*, vol. 59, pp. 13-20, 2001.
- [4] A. K. Sharma, "Optimal number and location of TCSC and loadability enhancement in deregulated electricity markets using MINLP", *International Journal of Emerging Electric Power System*, vol. 5, issue. 1, pp. 1-13, 2006.
- [5] Whei-Min Lin, S-J. Chen and Y.S Su, "An application of interior point based OPF for system expansion with FACTS devices in a deregulated environment", *0-7803-6338-8/00/\$10.00 © 2000 IEEE*, pp. 1407-1412.
- [6] Weerakorn Ongsakul and Peerapol Jirapong, "Optimal allocation of FACTS devices to enhance total transfer capability using evolutionary programming", *IEEE International Symposium on Circuits and Systems, ISCAS*, vol. 5, May 2005, pp. 4175-4178.
- [7] T. S. Chung and Y. Z. Li, "A hybrid GA approach for OPF with consideration of FACTS devices", *IEEE Power Engineering Review*, pp. 47-50, Feb. 2001.
- [8] A. Y. Abdelaziz, M. A. El-Sharkawy, M. A. Attia, "Optimal Location of Thyristor-controlled Series Compensators in power Systems for Increasing Loadability by Genetic Algorithm", *Electric Power Components and Systems*, pp. 1373-1387, 2011, © Taylor & Francis Group, LLC.
- [9] M. Saravanan, S. M. R. Slochanal, P. Venkatesh, J. P. S. Abraham, "Application of particle swarm optimization technique for optimal location of FACTS devices considering cost of installation and system loadability", *Electric Power Systems Research*, vol. 77, pp. 276-283, 2007.
- [10] L. J. Cai, I. Erlich and G. Status, "Optimal choice and allocation of FACTS devices in deregulated electricity market using genetic algorithms", *0-7803-8718-X/04/\$20.00 © 2004 IEEE*.
- [11] Seyedali Mirjalili and Andrew Lewis, "The Whale Optimization Algorithm", *Advances in Engineering Software*, vol. 95, pp. 51-67, 2016
- [12] Watkins WA , Schevill WE, "Aerial observation of feeding behavior in four baleen whales: *Eubalaena glacialis* , *Balaenoptera borealis* , *Megaptera novaeangliae* , and *Balaenoptera physalus*" *J Mammal*, pp.155-63, 1979.
- [13] R. J. Dakin, "A Tree-Search Algorithm for Mixed Integer Programming Problems", *Computer Journal* 8, pp. 250-255, 1965.
- [14] A. Land, A. Doig, "An Automatic Method of Solving Discrete Programming Problems", *Econometrica* 18, vol. 3, pp. 454-461, 1970.
- [15] E. L. Lawler, D. E. Wood, "Branch and Bound Methods: A Survey", *Operations Research* 14, vol. 4, pp. 699-719, 1966.
- [16] Zimmerman, R.D., Murillo-Sanchez, E.C.: *Matpower A Matlab™ Power System Simulation Package Version 3.2, User's Manual* (September 21, 2007).
- [17] Ibrahim M. Diao, Niveen M. Badra, Mahmoud A. Attia, "Harmony Search Algorithm and Teaching-Learning-Based Optimization Approaches to Enhance Power System Performance", © *IDOSI, World Applied Sciences Journal*, vol. 34, No. 10 pp. 1357-1365, November 2016

IJEAST

INTERNATIONAL JOURNAL
OF ENGINEERING APPLIED SCIENCE
AND TECHNOLOGY

ABOUT IJEAST

International Journal of Engineering Applied Science and Technology (IJEAST) is a peer-reviewed, open access journal that publishes high-quality research papers in the field of Engineering, Applied Science and Technology.

IJEAST aims to provide a platform for researchers, academicians, and professionals to share their innovative ideas, research findings, and practical experiences with the global scientific community.

FOCUS AREAS

- Engineering
- Applied Science
- Technology
- Innovation & Development
- Interdisciplinary Studies



PEER REVIEWED

All submissions are rigorously peer reviewed to ensure quality.



OPEN ACCESS

Free and unrestricted access to research for all.



GLOBAL REACH

Connecting researchers and professionals worldwide.



TIMELY PUBLICATION

We ensure a swift and efficient publication process.



For more information, visit our website

www.ijeast.com



INTERNATIONAL JOURNAL
OF ENGINEERING APPLIED SCIENCE
AND TECHNOLOGY

✉ editor@ijeast.com

🌐 www.ijeast.com

📍 India



2455-2143