



# IJEAST

INTERNATIONAL JOURNAL  
OF ENGINEERING APPLIED SCIENCE  
AND TECHNOLOGY



**VOLUME : 4    ISSUE : 09    Print / Issue Publication Date: 10-Mar-2020**



**ISSN : 2455-2143**



**DOI : 10.33564/IJEAST.2020.v04i09.032**

Indexed In



[WWW.IJEAST.COM](http://WWW.IJEAST.COM)

[editor@ijeast.com](mailto:editor@ijeast.com)



# DESIGN AND FABRICATION OF BALLOON SATELLITE

Rokeshuvaraj N

Department of Aerospace Engineering  
Alliance College of Engineering and Design  
Alliance University  
Bangalore, Karnataka, INDIA

Cholasamudram Sai Pavan Reddy

Department of Aerospace Engineering  
Alliance College of Engineering and Design  
Alliance University  
Bangalore, Karnataka, INDIA

Vivek D

Department of Aerospace Engineering  
Alliance College of Engineering and Design  
Alliance University  
Bangalore, Karnataka, INDIA

Vijayalakshmi Bharathi K

Department of Aerospace Engineering  
Alliance College of Engineering and Design  
Alliance University  
Bangalore, Karnataka, INDIA

**Abstract-** The objective of this research is to know, study and visualize (1) about the atmospheric parameters, temperature, density, pressure at various altitudes of the earth atmosphere within the region from sea level to thirty-five kilometers altitude above; (2) the horizon of the Earth atmosphere; ozone layer presence and concentration of ozone gas at different altitudes; (3) the shape of the water molecules in the clouds; (4) the global warming gasses concentration in various regions of atmosphere; (5) the moisture concentration at various regions of earth atmosphere; (6) to calibrate the theoretical data and to understand the concept of fluid separation. A satellite system is made with the help of raspberry pi as the main computer to find the physical properties such as temperature, pressure, moisture percentage chemical properties such as carbon dioxide concentration, ozone concentration and attributes such as altitude and sky images; then the system is placed in a heat insulation chamber with all the sensors exposed to the atmosphere and the main system in the center. The system is now fixed to a latex balloon filled with helium gas. The setup is lifted due to buoyancy and at a certain point in time when the balloon expands at around 35000m the balloon explodes and the satellite starts to fall, the parachute gets ejected and the satellite makes a soft land to the ground, with the help of the position information transmitted by GPS, the satellite is tracked down and the recorded readings are tabulated and analyzed.

All of the studies that provide information to the students rely on theoretical data and in a few cases practical data. In the field which deals with the earth atmosphere, all the data is of theoretical or an average but the atmospheric conditions differ from place to another place due to the variation in geographical conditions, celestial conditions, and environment conditions; the atmospheric conditions at one region can't be same as that of the other region. The variable parameters can be temperature, pressure, density, moisture percentage, chemical composition and so on. When the theoretical data are used instead of practical data as the base to find the effective parameters there will be errors and if these errors come in the governing of the people or living life, they can cause catastrophic damage.

The presence of ocean or any other water bodies can cause an increase in the basicity or PH value of the region; similarly, in the case of deserts, there will be a very high temperature because of its geographical conditions and in the case of rain forests and evergreen forests there will be an increase in acidity and decrease in temperature, these induce effects in the materials such as corrosion, ionization, and conductivity.

The damage to the materials can be avoided by carefully examining the environment and selecting suitable elements such as steel which gets easily corroded in freshwater than in saline water. This careful selection of materials will be done by examining the electronegativity scale of the materials to avoid corrosion, by this the life period of the system can be increased. The environmental conditions that need to be considered for securing any material are Acidity and Basicity, Moisture Percentage, Temperature and else;

## I. INTRODUCTION

In the case of aerospace which deals with the aerodynamics which is an entire study of atmospheric properties, a small error can cause a huge catastrophe, if it's a manned flight the flight can be controlled and stabilized by the careful judgment of the pilot but the same can't be said to rockets and missiles because they are unmanned and the autopilot cannot make any decisions when the sensors show errors in the readings so it's necessary to make a pre-launch and a pre-flight check.

All of this can't be found theoretical, nor by satellite imaging and satellite data processing so it's necessary to experiment to find out the atmospheric conditions within the level of operation, this will ensure safety, easy mobility, swiftness, and so-on. This is done in the defense field and also in the space fields, here they monitor the weather conditions and make the precession corrections before they launch any rockets and missiles or perform National Security Operations.

## II. MATERIALS

The following are the list of materials used in the formation of the satellite system.

1. Raspberry Pi Model B+ RASP-PI-3
2. BE-000318 [3.5" Touch Screen LCD Display]
3. ASIN: B07JHP1T9K [Multicamera Adapter Module for Pi.]
4. BMP180 Barometer [Pressure Sensor]
5. DHT22 [Humidity Sensor]
6. MQ2 [Gas Sensor]
7. Mikroe Ozone 2 click - MQ131 [Ozone Gas Sensor]
8. MQ 7 [Carbon Monoxide Sensor]
9. Vk-162 G-Mouse.
10. 5MP OV5647 Sensor Adjustable Wide Fisheye lens Night Vision Camera
11. Raspberry Pi Infrared IR Night Vision Surveillance Camera Module 500W Webcam
12. Aluminum Case with Cooling System.
13. M-M, F-F, M-F Jump Wires.
14. Raspberry Pi Camera 15pin Extension cable.
15. Micro DC Centrifugal Pump.
16. Heating Pad.
17. Breadboard
18. 9V Battery With Battery Clip.
19. 20000 mah Lithium-Ion Battery.
20. Silicon Oxygen Tube.
21. Tube Splitter
22. Parachute.
23. Aluminum Foil.
24. Depron Sheet.
25. Styrofoam.
26. Thermocol.

27. Fishing Line.
28. Meteorological Balloon
29. Helium Cylinder 25 kg.
30. Springs.
31. Two-Sided Stick Tape.
32. SD Card
33. Card Reader
34. HDMI Cable

### 2.1. Raspberry Pi Model B+ RASP-PI-3



Fig 2.1.1: Raspberry Pi 3B+ [1]

This motherboard from Raspberry Pi features 4 USB ports, an HDMI port, and a 3.5mm audio jack, among other features. It has a faster 64-bit 1.4GHz quad-core processor, 1GB of RAM, faster dual-band 802.11 b/g/n/ac wireless LAN, Bluetooth 4.2, and significantly faster 300Mbit/s ethernet. The motherboard also features a micro SD card slot. The micro SD card slot follows a push-pull technique.

It has the following specifications:

1. 1.4GHz 64-bit quad-core ARM Cortex-A53 CPU (BCM2837).
2. 1GB RAM (LPDDR2 SDRAM).
3. On-board wireless LAN - dual-band 802.11 b/g/n/ac (CYW43455).
4. On-board Bluetooth 4.2 HS low-energy (BLE) (CYW43455).
5. 4 x USB 2.0 ports.
6. 300Mbps gigabit ethernet over USB 2.0.
7. 40 GPIO pins.
8. Full-size HDMI 1.3a port.
9. Combined 3.5mm analog audio and composite video jack.
10. Camera interface (CSI).
11. Display interface (DSI).
12. microSD slot.
13. Video Core IV multimedia/3D graphics core @ 400MHz/300MHz.

**Quad-Core CPU**

This motherboard from Raspberry Pi features a 1.4GHz 64-bit quad-core ARMv8 processor. The quad-core processor is a chip with four cores, which process general computing at a smooth rate. This comes in handy when you work with big files and switch between applications oftentimes, as it fastens up the computer performance. The ARMv8 processor, can run the full range of ARM GNU/Linux distributions, including Snappy Ubuntu Core, as well as Microsoft Windows 10 IoT edition.

**Four USB Ports**

The motherboard features four USB ports. You can connect your pen drive, digital accessories like display. It can also be used as a charging socket

**2.2. BE-000318 [3.5" Touch Screen LCD Display]**



Fig 2.2.1: Touch Screen LCD Display [1]

This little 3.5-inch contact screen module is planned particularly for Raspberry Pi, utilizing the most recent Linux Core framework. This is perfect for DIY anywhere, whenever and doesn't require any different force source or case to hold it. The module sits directly over Pi and a perfect elective answer for HDMI screens. The screen likewise accompanies a stylus to collaborate with the little screen.

It is required to utilize an independent 5V/2A power connector, in light of the fact that the PC's USB port may have insufficient capacity to help both Pi and LCD

**Specifications:**

1. Designed for Raspberry Pi, a perfect elective answer for HDMI screen
2. Supports all correction of Raspberry Pi (legitimately pluggable models)
3. Works with Raspbian/Ubuntu legitimately

4. Comes with a full arrangement of screws and nuts for holding together

5. 320×480 goals, better presentation

6. Lightweight and simple to introduce

LCD Type	TFT
Interface	SPI
Touch Screen Type	Resistive Screen
Touch Controller	XPT2046
Colors	65536
Backlight	Yes, LED
Resolution (Pixel)	320*480
Aspect Ratio	8:5
Dimensions (L*W*H)	85 * 55 * 17 mm
Weight	60 gm

**2.3. ASIN: B07JHP1T9K [Multicamera Adapter Module for Pi.]**



Fig 2.3.1: Multicamera Adapter Module for Pi [1]

Arducam B0120 ASIN: B07JHP1T9K Raspberry Pi multi-camera connector module is intended for interfacing more than one camera to a solitary CSI camera port on Raspberry Pi board. One connector board can associate 4 cameras and the user can pile up a limit of 4 connector barricades that way to 16 cameras on a solitary Raspberry Pi board. Suit 4 Raspberry Pi cameras on a multi-camera connector board Stackable and greatest course 4 connector sheets 3 GPIOs required for multiplexing on one connector board, 5 GPIOs for two connector board, 9 GPIOs for four connector board. All camera ports have FFC (adaptable level link) connectors DIP switches for a

simple stack up the setup. It underpins Raspberry Pi A/B/B+ and Pi 2.

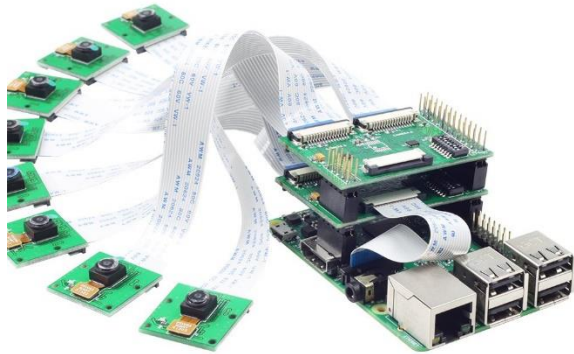

Fig 2.3.2: Camera Connections [1]

Pin Configuration:

Plunge switches are utilized here for simple stack up design. At the point when only one multi-camera connector board is utilized, the switches 1 and 5 ought to be changed to ON position. On the off chance that two-multi camera connector sheets are utilized, the drawback board ought to be changed 1 and 5 to ON and upside board ought to be changed 2 and 6 to ON position, and if 3 or 4 multi-camera connector sheets are utilized together each board layer ought to be designed as appeared.



Stacking Layer	Selection	Enable 1	Enable 2	DIP Switch Configuration
1	Pin 7	Pin 11	Pin 12	
2	Pin 7	Pin 15	Pin 16	
3	Pin 7	Pin 21	Pin 22	
4	Pin 7	Pin 23	Pin 24	

Fig 2.3.3: Pin Configuration of Multicamera Adapter Module [1]

2.4. BMP180 Barometer [Pressure Sensor]

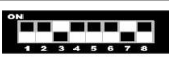
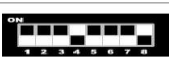
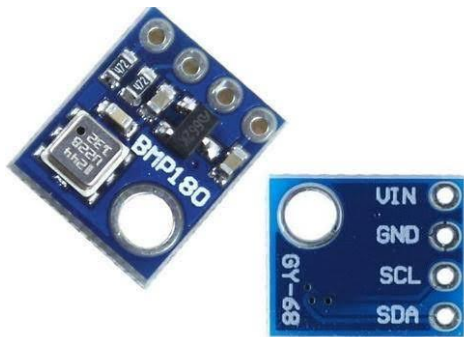

Fig 2.4.1: Pressure Sensor [1]

The BMP180 is an i2c board, which implies that it utilizes the i2c (articulated 'eye two see' or 'eye squared see') convention to speak with the Raspberry Pi. The benefit of i2c is that it just uses two pins on the Raspberry Pi (in addition to power and ground) to speak with many gadgets. One pin conveys a clock signal, and different conveys the information.

The main thing you have to do is design the Raspberry Pi to utilize i2c. Simon Monk has composed generally excellent guidelines about how to set up Raspberry Pi to have the option to utilize i2c on the Adafruit site.

Connecting the BMP180:

To interface BMP180 to Raspberry Pi, you will require a breadboard and four female to male jumper wires. It is in every case best to kill your Raspberry Pi before associating anything to it, so issue the accompanying and trust that the green light will go off.

Follow the outline beneath to associate the BMP180 to Raspberry Pi with the assistance of Jumper wires. There are a couple of various plans for the BMP180 sheets. The BMP180 alludes to the chip, not simply the entire board, so you may find that your board has 4, 5 or six pins.

The red jumper goes from the 3v3 (3.3-volt power supply) pin of the Raspberry Pi to the VCC pin of the BMP180. The yellow jumper goes from the second pin from the privilege on the top line of the Raspberry Pi to the SDA pin of the BMP180. The BMP180 utilizes this wire to speak with the Raspberry Pi. The blue jumper goes from the third pin from the privilege on the top column of the Raspberry Pi to the SCL pin of the BMP180. This pin supplies a clock signal (it turns on and off at ordinary interims) that is utilized by i2c gadgets to time their correspondence to the Raspberry Pi. The dark jumper goes from any of the ground (GND) pins of the Raspberry Pi to the GND nail to the BMP180.

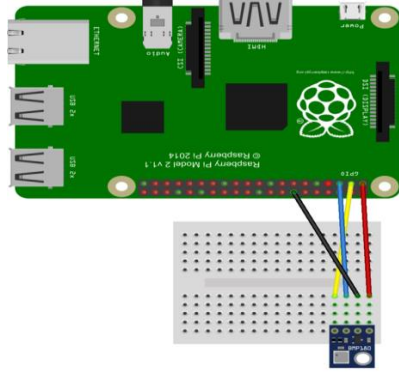

Fig 2.4.2: Connection Configuration [1]

**Features:**

- It can measure temperature and height.
- Pressure sensing range: 300 to 1100hPa.
- High relative accuracy of  $\pm 0.12$ hPa.
- It can work at low voltages.
- 3.4Mhz I2C interface.
- Low power consumption (3uA).
- Pressure transformation time: 5msec.
- Small in size.

**Specifications:**

- Operating voltage: 1.3V to 3.6V.
- Input voltage: 3.3V to 5.5V.
- Peak current: 1000uA.
- Standby current 0.1uA.
- Maximum voltage at SDA, SCL: VCC + 0.3V.
- Operating temperature: -40°C to +80°C.

**2.5. DHT22 [Humidity Sensor]**

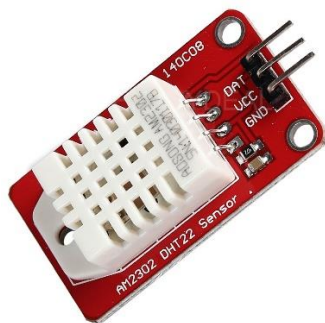

Fig 2.5.1: Humidity Sensor [1]

The DHT11 and DHT22 sensors can measure humidity as well as temperature. Only one GPIO is used. The difference between the two is mainly the

measuring range and accuracy. The white DHT22 can measure all humidity ranges from 0-100% with an accuracy of 2%. By comparison, the DHT11 (blue) is only able to measure areas of 20-90% humidity and above all, the accuracy is significantly worse with 5%.

The DHT22 is a basic, low-cost digital temperature and humidity sensor. It uses a capacitive humidity sensor and a thermistor to measure the surrounding air and spits out a digital signal on the data pin (no analog input pins needed). It's fairly simple to use but requires careful timing to grab data. The only real downside of this sensor is you can only get new data from it once every 2 seconds.

**Plugging in the DHT22:**

Simply connect the first pin on the left to 3-5V power, the second pin to your data input pin and the rightmost pin to ground. Although it uses a single-wire to send data it is not Dallas One Wire compatible! If you want multiple sensors, each one must have its data pin.

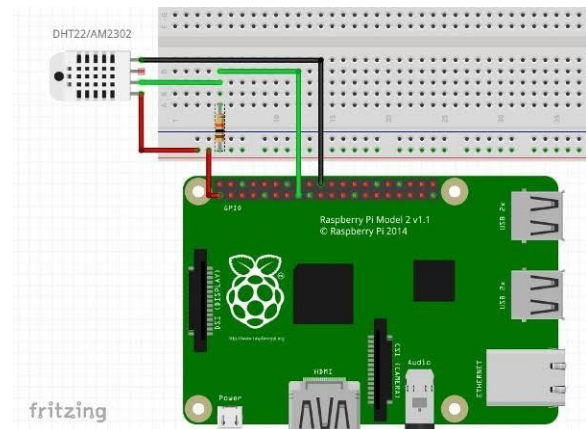

Fig 2.5.2: Connection Configuration [1]

**Specifications:**

- Can measure Temperature and Humidity.
- Temperature range: -40 to 125°C,  $\pm 0.5^\circ\text{C}$  accuracy
- Humidity range: 0-100%, 2-5% accuracy
- Potable size

**Features:**

- I/P Voltage: 3 to 5V

- I/P Current: 2.5mA max current use during conversion.
- No more than 0.5 Hz sampling rate (once every 2 seconds)
- Body size 27mm x 59mm x 13.5mm (1.05" x 2.32" x 0.53")
- 4 pins, 0.1" spacing
- Weight: 2.4g

For module		
1	Vcc	Power supply 3.5V to 5.5V
2	Data	Outputs both Temperature and Humidity through serial Data
3	Ground	Connected to the ground of the circuit

### 2.6. MQ2 [Gas Sensor]



Fig 2.6.1: MQ2 Gas Sensor [1]

The Grove - Gas Sensor (MQ2) module is useful for gas leakage detection (home and industry). It is suitable for detecting H<sub>2</sub>, LPG, CH<sub>4</sub>, CO, Alcohol, Smoke or Propane. Due to its high sensitivity and fast response time, the measurement can be taken as soon as possible. The sensitivity of the sensor can be adjusted by the potentiometer.

Connection:

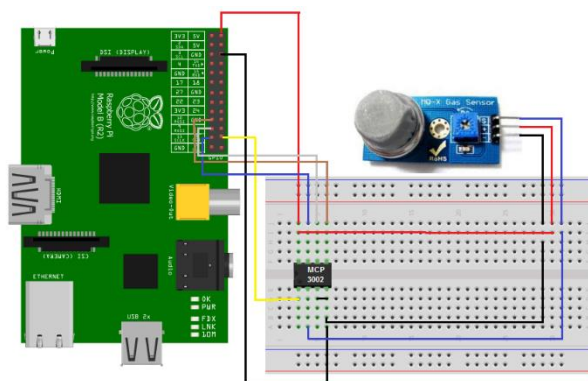

Fig 2.6.2: Connection Configuration [1]

Specifications:

- I/P Voltage, Vin: 3 to 5VDC
- -40 to +85°C operational range, +/- .5ppm accuracy.
- This board/chip uses I2C 7-bit address 0x77.
- Working voltage, Vcc: 4.9 to 5.V
- Heating consumption, PH: 0.5 to 800mW
- Load resistance, RL: adjustable
- Heater resistance, RH: 33 ohm
- Sensing Resistance, Rs: 3 to30 K-ohm

Features:

- Wide detecting scope
- Stable and long lifetime.
- Fast response and high sensitivity

### 2.7. Mikroe Ozone 2 click - MQ131 [Ozone Gas Sensor]



Fig 2.7.1: MQ131 Ozone Sensor [1]

MQ131 uses the SnO<sub>2</sub> alloy as the base material, which decreases resistance when exposed to the O<sub>3</sub> gas. The greater the O<sub>3</sub> concentration is, the more conductive this material becomes. This can be utilized to obtain the O<sub>3</sub> concentration readings. The sensor itself contains a small heating element, connected to the 5V power supply. It needs to be preheated for 48h before it can perform as specified. The sensitivity of the sensor is given as the ratio between the resistance in air and the resistance in the O<sub>3</sub> gas concentration of 50ppm, which is  $\geq 3$  ( $R_0/R_S \geq 3$ ). The sensor is protected against particles and mechanical damage by a stainless mesh, however, exposure to excessive moisture and corrosive gases can damage the inner structure.

Connection:

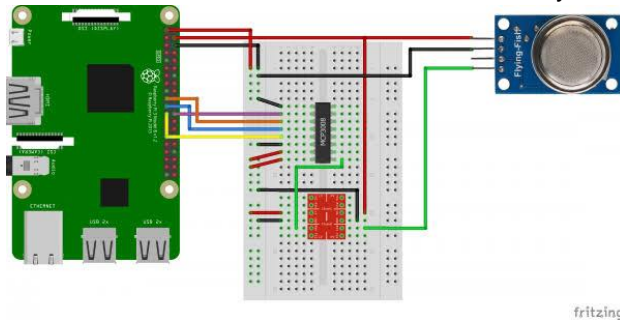

Fig 2.7.2: Connection Configuration [1]

Specifications:

- Can measure Ozone concentration for air quality control.
- Potable size

Features:

- I/P Voltage: 3.3 to 5VDC
- Ozone detection range: 10-1000ppm
- Error: ±6
- On board modules: MQ131 sensor, MCP3551
- Body Size: 57.15mm x 25.4mm

2.8. MQ 7 [Carbon Monoxide Sensor]

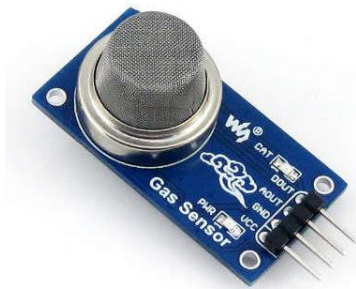

Fig 2.8.1: MQ7 Carbon Monoxide Sensor [1]

The MQ7 gas sensor detects the concentrations of CO in the air and outputs its reading as an analog voltage. The sensor can measure concentrations of range 10 to 10,000 ppm. The sensor can operate at temperatures from -10 to 50°C and consumes less than 150 mA at 5 V.

Connection:

Connecting five volts across the heating (H) pins keeps the sensor hot enough to function correctly. Connecting five volts at either the A or B pins causes the sensor to emit an analog voltage on the other pins. A resistive load between the output pins and ground sets the sensitivity of the detector. The resistive load should be calibrated for your particular application using the equations in the datasheet, but a good starting value for the resistor is 10 kΩ.

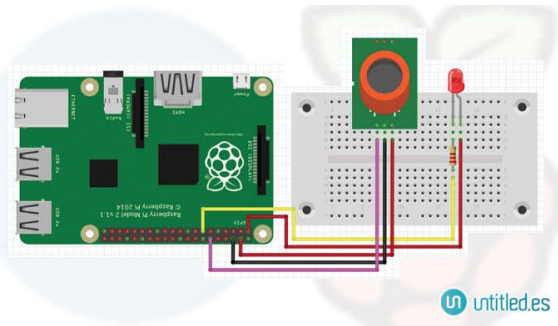

Fig 2.8.2: Connection Configuration [1]

2.9. Vk-162 G-Mouse



Fig 2.9.1: G-Mouse [1]

The Mini G-mouse Vk-162 GPS Receiver (USB) is a low-cost High sensitivity GPS Receiver + Internal Antenna with USB connector. It is a Stand-alone GPS receiver providing a solution with high position and speed accuracy performances as well as high sensitivity and tracking capabilities in urban conditions. Just plug the module to your LAPTOP and you will get GPS data in Standard NMEA Protocol format (NMEA 0183).

The Mini G-mouse contains a magnetic plate that helps you to place the G-mouse on any metal plates to get a clear view of the sky. It has a very compact and easy to integrate design with the ultimate tracking performances. The GPS chipsets inside the module are

designed by LOCUSY. The module provides current time, date, latitude, longitude, speed, altitude and travel direction / heading among other data, so it can be used in a host of applications, including navigation, tracking systems, fleet management, mapping, and robotics.

Features:

- Built-in Ublox G6010 / G7020 Low power consumption GPS chipset.
- 50 channel GPS L1 frequency C/A Code.
- Superior sensitivity up to -162dBm.
- Built-in WAAS/EGNOS/MSAS Demodulator without any additional hardware.
- Low power consumption.
- Waterproof design.
- USB interface with 2m long cable.
- Magnetic Fix

Specifications:

- Chipset properties:
  - Main chip: Ublox 6010 / 7020
  - C / A code: 1.023MHz stream
  - Receive frequency: L1 [1575.42MHz]
  - Tracking Channels: 50
  - Support DGPS [WAAS, EGNOS and MSAS]
- Positioning performance
  - 2D plane: 5m [average]
  - 2D plane: 3.5m [average], there DGPS auxiliary.
  - Drift: <0.02m / s
  - Timing Accuracy: 1us
  - Reference coordinate system: WGS-84
  - Maximum altitude: 18,000 m
  - Maximum speed: 500m / s
  - Acceleration: <4g
- Electrical properties:
  - Tracking sensitivity: 162dBm
  - Acquisition sensitivity: 148dBm
  - Cold start time: 32s [average]
  - Warm start: 32s [average]
  - Hot start time: 1s [average]
  - Recapture Time: 0.1s [average]
- Temperature
  - Operating: -40°~ 80°C
  - Storage: -40°~ 85°C
  - Humidity: Up to 95% non-condensing
- Protocol:
  - GPS Protocol Default: NMEA 0183
  - GPS Output Data: Command GGA, GSA, GSV, RMC, VTG, GLL
  - GPS transfer rate: Auto-Baud

- Dimensions:
  - Dimension: 49 \* 38 \* 16mm
  - USB Cable length: 2m

## 2.10. 5MP OV5647 Sensor Adjustable Wide Fish eye lens Night Vision Camera



Fig 2.10.1: Fish Eye Lens Night Vision Camera [1]

5MP OV5647 Sensor is a High Quality, great performance with a robustly built quality camera. The camera has Adjustable Wide-Angle Fish-eye Lens with Night Vision mode capable of 2592 x 1944-pixel static images and also supports 1080 p @ 30 fps, 720 p @ 60 fps and 640 x480 p 60/90 video recording.

An adjustable focus can be manually adjusted according to the distance of the object. With 5MP OV5647 webcam sensor, 222-degree FOV, the vision is extremely open. This is a fisheye wide-angle camera for Raspberry pi 2 Raspberry pi 3B and 3B+, applicable occasions VR, AR, aerial photography, real-time photography of the car, indoor and outdoor monitoring, photographing and video recording.

Connection:



Fig 2.10.2: Connection Configuration [1]

Features:

- Wide-angle fish eye lens
- Manual Adjustable Focus
- Easy to install and use
- Useful for real-time photography and videos

#### 2.11. Raspberry Pi Infrared IR Night Vision Surveillance Camera Module 500W Webcam



Fig 2.11.1: IR Camera [1]

This Raspberry PI Infrared IR Night Vision Surveillance Camera Module 500W Webcam is useful in daylight as well as in the darkness of night also.

It features 5MP with Omni Vision 5647 sensor which is in fixed focus mode. The 5MP camera module is perfect for small Raspberry Pi projects which have very little space allowance just boot up the latest version of Raspbian and you are good to go!!!

The high-definition 5MP camera delivers outstanding photos but can also shoot video, ideal for drones or a CCTV project. The camera overcomes the disadvantages offered by our other Raspberry Pi Cameras as it has provision for night surveillance too.

This Raspberry Pi Camera Module is a custom designed add-on for Raspberry Pi. It attaches to Raspberry Pi by way of one of the two small sockets on the board upper surface. This interface uses the dedicated CSI interface, which was designed especially for interfacing with cameras. The CSI bus is capable of extremely high data rates, and it exclusively carries pixel data.

It connects to Raspberry Pi by way of a short flexible ribbon cable. The camera connects to the BCM2835 processor on the Pi via the CSI bus, a higher bandwidth link that carries pixel data from the camera back to the processor. This bus travels along the ribbon cable that attaches the camera board to the Pi.

Features:

- This camera can also work at night.
- Supported Video Formats: 1080p @ 30fps, 720p @ 60fps and 640 x 480p 60/90 video
- Fully compatible with Raspberry Pi Model B
- Small and lightweight

#### 2.12. Aluminum Case with Cooling System.



Fig 2.12.1: Aluminum Case with Cooling System [1]

A solid aluminum case is used as a frame to give grip and support to the components, it's also fixed with a cooling system consisting of heat exchangers and an exhaust fan for maintaining the temperature of the boards and the circuits within. It also helps to maintain

the structure and transfer the impact load without affecting the devices within.

multi-camera adapter to the camera's [IR Cameras and Fish Eyed Lens Night Vision Cameras].

### 2.13. M-M, F-F, M-F Jump Wires.



Fig 2.13.1: Jumper Wires [1]

A jump wire (also known as jumper wire, or jumper) is an electrical wire, or group of them in a cable, with a connector or pin at each end (or sometimes without them – simply "tinned"), which is normally used to interconnect the components of a breadboard or other prototype or test circuit, internally or with other equipment or components, without soldering. Individual jump wires are fitted by inserting their "end connectors" into the slots provided in a breadboard, the header connector of a circuit board, or a piece of test equipment.

### 2.14. Raspberry Pi Camera 15pin Extension cable. [B07LFQQWWG]



Fig 2.14.1: 15pin Camera Extension Cable [1]

These are the extension cables for camera's connected to Raspberry Pi, it is a white cable of 100cm length with a 15pin configuration, the cable has blue tips. It runs from the ASIN: B07JHP1T9K which is the

### 2.15. Micro DC Centrifugal Pump.



Fig 2.15.1: Micro Pump [1]

The micro or mini pump is a centrifugal pump, it runs on a power supply of 4-9V. It consumes a direct current of .4 - 1.5W and has a flow rate of 120liters/hour; with a forced capillary lift capacity of 1.1m.

Features:

- Weight: 90grams
- Size: 45 x 24 x 30mm
- Submersible
- Current Consumption: 220mA

### 2.16. Heating Pad



Fig 2.16.1: Heating Pads [1]

It is a heating medium with good flex resistant, washable, good stability, simple and convenient, environmentally friendly, safe and non-toxic. It is made up of carbon fiber, nonwoven fabric and silica gel line with a size of 18\*10cm operating at an input voltage of five. The power supply is given to it from a USB port and has a heat generation of 45 degrees. The system contains 8 pads connected to a single USB port. The working time of the system depends upon the power supply on average it can work for about 6 hours for 10000mah battery supply.

Specifications:

- Colour: Black
- Power: 8-8.5W
- Maximum voltage: 5 to 7.4V
- Power requirements: 5V 2A

#### 2.17. Breadboard



Fig 2.17.1: Breadboard [1]

This 170 tie points (17 x 5 x 2 points) breadboard is compatible to prototype DIP IC's, resistors, transistors, diodes, led, capacitors pots and other types of electronic components. With the self-adhesive tape on the back, it's easy to stick on the platform, such as a solid platform.

Each row and columns have corresponding letters and numbers. With tight plug-in contacts, the components will sit well after assembly, no wobbles. It's easy to insert and remove jumper wires from the breadboard.

The outer frame is made up of ABS plastic and all the internal connections are made from tin, phosphor, bronze nickel alloy. The component has good abrasion and corrosion resistance.

The solderless breadboards do not require soldering and are reusable. It is suitable for the prototypes and circuit design experiments, teaching and other DIY projects.

Specifications:

- Weight: 49.9 grams
- Pins: 170, 17 in a row
- Size: 47 x 35 x 8.5mm
- Phosphor, bronze, nickel-plated spring clips

#### 2.18. 9V Battery with battery clip.



Fig 2.18.1: 9V Battery with battery clip [1]

9V hi-watt battery with battery clip is a high capacity and low-cost solution for many electronic devices, it is used with its specific battery snap, connector or clip. The battery clip can be used to power leads or other devices with a 9v battery. Here it is used to give power supply to the micropump.

#### 2.19. 20000 mah Battery.

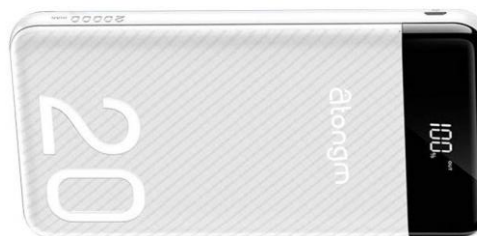

Fig 2.19.1: 20000 mah Battery [1]

A lithium-ion battery or Li-ion battery is a type of rechargeable battery. Lithium-ion batteries are commonly used for portable electronics and electric vehicles and are growing in popularity for military and aerospace applications.

In these batterie's lithium ions move from the negative electrode through an electrolyte to the positive electrode during discharge, and back when charging. Li-ion batteries use an intercalated lithium compound as the material at the positive electrode and typically graphite at the negative electrode. This contrasts with non-rechargeable lithium batteries, which

use metallic lithium at one of the electrodes. The batteries have a high energy density, no memory effect, and low self-discharge. They can, however, be a safety hazard since they contain a flammable electrolyte, and if damaged or incorrectly charged can lead to explosions and fires.

Specifications:

- Capacity: 20000mAh 3.7Wh
- Input parameters: 18W Max (5.0V/2.0A, 9V2A)
- Output parameters: 18W (5.1V/2.4A, 9V/2A, 12V/1.5A)
- Temperature limit: 0 to 45°C
- Output Usb ports: 2N

#### 2.20. Silicon Oxygen Tube



Fig 2.20.1: Silicon Oxygen Tube [1]

It is a transparent flexible material composed of silicon as the base material. It has high strength, flexibility and is also resistant to algae and bacteria. Its specifications are 8mm inner diameter and 10mm outer diameter. The tube is connected to the micropump, the flow is directed with the help of this tube, they end up over the heating pads.

#### 2.21. Tube splitter



Fig 2.21.1: Various Tube Splitter [1]

This is used to make connections or any splits in the flow to reduce or direct the flow to different locations. They come in many shapes, the most common type are: “-” type, “+” type, “Y” type and “T” type. With the help of these, the kinetic energy carried by the fluid can be decreased, this occurs due to the increase in pressure resistance that occurs due to the bending of flow.

#### 2.22. Parachute



Fig 2.22.1: Parachute [1]

It is a drag increasing device that helps in the safe landing of the object. It's of the circular shape of 142-centimeter diameter made up of nylon cloth of sports grade quality. The setup consists up of a clip lock that connects the satellite body to the parachute.

#### 2.23. Aluminum Foil



Fig 2.23.1: Aluminium Foil [1]

Aluminum foil is a temperature resistant foil offering pretty good resistance to the transfer of heat. It is composed of 92-99% of aluminum so we can

typically say that it is made up of only aluminum it's 0.00017 and 0.0059 inches thick. The foil we used was of 0.00070866 inches thick.

Specifications:

- Thermal conductivity: 235W/m-K
- Melting point: 650 °C
- Density: 2700 kg/m<sup>3</sup>
- Firing point: 660 °C
- Water repellent: 100%

#### 2.24. Depron Sheet



Fig 2.24.1: Depron Sheet [1]

Depron is another name for Extruded Polystyrene (XPS) closed cell foam in sheet form, It is a fantastic material for building model aircraft, and also a popular material for architectural model building, as well as model boats and prototype design, XPS foam is stronger than traditional EPS Thermocol and can be further strengthened with carbon fiber or wood strips. Strength to weight ratio and rigidity is perfect for RC airplanes Easy to cut with precision by the knife. Sanding can be performed on these sheets easily with a smooth finish. The thickness of the Depron sheet used is 5mm

Specifications:

- Thermal conductivity: 0.035 W/m-K
- Melting point: 70 °C
- Density: 60 kg/m<sup>3</sup>
- Firing point: 77 °C
- Water repellent: 100%

#### 2.25. Styrofoam



Fig 2.25.1: Styrofoam [1]

Styrofoam is another name for closed-cell extruded polystyrene foam (XPS), commonly called "Blue Board" manufactured as foam continuous insulation board used in walls, roofs, and foundations as thermal insulation and water barrier. This material is light blue.

Specifications:

- Thermal conductivity: 0.033 W/m-K
- Melting point: 100 °C
- Density: 50 kg/m<sup>3</sup>
- Firing point: 240 °C
- Water repellent: 100%

#### 2.26. Thermocol



Fig 2.26.1: Thermocol [1]

Thermocol is another name for Polystyrene, it's a synthetic aromatic polymer made from the monomer styrene. It can be either solid, or foam-like, and because of its resilience, it is often used in protective packaging - CD and DVD cases, and Styrofoam Peanuts.

It is most assuredly not environmentally friendly, it

doesn't degrade for hundreds of years, and is resistant to photolysis.

Specifications:

- Thermal conductivity: 0.47 W/m-K
- Melting point: 70 °C
- Density: 20 kg/m<sup>3</sup>
- Firing point: 80 °C
- Water repellent: 100%

#### 2.27. Fishing Line



Fig 2.27.1: Fishing Line [1]

A fishing line is a high strength wire. It is usually almost transparent and has a very high breaking strength. Usually, a 0.33 mm diameter fishing line can suspend a weight of 27kg without breaking. In terms of strength to weight ratio they stand on top of steel. They are mostly used in fishery and other animal bait formation. The line we used has a breaking strength of 20kg and was light green pigmented.

#### 2.28. Meteorological Balloon



Fig 2.28.1: Meteorological Balloon [1]

A balloon is something which can be inflated to a great extent, it is made up of a flexible material like rubber and the balloon we used is made up of Latex, a high strength rubber.

Specifications:

- Weight: 2Kg
- Neck Length: ≥13cm

- Neck Diameter: ≤8.3 cm
- Horizontal Length Diameter: 195-220 cm
- Diameter at burst: 1100 cm
- Inflation Diameter: ≥600 cm
- Free Lift: 2.5 kg
- Altitude Of Burst: 38000 m

#### 2.29. Helium

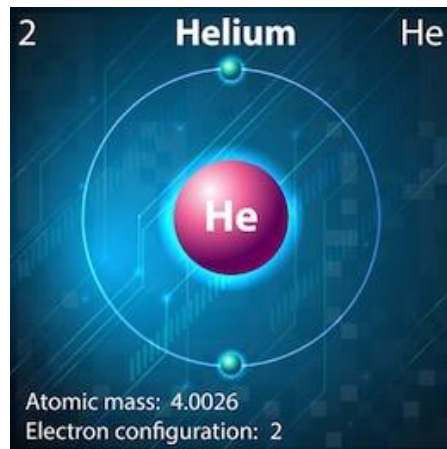

Fig 2.29.1: Helium Atom [1]

Helium is a chemical element represented symbolically as “He”, it has the atomic number 2. It's a colorless, odorless, tasteless, non-toxic, inert, monoatomic gas. It's the first noble gas in the noble gas group. Its boiling point is the lowest among all the elements. Helium is the second lightest and second most abundant element in the observable universe (hydrogen is the lightest and most abundant). It is present in about 24% of the total elemental mass, which is more than 12 times the mass of all the heavier elements combined. Its abundance is similar to this in both the Sun and in Jupiter, this is due to the very high nuclear binding energy (per nucleon) of helium-4, concerning the next three elements after helium. This helium-4 binding energy also accounts for why it is a product of both nuclear fusion and radioactive decay. Most helium in the universe is helium-4, the vast majority of which was formed during the Big Bang. Large amounts of new helium are being created by nuclear fusion of hydrogen in stars.

Its properties are:

- Atomic number (number of protons in the nucleus): 2
- Atomic symbol (on the Periodic Table of Elements): He
- Atomic weight (average mass of the atom): 4.002602
- Density: 0.0001785 g/cm<sup>3</sup>

- Material phase at room temperature: Gas
- Melting point:  $-272.2^{\circ}\text{C}$
- Boiling point:  $-268.9^{\circ}\text{C}$
- Number of isotopes (atoms of the same element with a different number of neutrons): 8; 2 stables.
- Most common isotopes: He-4 (99.999866 percent natural abundance) and He-3 (0.000134 percent natural abundance)

### 2.30. Springs



Fig 2.30.1: Springs [1]

Spring is a circular coil with an interface, its main objective is to store the sudden kinetic energy formed due to an impulse force or sudden deformation. The quality and effectiveness of spring are defined by its spring constant. All the springs are made up of elastic material, they also have a high rate of strain recovery.

### 2.31. Two-Sided / Double-Sided Stick Tape

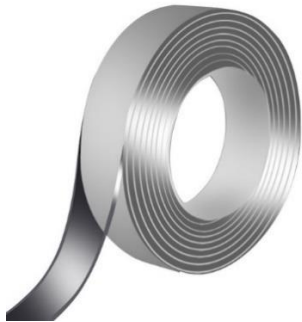

Fig 2.31.1: Two Side Sticky Tape [1]

Double-Sided stick tape is the most prominent discovery in the field of sealants. It has a high grip and is water-resistant. It's a thin film but has the grip to hold up to 200 kg of weight it's like a semi-hardened glue, it occupies the gaps in the surface roughness and forms a tight grip.

### 2.32. SD Card



Fig 2.32.1: SD Card [1]

It's the main information storage house of any electronic system, it stores all the data sensed by the sensors in the form of logic. The SD card we used has a capacity of 256Gb. It is of A1 class and has a transfer speed of 100 Mb/s.

### 2.33. Card Reader



Fig 2.33.1: Card Reader [1]

A card reader is a device for accessing the data on a memory card such as a CompactFlash (CF), Secure Digital (SD) or Multimedia Card (MMC). Most card readers also offer to write capability, and together with the card, this can function as a pen drive. The card reader is used to flash the memory card and to copy the OS to the memory card. In this Pi programming, we made use of NOOBS OS, which is a famous and most powerful OS for raspberry pi.

### 2.34. HDMI Cable



Fig 2.34.1: HDMI Cable [1]

An HDMI cable is composed of four shielded twisted pairs, with an impedance of the order of  $100 \Omega (\pm 15\%)$ , plus seven separate conductors. HDMI cables with Ethernet differ in that of the separate conductors instead form an additional shielded twisted pair (with the CEC/DDC ground as a shield).

The OS Copied to the memory card is inserted into the raspberry pi board and then it is connected to a television with the help of the HDMI cable and then the OS is installed in it.

### III. DESIGN

The O.S for raspberry pi is copied into the SD card and then the board is connected to the power source and the television. The program is made to run and the O.S is installed into the raspberry pi. Now the sensors are connected to the board one by one with the help of jumper wires, each sensor is programed and the sensed physical quantity is calibrated with the standard data and the error value is calculated, this is done for each secondary device that is fixed to the PI board. Now all the secondary devices are connected to the PI board with the help of bread-board, jumper wires, and extension cables. At a time, the entire program is made to run and the system is tested for sensing the physical quantities. The sensed reading is made to store into the memory card. Now the GPS module is fixed, installed and then analyzed to track down the system from a remote location. This constitutes the entire satellite system.

The Depron, Thermocol, and Styrofoam sheets are laminated one above the other with a 1 centimeter interlaminar gap. Then the sheets are cut in dimensions of 30cm x 30cm with an edge angle of 60 degrees. Now the upper and bottom caps are made for the box of the triangular shape of dimension 30 x 30 x 30cm and an edge angle of 60 degrees. Each of the planes was subjected to CNC carving to make sockets for wire lines, cameras, and sensors. The sensors are fixed to one of the sides and 3 image cameras and 1 IR camera are fixed to the 3 sides and the bottom sides. The pads of heating systems are fixed in between the inter-laminar gaps over the aluminum foil. And the silicon pipe is made to run throughout the body and a section of the flow is made to end over the pads. The raspberry pi was fixed in an aluminum frame and the mainboard, power system, pump are fixed rigidly to the inner surface. The connections were made so between the Sensors – Bread Board, Raspberry Pi – Breadboard, Raspberry Pi – Lithium-Ion Battery, Micro Pump – 9V Battery, Heating System – Lithium-

Ion Battery, Outlet of Micro Pump – Oxygen Tube. Raspberry Pi – Exhaust Fan of Heat Exchanger.

The planes were attached and then sanded to give a smooth curve to the edges and then the edges were sealed with the help of sealant. The edges are strengthened by rolling the fishing line to the planes and then rigidly attached by making use of superglue. To each face of the frame, a line is fixed and all these lines are made to converge at a point on the top surface. The converge line is now attached to the parachute. The setup was tested and calibrated for a few times and then after it met the accuracy and expectations the box was entirely sealed and made airtight. This constitutes the entire satellite system and satellite body.

### IV. WORKING

When the satellite system is switched on the power is supplied to the entire electronic gadgets. The sensors sense the physical quantities (parameters) and then the sensed data in the form of electronic code to the Raspberry Pi. The code is now bypassed by the board to the memory unit and the transmitter. The signal transmitted by the transmitter is received by a receiver located on the ground, the signal is demodulated and the coded data is analyzed and visualized in the system or display screen.

The coldness of the atmosphere will be opposed by the insulating casing materials and the sensors will be kept warm by the heat generated by the heating system; the entire heating system is made convection active so that there is a continuous flow of heat internally.

### V. RESULT



Fig 5.1: Atmospheric Image [1]

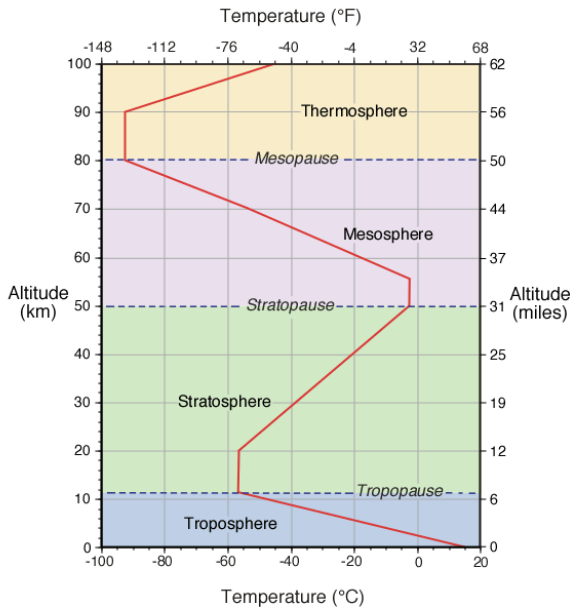

Fig 5.2: Temperature vs Altitude Graph [1]

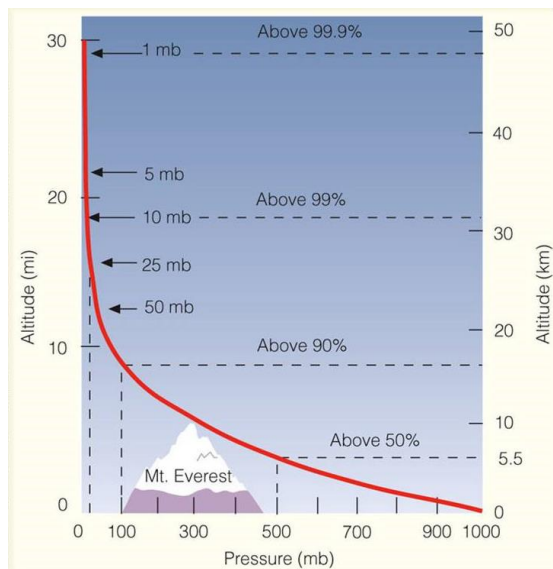

Fig 5.3: Pressure vs Altitude Graph [1]

## VI. CONCLUSIONS TO BE OBSERVED

- The troposphere extends from 0km till 11km.
- The tropopause region starts from 11km and extends to 20km.
- The stratosphere extends from 20km.
- The ozone layer starts at 14 km altitude from sea level.
- The clouds are present from 8km to 14km altitude.
- Till troposphere, the temperature decreases as we go higher in altitude.

- In the tropopause region, the temperature is constant.
- Beyond tropopause, the temperature starts to increase.
- The pressure decreases as we go higher in altitude.
- As we go higher in altitude the density of the gas decreases.
- The gases are distributed in such a way that lighter density gases are present at greater altitudes and heavy density gases are present at a lower altitude.
- In the clouds, the water molecules are spherical.
- The moisture percentage increases as the altitude increases and is present until the clouds region stop.
- The greenhouse gases are found till 10 km altitude.

## VII. REFERENCES

- [1] Images, Source - Google, "<https://www.google.com/>"
- [2] John D Anderson Jr., (6 July 2010). "Fundamentals of Aerodynamics Fifth Edition", (pg68-93)
- [3] Yunus A Cengel, Afshin J.Ghajar, (1 July 2017). "Heat and Mass Transfer: Fundamentals and Applications", (pg67-237)
- [4] Paul I. Palmer, (23 March 2017). "The Atmosphere: A Very Short Introduction", (pg1-152)
- [5] Storm Dunlop, (26 January 2017). "Weather: A Very Short Introduction", (pg1-176)
- [6] Mark Maslin, (8 July 2013). "Climate: A Very Short Introduction", (pg1-176)
- [7] James Arthur, (2 July 2019). "Raspberry Pi: The complete guide to Raspberry Pi for beginners, including projects, tips, and programming", (pg1-200)
- [8] Maneesh Rao, (30 April 2018). "Internet of Things with Raspberry Pi 3: Leverage the power of Raspberry Pi 3 and JavaScript to build exciting IoT projects", (pg386-441)
- [9] Raspberry Pi, Source - Google, "<https://www.raspberrypi.org/>"
- [10] Margit Pfundstein, Roland Gellert, Martin Spitzner, (31 January 2013). "Insulating Materials: Principles, Materials, Applications", (pg43-112)



[11] Gopi Satheesh, R. Sathikumar, N. Madhu, (25 September 2017). “Advanced Surveying: Total Station, GPS, GIS & Remote Sensing by Person”, (pg56-322)

[12] Gopi, (July 2017). “GLOBAL POSITIONING SYSTEM”, (pg1-40)

[13] John Farndon, (1 October 2002). “Buoyancy”, (pg1-32)

# IJEAST

INTERNATIONAL JOURNAL  
OF ENGINEERING APPLIED SCIENCE  
AND TECHNOLOGY

## ABOUT IJEAST

International Journal of Engineering Applied Science and Technology (IJEAST) is a peer-reviewed, open access journal that publishes high-quality research papers in the field of Engineering, Applied Science and Technology.

IJEAST aims to provide a platform for researchers, academicians, and professionals to share their innovative ideas, research findings, and practical experiences with the global scientific community.

## FOCUS AREAS

- Engineering
- Applied Science
- Technology
- Innovation & Development
- Interdisciplinary Studies



### PEER REVIEWED

All submissions are rigorously peer reviewed to ensure quality.



### OPEN ACCESS

Free and unrestricted access to research for all.



### GLOBAL REACH

Connecting researchers and professionals worldwide.



### TIMELY PUBLICATION

We ensure a swift and efficient publication process.



For more information, visit our website

[www.ijeast.com](http://www.ijeast.com)



INTERNATIONAL JOURNAL  
OF ENGINEERING APPLIED SCIENCE  
AND TECHNOLOGY

✉ [editor@ijeast.com](mailto:editor@ijeast.com)

🌐 [www.ijeast.com](http://www.ijeast.com)

📍 India



2455-2143