



# IJEAST

INTERNATIONAL JOURNAL  
OF ENGINEERING APPLIED SCIENCE  
AND TECHNOLOGY



**VOLUME : 6    ISSUE : 8    Print / Issue Publication Date: 14-Mar-2022**



**ISSN : 2455-2143**



**DOI : 10.33564/IJEAST.2021.v06i08.039**

Indexed In



[WWW.IJEAST.COM](http://WWW.IJEAST.COM)

[editor@ijeast.com](mailto:editor@ijeast.com)



# DESIGN AND DEVELOPMENT OF GROUNDNUT POD SEPARATOR MACHINE

Sachin Raut, Shubham Chaudhary, Ravi Kumar Kandasamy, Ganesh There  
Rural Energy & Infrastructure Department  
MGIRI, Wardha, Maharashtra, India

**Abstract**—Agriculture is the backbone of India. In country like India, the yield of groundnuts is very low. The serious issue in groundnut production in India is the absence of groundnut handling machines accessible or the machines which are accessible in market are expensive to farmers. Before all else, the pods of groundnut were isolated from its plants by workers. They just eliminate groundnut pods with the assistance of their hands and separate them from the plants. The yield got from this strategy, was exceptionally low since it was an extremely tedious process. It was additionally a disappointing work for the workers. The customary strategy for isolating groundnut pods from plants is by hands. That conventional strategy is anything but an adequate technique for isolating groundnut pods. To conquer this manual tedious and disappointed interaction MGIRI's REI (Rural Energy and Infrastructure Department) has created single phase electrically worked "Groundnut Pod Separating machine" The machine has the capacity of isolating 400 kg of groundnut each hour with isolating efficiencies of 90% and 95%. The machine is created from locally sourced materials, which makes it exceptionally modest and effectively reasonable and furthermore, an upkeep cost of the machine is extremely low. It comprises of two turning rotors, 1HP single phase motor and separator to remove soil and gather the groundnuts.

**Keywords**—Groundnut pods, conventional strategy, groundnut handling machines, expensive to farmers

## I. INTRODUCTION

Groundnut is a group in the legume or "bean" family. The groundnut was presumably first tamed and developed in the valleys of Paraguay. It is a perennial herbaceous plant that grows between 25 and 50 cm high. The leaves are inverse, pinnate with four flyers and two inverse combines; there is no terminal handout; every pamphlet is 1 to 8 cm long and 1 to 4 cm wide. Groundnut production in India is the second largest in the world after China. The top groundnut producing countries are displayed in table 1. Indian groundnuts are to be had in a diffusion of sorts, together with ambitious or runner, Java or Spanish, and purple Natal.

RANK	COUNTRY	PRODUCTION (Millions tones)
1	China	17
2	India	9.5
3	Nigeria	3
4	United States	1.9
	Myanmar	1.4

Fig.1 Production of Groundnuts in Different Countries

Groundnuts are one of the significant seed crops. This item is cultivated in bountiful amounts. There is a lot of time wasted within the conventional method of groundnut pod separation. The time needed for 20 Kg of groundnut case to be isolated from this manual groundnut strategy is around 1 to 1.5 hours. So we've developed advanced a brand new system for quick groundnut pod separation. The customary way of separating groundnuts is by removing them with the assistance of fingers or hitting the bundle of nuts with bars. Both the ordinary techniques cause wounds to the fingers of workers and harm to nuts, which would then be able to be utilized distinctly for oil ousting purposes. Separating groundnuts requires 12 to 15 workers for 1 acre of land. The fields should be made wet on the earlier day with a slight water system, so the hard land turns out to be free and the plants alongside the units can be pulled out effectively from the soil. When plucked, the pods should be taken from the land. Stripping the pods is a conventional practice done either by eliminating the cases physically or hitting the pack with the assistance of bar.

## II. PROBLEMS IDENTIFICATION

In the beginning, the groundnuts were isolated from their plant by the laborers. They essentially eliminate groundnut pods from the plant with the assistance of their hands. The yield obtained from this regular technique is exceptionally low, and it doesn't satisfy the demand. Furthermore, the strategy isn't affordable for farmers; it takes 12 to 15 workers, and work charges are not affordable to farmers. It is also extremely chaotic work for the laborer. The conventional way of isolating groundnut cases is by fingers or hitting the bundle of nuts with bars. Both the customary techniques cause wounds to the fingers of workers and harm to nuts. The presentation gives information that the conventional strategy is certainly not an adequate technique for isolating the groundnut. Because

of this manual interaction, recognize some serious issues, and to overcome these issues, some thoughts or ideas were created. As per produced thoughts, choosing the objective of the machine

### III. INITIAL CONCEPTS

Introducing some low cost automation in the separation of groundnuts will help overcome such a tedious, conventional process of separating. The concept of the work is,

- Observe the customary or conventional techniques to recognize the significant cycle factors.
- Calculate the critical strategy.
- Create a single prototype automation system that can control all of the processes.
- Investigate (encourage) all areas of automated farming.

### IV. CULTIVATION & HARVESTING

Groundnuts grow great in mild, sandy loam soil with a pH of 5.7–6.3. Their ability to fix nitrogen and further develop soil richness. The crop cultivation land view is displayed in the figure 1. Accordingly, they are significant in crop revolutions. Additionally, the yield of the groundnut crop itself is expanded in no time, through diminished illnesses, weeds, and pests. Sufficient degrees of calcium, magnesium, phosphorus, potassium, and miniature supplements are likewise essential for great yields. If it is too soon, such a large number of pods will be unripe. As soon as the pods are too overdue, they snap off from the stalk and stay in the soil. For harvesting, the whole plant, including a large portion of the roots, is eliminated from the soil. The fruit products have badly crumpled shells that are choked between sets of the one to four seeds for each unit. Collecting happens in two phases: In automated frameworks, a machine is utilized to remove the principle foundation of the groundnut plant by slicing through the soil just beneath the level of the groundnut pod. This permits the grounds to dry gradually to somewhat less than 33% of their unique dampness level over a time of three to four days. Generally, peanuts were pulled and reversed manually.



Fig 2. Groundnut Farm

Reaping, for the most part, entails a series of tasks such as digging, lifting, windrowing, stocking, and threshing. A portion of this cycle can be consolidated or disposed of, relying upon the system applied. Among the field activities worried about groundnut development, harvesting is the most relentless and expensive interaction. The actual technique of harvest employed relies upon the form of groundnut grown within the bunch. In some types, pod improvement is restricted to the foundation of the plant, and the stakes conveying the pods into the soil are thick and solid. Practically every one of the pods is recuperated by the plants when they are pulled out of the soil. The package kind of groundnut is commonly reaped with the aid of disposing of the pods with manual labour in India.

The variety of the work utilized to reap the groundnut crop relies upon the area. For example, male workers are utilized in Gujarat, and in Tamil Nadu, both male and female workers are utilized. Generally, one and a half acres of groundnut cropland can be harvested by 12 to 15 labourers in one day Harvesting may in some cases become an issue particularly when the yield has passed the phase of complete development and the soil has solidified. For this situation, it is standard to lift the plants by relaxing the soil either by working a plough, a hand digger, or a hand hoe along the plant lines. The exact implements that were used to select the entire crop can be used to pick the leftover pods as well, if a significant percentage of them were left within the soil after pulling the crop manually. The stakes are relatively more slender and more sensitive.

### V. COMPONENTS OF GROUNDNUT POD SEPARATING

#### 1. Table

All the components of the machine are set up on the table. The table acts as a foundation and all the load is on the table. Hence, it must be strong enough to bear all the loads. Table height is selected as per the operator's convenience, and also the safety of the operator is taken as a first priority.

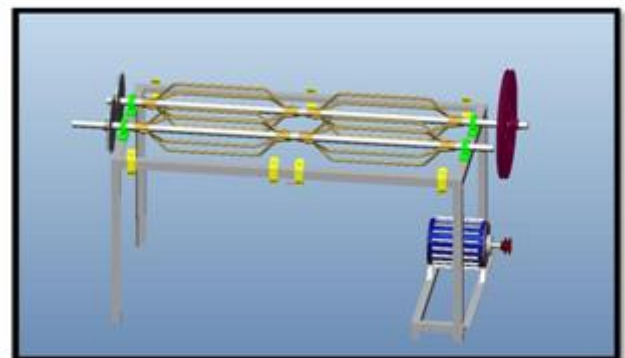

Fig.3 Table with all mountings

#### 2. Motor

An electric powered motor is an electrical device which converts electrical energy into mechanical energy. Electric motors produce linear or rotary forces meant to propel some external mechanism, along with a rotor. The rotary motion of the rotor helps to separate groundnut pods from the plant. An electric motor is generally designed for continuous rotation over a significant distance compared to its size. A single phase 1 hp motor is used to transmit power from motor to pulley to rotate the rotor. The base frame of the motor is mounted on the table which is shown in fig 2 & 3.



Fig.3 Transmitted power from motor to pulley

### 3. Rotor/Cutter

It is the active or rotating portion of the machine. It consists of flanges which are made up of iron bars, which help to separate the pod from the plant. Two rotors are mounted on top of the table so that the two operators can perform their work. When the bunch of groundnut plants are fed to the rotor, it creates a shearing action and the pods get separated from the plant. As shown in fig. 4 four rotors are mounted on the shaft which rotates in opposite directions to each other.



Fig.4 Fabricated view of rotor

### 4. Separator

Separator is the displacement motion component which is used to collect the groundnuts and helps to remove soil stick to the pod of groundnuts. Separator is connected to eccentric mechanism and due to revolutionary stroke of eccentric it created up and down motion which is further helps to collect groundnuts.



Fig.5 Fabricated view of separator

The bottom part of the separator are made up of steel mesh which is use to remove the soil on pod and clean pods are collected at a point.

### VI. WORKING PRINCIPLE

A single phase 1 HP electric motor is used to drive two rotor shafts through a belt pulley drive. The two rotating shafts mounted on bearings will get turned because of the belt pulley course of action. The whole assembly of bearings, shaft, rotor and separator are mounted on rigid support. L- Angles are welded around the periphery of rotors. The L-angles are so welded that they will not contribute to dynamic unbalancing. Henceforth, by considering dynamic adjusting rules, all L angles are welded. When the groundnuts in the plant are held against the side of the safety cover, which is projected outside the turning rotors, striking activity happens.



Fig.6 Fabricated view of the Machine



This produces a hit on the groundnuts. This strike is adequate to isolate groundnuts from their plants. The plant stays in hand and isolated groundnuts are discarded by striking activity. Isolated groundnuts tumble down on the slant of the sheet and move down into the separator. The separator, which vibrates because of eccentric it, eliminates all the soil on the pods and clean groundnuts are gathered. A maximum of four operators can work on this machine. As a result, machines are designed and built in this manner to reduce human effort.

**VII. DESIGN AND CALCULATIONS**

**1. Groundnut Specification**

A single groundnut plant contain 15-30 groundnuts (on an average)

- Length of groundnut = 650 mm
- Width of groundnut = 12 mm
- Thickness of groundnut = 11 mm

**2. Specification of Rotor**

- Length of rotor = 650 mm
- Width of rotor = 190.50 mm
- Thickness of blade = 12 mm

**3. Calculation of Torque required**

To separate the pod from the plant 23 N Tensile force is required

Here we use up to 10 to 15 groundnut plant so the max force is Required to remove the groundnut pod is up to 300 N

Torque = Force \* perpendicular distance  
 $T = 300 * 117$

**T = 35.4 N.m**

**Power required**

$$\text{Power} = \frac{2 \pi N T}{60}$$

$$P = \frac{2 \pi * 180 * 35.4}{60}$$

**P = 667.27 watt**

So power required for machine is 1 hp

**Design of Shaft (shaft subjected to twisting moment only)**

To calculate the dia. of shaft required

$$\frac{T}{J} = \frac{\tau}{r}$$

T = Twisting moment or torque acting upon the shaft

$\tau$  = Torsional shear stress

J = Polar moment of inertia of shaft

r = Dist. From neutral axis to the outer most fiber (d/2)

$$\tau = r * \frac{T}{J}$$

$$T = \frac{\pi}{16} * \tau * d^3 \dots (\text{Twisting moment or torque acting on shaft})$$

$$\tau = \frac{16 * T}{\pi * d^3}$$

$$\tau = \frac{16 * T}{\pi * d^3}$$

$$r * \frac{T}{J} = \frac{16 * T}{\pi * d^3}$$

$$r * \frac{35.4 * 10^3}{\frac{\pi}{32} * d^4} = \frac{16 * 35.4 * 10^3}{\pi * d^3}$$

**D = 21 mm**

**Selection of belt / Belt tension on pulley**

To calculate required specification of belt to transmit power from motor to rotor shaft

PR (Rated power) = 0.66 KW

Design Power = PR \* K1 ... (K1 = 1.10 for line shaft TXV-2)

$$P_d = 0.66 * 1.10$$

$$P_d = 0.72 \text{ KW}$$

Selecting the section of belt on the basis of design power i.e 0.72 KW

From table XV-8

For suggested range of power 0.35 – 3.5 KW

Nominal Width (w) = 13 mm

Nominal Thickness (t) = 8 mm

Tension Factor (kc) = 2.52

Minimum dia. of pulley = 50.8 mm



**Peripheral velocity :**

$$V_p = \frac{\pi D_1 N_1}{60}$$

$$V_p = \frac{\pi * 50.8 * 1440}{60 * 1000}$$

N1 = 1440 rpm of motor

$$V_p = 3.8 \text{ m/sec}$$

**Dia. Of bigger pulley**

$$D_1 * N_1 = D_2 * N_2$$

$$50.8 * 1440 = D_2 * 180 \dots\dots\dots(N_2 = \text{rpm of rotor})$$

$$\boxed{D_2 = 406 \text{ mm}}$$

\dots\dots\dots(406mm  $\approx$  16")

**Ratio of tension**

Angle of lap on smaller pulley

$$\theta = \pi - \frac{D_2 - D_1}{C}$$

$$C = D_1 + D_2 \dots\dots\dots(XV-10)$$

$$\theta = \pi - \frac{406.4 - 50.8}{406.4 + 50.8}$$

$$\theta = 0.77$$

$$\frac{F_1}{F_2} = e^{\frac{u\theta}{\sin \frac{\alpha}{2}}}$$

u = 0.3 \dots\dots\dots(coefficient of friction TXV-10)

$$\alpha = 40$$

$$\frac{F_1}{F_2} = e^{\frac{0.3 * 0.77}{\sin \frac{40}{2}}}$$

$$\frac{F_1}{F_2} = 1.96 \dots\dots\dots 1$$

Also,

$$F_1 - F_2 = \frac{P_d}{V_p}$$

$$F_1 - F_2 = \frac{0.72 * 10^3}{3.8}$$

$$F_1 - F_2 = 189.47 \text{ N} \dots\dots\dots 2$$

From equation 1&2

$$F_1 - F_2 = 189.74$$

$$1.96 F_2 - F_2 = 189.47$$

$$F_2 = 197.36$$

**Power capacity per belt**

$$F_w - F_c * \frac{e^{\frac{u\theta}{\sin \frac{\alpha}{2}}} - 1}{e^{\frac{u\theta}{\sin \frac{\alpha}{2}}}} * V_p \dots\dots\dots 3$$

$$F_w = w * w \dots\dots\dots(TXV-8)$$

$$F_w = 169 \text{ N}$$

$$F_c = K_c * \frac{V_p}{5}$$

$$= 2.52 * \left[ \frac{3.8}{5} \right]^2$$

$$F_c = 1.4 \text{ N}$$

Put in equation 3

$$169 - 1.4 * \frac{1.96 - 1}{1.96} * 3.8$$

$$\text{Power capacity/ belt} = 166.39 \text{ watt}$$

**Length of belt**

$$L = \pi (r_1 + r_2) + 2c \frac{(r_1 - r_2)^2}{c}$$

$$L = 1701.71 \text{ mm}$$

**Tension in belt**

To calculate actual tension in belt Torque is calculated as per the motor selected

$$\text{Power} = 1 \text{ Hp}$$

$$745.7 = \frac{2 \pi N T}{60}$$

$$745.7 = \frac{2 \pi * 180 * T}{60}$$

$$\text{Torque} = 39.56 \text{ N.m}$$



T1&T2 = tension in the tight and slack side of the belt resp. in N

$$\text{Torque transmitted} = (T1-T2)*R$$

$$39.56 * 10^3 = (T1-T2)*203$$

$$(T1-T2) = \frac{39.56*10^3}{203}$$

$$(T1-T2) = 194.87 \text{ N}$$

We know that,

$$2.3 \log \frac{T1}{T2} = u * \theta$$

u = coefficient of friction 0.3

$$2.3 \log \frac{T1}{T2} = 0.9424$$

$$\log \frac{T1}{T2} = 0.4098 \dots \dots \dots \text{Taking antilog}$$

$$\frac{T1}{T2} = 2.57$$

$$T1 = 2.57 T2$$

$$2.57 T2 - T2 = 197.87 \text{ N}$$

$$\boxed{T2 = 49.03 \text{ N}}$$

Total load acting on pulley

$$Wt = T1+T2+W$$

$$W \text{ (weight of pulley)} = 53.95 \text{ N}$$

$$Wt = 126.03 + 49.03 + 53.95$$

$$\boxed{Wt = 229.01 \text{ N}}$$

**Shaft subjected to Fluctuated loading**

Shaft carrying an overhanging load of pulley and gear having a distance of 0.114 m apart from bearing and also carrying an udl of 78.48 N

FBD is as shown in fig.

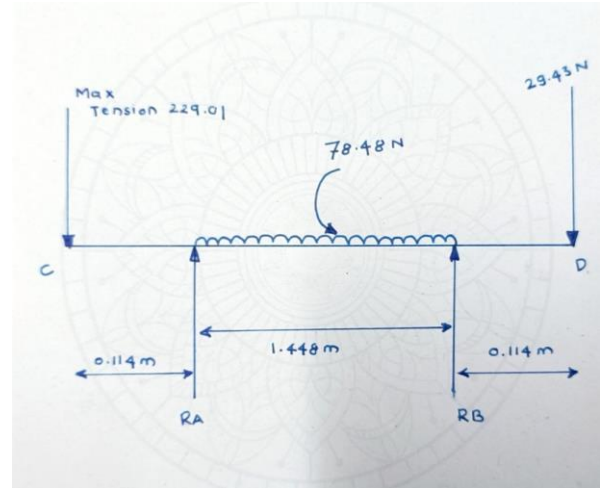

Fig.7 Free body diagram

Sum of all upward forces = Sum of all downward forces

$$Ra + Rb = 229.01+109.87+29.43$$

$$Ra = 368.31- Rb \dots \dots \dots \text{eqn 1}$$

Taking  $\sum m$  at pt D

$$-29.43*1.6 - Rb*1.56 - 109.87*0.83 + Ra*0.114$$

$$\boxed{Rb = 66.67 \text{ Nm}}$$

Put in eqn 1

$$\boxed{Ra = 301.74 \text{ Nm}}$$

To calculate actual bending moment

Bending moment at C and D is 0

Bending moment at B

$$-29.43*0.114 = -3.35 \text{ Nm}$$

Bending Moment at A

$$-29.43*1.56+66.57*1.448-109.87*0.724 = -29.32 \text{ Nm}$$

We see that bending moment at A is maximum =  $29.32 * 10^3$

Equivalent twisting moment

$$Te = \sqrt{(Km * M)^2 + (Kt * T)^2}$$



$$T_e = \sqrt{(2 * 29.32 * 10^3)^2 + (1.5 * 39.56 * 10^3)^2}$$

$$T_e = 84.42 \text{ Nmm}$$

$$T = \frac{\pi}{16} \tau * D^3$$

$$84.42 * 10^3 = \frac{\pi}{16} \tau * D^3$$

$$\tau = r * \frac{T}{J}$$

$$D = 23 \approx 25 \text{ mm}$$

Select max diameter of shaft i.e 25 mm

### VIII. PERFORMANCE ANALYSIS

#### 1. Work by Machine

Based on the working of the groundnut pod separator the following performance analyses were made. According to the analysis-

Number of labor required = 2

Cost of labor = Rs. 250/- each

Collection of groundnuts per hour = About 400 kg by 2 labour on machine

Operating Time: Machine operates on single phase motor so anytime one can use machine

#### 2. Work by manual process

Number of labor required = 12 to 15

Cost of labor = Rs.250 each = 15\*250= 3750 Rs for 1 acre

Collection of groundnuts per hour = approximately 80 - 90 kg

Working time: as per availability of labour

### IX. CONCLUSION

The portable groundnut separator will assist with improving isolating productivity in large scale. It like wise assists with decreasing human efforts. The groundnut separator is useful for farmers in separating groundnut pods in the most cost-effective and time-efficient manner of a large number of laborers will be disposed of as just two operators can do the total separating and collecting activity. This machine is electrically operated and it is able to be without delay transported to the groundnut farms. The weight of the machine is low and it is convenient to

operate and simple to move anyplace. Additionally its expense is low and reasonable for the farmers.

### X. REFERENCES

- [1] Rajasekar. M, Arunkumar. S, Design fabrication and performance analysis of groundnut thresher, International Research Journal of Engineering and Technology, 04 (02), 2017, 2395-0056.
- [2] Ashok. S. Andhale, Sayed Wajahat, Design and development of groundnut pod separating machine, International Journal of Latest Engineering and Management Research, 02 (04), 2017,455-4847.
- [3] Deshmukh Shubham, Giramkar Harsha wardhan, Design and fabrication of groundnut pod separating machine, International Journal of Recent Research in Civil and Mechanical Engineering, 02 (02),147-150.
- [4] Ghatage J. S., Bandagar, Development and performance evaluation of pedal operated ground nut podstripping machine, International Journal of Agricultural Engineering, 07 (01), 2014,217-220.
- [5] Ikechukwu Celestine Ugwuoke. Olawale James Okegbile, Design and Fabrication of Groundnut Shelling and Separating Machine, International Journal of Engineering Science Invention, 03 (04), 2014, 2319-6734
- [6] Sunil K. Mathanker a , Tony E. Grift a, Alan C. Hansen a,b , Effect of blade oblique angle and cutting speed on cutting energy for energycane stems, biosystems engineering 133 (2015) 64 e70
- [7] Ali Mirzazadeh, Shamsollah Abdollahpour and Asghar Mahmoudi, Ali Ramazani Bukat Intelligent modeling of material separation in combine harvester's thresher by ANN, International Journal of Agricultureand Crop Sciences. ISSN 2227-670X ©2012 IJACS Journal
- [8] Ashish S. Raghtate and Dr. C.C. Handa, "Design and Fabrication of Groundnut Sheller Machine", IJIRST, Volume1, Issue 7, ISSN (online): 2349-6010, December 2014
- [9] Gol, A. K. and S. K. Nada: Performance of power operated groundnut stripper. AMA, 22(3):25-28.
- [10] Kaul, R. N. and C. O. Egbo: Introduction to Agricultural Mechanization. First edition. Macmillan Education Ltd. London

# IJEAST

INTERNATIONAL JOURNAL  
OF ENGINEERING APPLIED SCIENCE  
AND TECHNOLOGY

## ABOUT IJEAST

International Journal of Engineering Applied Science and Technology (IJEAST) is a peer-reviewed, open access journal that publishes high-quality research papers in the field of Engineering, Applied Science and Technology.

IJEAST aims to provide a platform for researchers, academicians, and professionals to share their innovative ideas, research findings, and practical experiences with the global scientific community.

## FOCUS AREAS

- Engineering
- Applied Science
- Technology
- Innovation & Development
- Interdisciplinary Studies



### PEER REVIEWED

All submissions are rigorously peer reviewed to ensure quality.



### OPEN ACCESS

Free and unrestricted access to research for all.



### GLOBAL REACH

Connecting researchers and professionals worldwide.



### TIMELY PUBLICATION

We ensure a swift and efficient publication process.



For more information, visit our website  
[www.ijeast.com](http://www.ijeast.com)



INTERNATIONAL JOURNAL  
OF ENGINEERING APPLIED SCIENCE  
AND TECHNOLOGY

✉ [editor@ijeast.com](mailto:editor@ijeast.com)

🌐 [www.ijeast.com](http://www.ijeast.com)

📍 India



2455-2143