



IJEAST

INTERNATIONAL JOURNAL
OF ENGINEERING APPLIED SCIENCE
AND TECHNOLOGY



VOLUME : 8 ISSUE : 12 Print / Issue Publication Date: 03-Jul-2024



ISSN : 2455-2143



Indexed In



WWW.IJEAST.COM

editor@ijeast.com

HUMAN HEART SIMULATION WITH ARRHYTHMIA USING ELECTRONICS

Ajeeth R
Biomedical Engineer, Chennai,
Tamil Nadu, India

Abstract— ECG interpretation is a lifesaving skill. To interpret the ECG, one must understand the physiology and science behind it. My aim is to develop a handheld device that will help paramedics, undergraduate residents, school/college students, or anyone interested in ECG interpretation to learn about the mechanism of action. I hope this device will create interest for students to learn and will help interpret ECG. I used simple electronics like LEDs and servo motors to visualize the human heart. By selecting a rhythm in the selector switch, the rhythm selection will be displayed in the LCD and LEDs will glow according to the rhythm selected, created a few algorithms for the visualization of basic arrhythmia.

Keywords— ECG, ECG interpretation, Emergency, ECG learning with electronics, Simulation, Arduino.

I. INTRODUCTION

The electrical tracing of the heart is recorded invasively from the body's surface is called **Electrocardiogram (ECG/EKG)**. William Einthoven was named “Father of Electrocardiography” and won the Nobel Prize in 1924. Soon ECG became a clinical diagnostic tool and was used globally in almost every healthcare setting. Developing skills and knowledge in ECG interpretation is important as cardiovascular death is the number one cause of death. Many healthcare providers find advanced interpretation of ECG a complex task. Error in the analysis may lead to misdiagnosis, delaying the appropriate treatment ^[1] (Yasar Sattar, lovely chhabra, 2023).

A. Anatomy and physiology:

To understand the ECG we must understand cardiac anatomy and coronary distribution. The heart is a muscular organ with 4 chambers (Right and left atria, right and left ventricles) and 4 valves (Tricuspid, Mitral, Aortic, and Pulmonic valves). The heart has three main circulations.

1. **Pulmonary circuit:** The Pulmonary circuit converts the deoxygenated blood to oxygenated blood. The Pulmonary circuit starts from the Right Atrium. The Superior and inferior vena cava which carries the deoxygenated blood empties into the right atrium. Then

blood transits to the Right ventricle via the Tricuspid valve. The Right ventricle pumps the deoxygenated blood into the lungs via the pulmonary artery through the pulmonic valve. The deoxygenated blood gets purified by the lungs ^[2].

2. **Systemic circuit:** The oxygenated blood from the lungs empties into the left atrium via 4 pulmonary veins. The blood transits to the left ventricle via the Mitral valve. The left ventricle pumps the blood to the whole body via the Aorta through the aortic valve. The blood reaches every organ and each part of the body through **microcirculation.Artery -> Arterioles -> Capillaries -> Venules -> Veins**. The veins again collect deoxygenated blood and empty into the right atrium and the cycle continues ^[2].

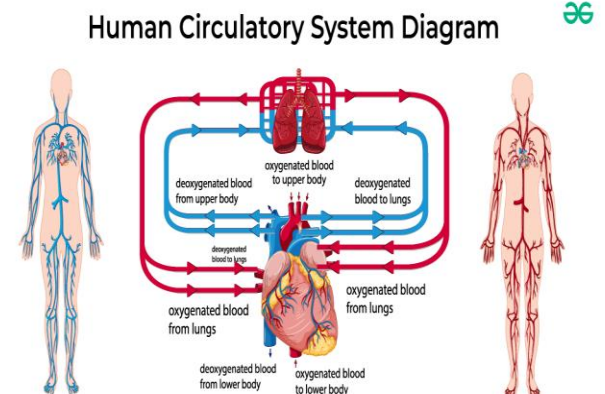

Fig.1. Human Circulatory system.

(Courtesy: <https://media.geeksforgeeks.org/wp-content/uploads/20231019112627/Human-Circulatory-System-Diagram.png>)

3. **Coronary circuit:** The Heart is a muscle that needs oxygenated blood to function. It has its own supply of blood through coronary arteries and veins. These arteries rise from the aortic sinuses, superior to the aortic valve. The left posterior aortic sinus and anterior sinus give rise to the left and right coronary arteries respectively. The **Left coronary artery** distributes to the left side of the heart. The Left coronary divides into the **Left anterior descending artery** and **circumflex**

artery. The **Right Coronary artery** distributes blood to the right atrium, part of both ventricles and the heart's conduction system. It divides into the **marginal artery** and the **Posterior descending artery** which runs through the posterior portion towards the apex of the heart. The deoxygenated blood empties into the coronary sinus via the **Great cardiac vein, middle cardiac vein, small cardiac vein, and anterior cardiac veins** [2].

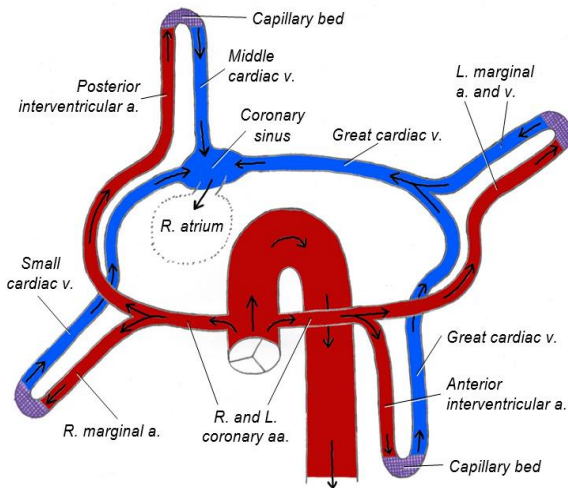

Fig.2. Coronary Circulation System.

(Courtesy:[https://bio.libretexts.org/Courses/West_Hills_College_-_Lemoore/Human_Anatomy_Laboratory_Manual_%28Hartline%29/17%3A_Cardiovascular_System__The_Heart/17.07%3A_Coronary_Circulation](https://bio.libretexts.org/Courses/West_Hills_College/_Lemoore/Human_Anatomy_Laboratory_Manual_%28Hartline%29/17%3A_Cardiovascular_System__The_Heart/17.07%3A_Coronary_Circulation))

The Heart is a mechanical pump whose activity is governed by an electrical conduction system. The heart has two types of cells. **Pacemaker cells and non-pacemaker cells.** The pacemaker cells are located in the SA node, and AV node to drive the rate and rhythm of the heart. The special function of the pacemaker cells is spontaneous depolarization with no true resting potential. When the spontaneous depolarization reaches a threshold voltage, it triggers a depolarization followed by repolarization. The non-pacemaker cells mainly comprise the atrial and ventricular cardiac muscle cells and Purkinje fibers of the conduction system. They consist of true resting membrane potential, and upon initiation of an action potential, rapid depolarization is triggered, followed by a plateau phase and subsequent repolarization. Action potentials are generated by ion conductance via the opening and closing of the ion channels. The heart muscles are striated and organized into sarcomeres. Extensive branching of the cardiac muscle fibers and their end-to-end connection with each other through intercalated discs make them contract in a wave-like fashion [1] (Yasar Sattar, lovely

chhabra, 2023).

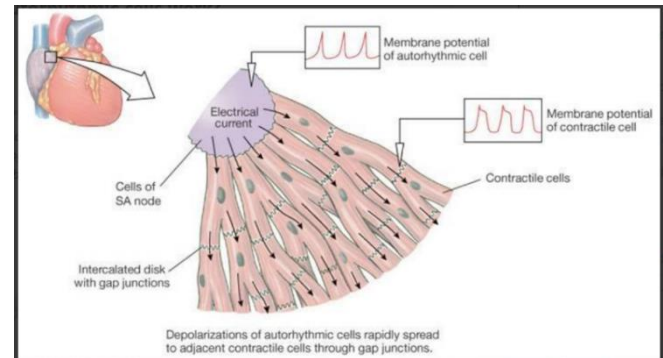

Fig.3. Coronary Myocyte.

(Courtesy:<https://qph.cf2.quoracdn.net/main-qimg-9515597406fae91b483e44a290e02f4b.webp>)

Conduction System: The conduction system is a collection of nodes and cells that initiate and coordinate the contraction of the heart muscle. The **Sino Atrial node** collection of pacemaker cells, located in the upper wall of the right atrium. These pacemaker cells spontaneously generate electrical impulses. The impulse travels via gap junctions and results in atrial contraction. The **Bachmann's bundle** transmits the impulse to the Left atrium. The impulses then converge at the **atrioventricular node**, located within the atrioventricular septum. The impulse from the SA node reaches the AV node via three internodal pathways. The impulse delays about 120 seconds to ensure that the atria have enough time to eject blood to the ventricles. Following the AV node, the impulse passes to the **AtrioVentricular Bundle / Bundle of His**. It descends intraventricular septum and divides into two bundles. **Right Bundle Branch** which supplies to right ventricular Purkinje fibers and **Left Bundle Branch** which supplies to left ventricular Purkinje fibers. The **purkinje fibers** collection of sub endocardial plexus and conduction cells, located in the sub endocardial surface of ventricular walls. They rapidly transmit impulses from the AV Bundle to the myocardium of ventricles. This allows coordinated contraction of ventricular muscle [3] (Sophie White, 2023). The conduction pathway impulses are conducted through a specialized pathway so that if one pacemaker fails, the next part of the conduction pathway can initiate the impulses to fill the gap [4] (Philip Woodrow, 2010).

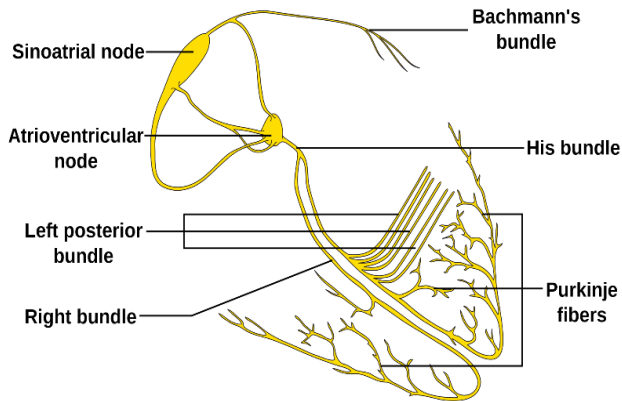

Fig.4. Conduction system of the heart.

(Courtesy:<https://upload.wikimedia.org/wikipedia/commons/thumb/a/ae/ConductionssystemoftheheartwithouttheHeart-en.svg/1920px-ConductionssystemoftheheartwithouttheHeart-en.svg.png>)

B. Introduction to Electrocardiogram:

The ECG is simply recording of the heart's voltage vs. time. By placing electrodes on the skin, we can record the electrical activity of the heart ^[1] (Yasar Sattar, lovely chhabra, 2023). Figure 5 shows the Einthoven triangle for limb leads. Lead I measures electrical activity from the right arm to the left arm. Lead II measures electrical activity from the right arm to the left foot and finally, Lead III measures the electrical activity from the left arm to the left foot.

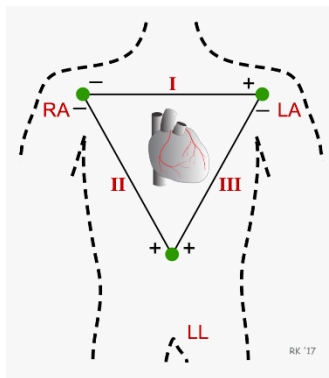

Fig.5. Einthoven Triangle for limb leads

(Courtesy:https://www.pngitem.com/middle/iihJohx_ecg-einthoven-triangle-limb-leads-hd-png-download)

Typically Lead II ECG is used for analysis. Figure 6 shows a typical ECG wave with labeling.

P-Wave: Represents the atrial repolarization, and is relatively broad and shallow. Normal P wave timing is 0.08 seconds. Atrial depolarization is initiated by the SA node, located in the Right atrium, the right atrium gets depolarized followed by the left atrium. As the P wave ends, the atria are completely depolarized ^[5] (Anthony Dupre MS, et al).

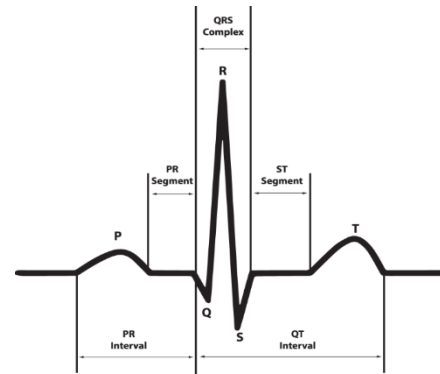

Fig.6. ECG waveform with labeling.

(Courtesy:https://media.springernature.com/lw685/springer-static/image/art%3A10.1038%2Fs41597-020-0386-x/MediaObjects/41597_2020_386_Fig1_HTML.png)

PR Interval: It represents the time from the beginning of atrial depolarization to the start of ventricular depolarization and includes a delay at the AV node normally 1.2 - 2.0 seconds. It's the measure of time for an impulse to travel from atrial excitation and through the atria and atrioventricular node ^[5] (Anthony Dupre MS, et al). Variation in the PR interval leads to various disorders ^[1] (Yasar Sattar, lovely chhabra, 2023).

QRS complex: After the AV node, the right and left ventricles begin to depolarize, representing the ventricular contraction which is around 0.08 - 0.10 seconds ^[5] (Anthony Dupre MS, et al). The first negative wave is called **q-wave** and represents the depolarization of the interventricular septum. **R wave** is the tallest wave in ECG wave, representing the passing of electrical impulse down the ventricle. **S-wave** represents the final depolarization of purkinje fibers. QRS complex is the tallest part of complexes, which comprises bundle of his, bundle branches and purkinje fibers ^[1] (Yasar Sattar, lovely chhabra, 2023).

T-wave: The ventricles repolarize after contraction giving rise to T-waves ^[5] (Anthony Dupre MS, et al). T-wave morphology is highly susceptible to cardiac and non-cardiac influences ^[1] (Yasar Sattar, lovely chhabra, 2023).

ST- Segment: It's the period when the ventricles are completely depolarized and contracting starting from the s-wave to the beginning of the T-wave ^[5] (Anthony Dupre MS, et al). Average duration 0.8 to 1.2 seconds. ST segment is the isoelectric line that lies in the same line as the PR interval. Elevation or depression of the ST segment denotes myocardial injury or ischemia ^[1] (Yasar Sattar, lovely chhabra, 2023).

QT- Interval: It's the time segment from when the ventricle begins their depolarization to the time when ventricles are repolarized to their resting potentials ^[5] (Anthony Dupre

MS, et al). The normal QT interval is 0.4 to 0.44 seconds. Prolonged QT interval may lead to lethal arrhythmia.

C. Common Arrhythmia:

Normal Sinus Rhythm: It is the heart's default rhythm.

Pacemaker cells in the SA node initiate the impulse at a rate of 60 to 100 BPM^[6] (Ed Burns and Robert Buttner, 2011). If the rate is greater than 100, termed as Sinus tachycardia. Typical Sinus rhythm is shown in Figure 7.1.

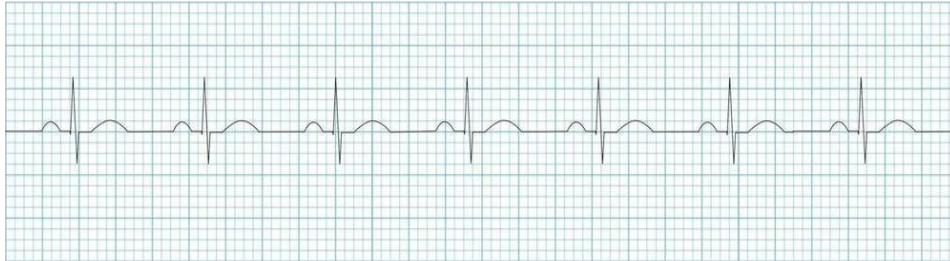

Fig.7.1. Normal Sinus Rhythm.

(Courtesy: <https://litfl.com/wp-content/uploads/2018/08/ECG-Normal-sinus-rhythm-strip.jpg>)

Junctional Rhythm: Junctional rhythm occurs when the impulse starts at the AV node instead of the SA node. Sometimes the SA node may fire a bit late, AV node takes over and initiates the impulse. Occurs when there is increased automaticity in the AV node coupled with

decreased automaticity in the SA node. Junctional rhythm can occur in 3 types. A. Absent P-waves, B. Inverted P-waves, C. Retrograde P-waves. P-wave absence Junctional rhythm is shown in figure 7.2.

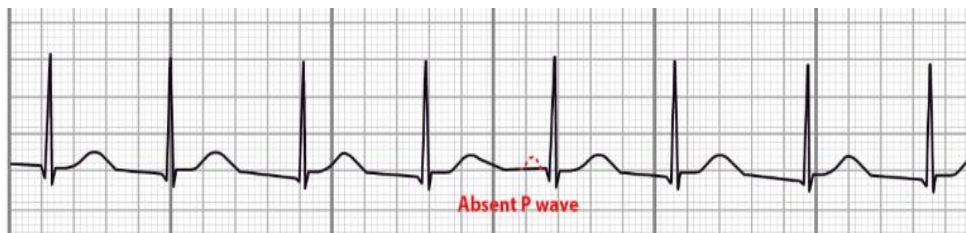

Fig.7.2 Junctional Rhythm.

(Courtesy: <https://cdn.shopify.com/s/files/1/2630/9452/files/junctional-rhythm-3-accelerated.jpg?v=1615514511>)

Ventricular Rhythm: When the SA node is blocked, latent pacemaker cells become active and start conducting. When the ventricle takes over it results in Ventricular Rhythm^[8]

(Mahesh Kumar, et al, 2023). There will be no P-waves and qRS will be wide as shown in figure 7.3.



Fig.7.3 Ventricular Rhythm.

(Courtesy: <https://litfl.com/wpcontent/uploads/2018/08/Accelerated-Idioventricular-Rhythm-AIVR-ECG-5.jpg>)

Ventricular Tachycardia: V-Tach refers to a wide qRS complex greater than 120 milliseconds. This can be

thermodynamically unstable and life-threatening^[9] (Steven Lome).

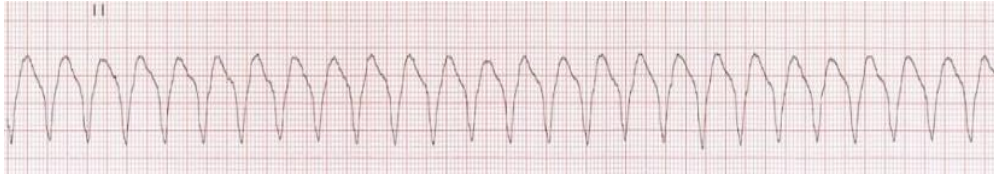

Fig.7.4 Ventricular Tachycardia.

(Courtesy:<https://litfl.com/wp-content/uploads/2018/08/Monomorphic-ventricular-tachycardia-VT-3-1024x513.jpg>)

First Degree AV Block: There is a delay in conduction from the atria to the ventricles. The rest of the conduction system remains undisturbed. The PR interval is greater than 200

milliseconds ^[10] (John Larkin and Robert Buttner, 2021). This condition is always asymptomatic and found only in regular ECG checkups.



Fig.7.5 First Degree AV Block.

(Courtesy:<https://litfl.com/wp-content/uploads/2018/08/ECG-Rhythm-strip-PR-interval-prolonged-1st-degree-AV-block.jpg>)

Second Degree AV Block Type I: Commonly called Wenckebach / Mobitz1. Progressive prolongation of the PR interval culminating in a non-conducting P wave. It is due to

a reversible block at the AV node. Malfunctioning AV node cells tend to progressively fatigue until they fail to conduct an impulse ^[11] (Ed Burns and Robert Buttner, 2024).

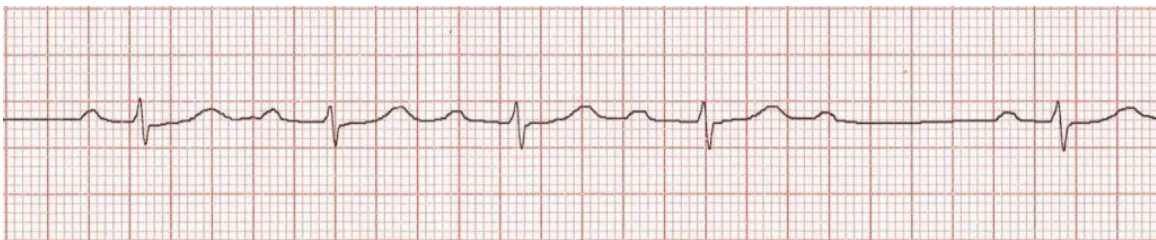

Fig.7.6. Second Degree AV Block – Type I.

(Courtesy:<https://litfl.com/wp-content/uploads/2018/08/ECG-Wenckebach-Phenomenon-1024x188.jpg>)

Second Degree AV Block Type II: There are intermittent non-conducted P-waves with constant PR interval. It is due to failure of conduction at the level of His bundle type II is more likely due to structural damage to the heart. Mobitz II

is an “all or none” phenomenon where His-Purkinje cells suddenly fail to conduct the impulse ^[12] (Ed Burns and Robert Buttner, 2024).

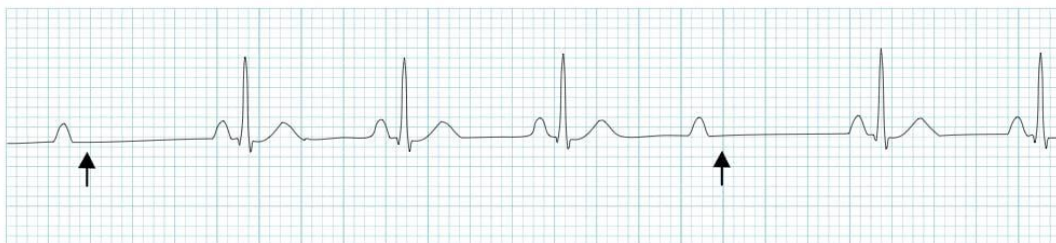

Fig.7.6. Second Degree AV Block – Type II.

(Courtesy:<https://litfl.com/wp-content/uploads/2018/08/ECG-Mobitz-II-Hay-AV-Block-1.jpg>)

Third Degree AV Block/Complete Heart Block: There is a complete absence of AV conduction. It may be due to profound fatigue of AV Nodal cells and/or complete conduction failure of his-purkinje system ^[13] (John Larkin

and Robert Buttner, 2021). PR interval changes as in Mobitz 1. Here the P wave can be seen merging with qRS complexes.

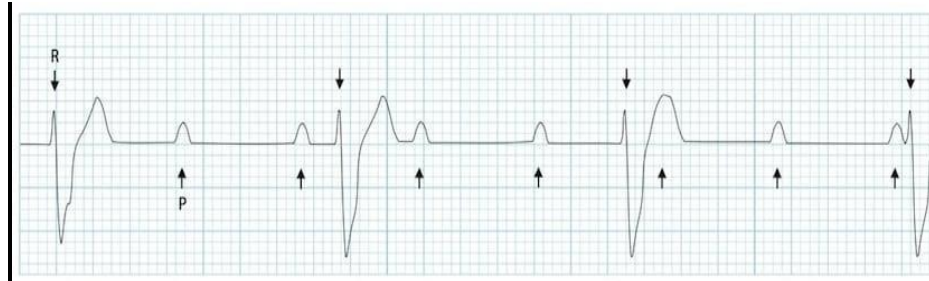

Fig.7.7. Complete Heart Block

(Courtesy:<https://litfl.com/wp-content/uploads/2018/08/3rd-degree-heart-block.jpg>)

Pulseless Electrical Activity: It occurs when organized electrical activity of the heart persists but the ejection of the

left ventricle is not sufficient enough to produce a detectable pulse ^[14] (Chris Nickson, 2020).



Fig.7.8 Pulseless Electrical Activity.

(Courtesy:<https://www.registerednursen.com/wp-content/uploads/2022/10/pulseless-electrical-activity-pea-quiz.jpg>)

Pulseless Ventricular Tachycardia is a life-threatening cardiac arrhythmia where ventricular contractions are very rapid and ineffective contractions. Due to rapid contractions, Cardiac output decreases and pulse is absent. Abnormal

ventricular contraction and asynchrony even reduce the effectiveness of contraction and alter the hemodynamics ^[15] (Adam Foglesong and Dana Mathew, 2023).

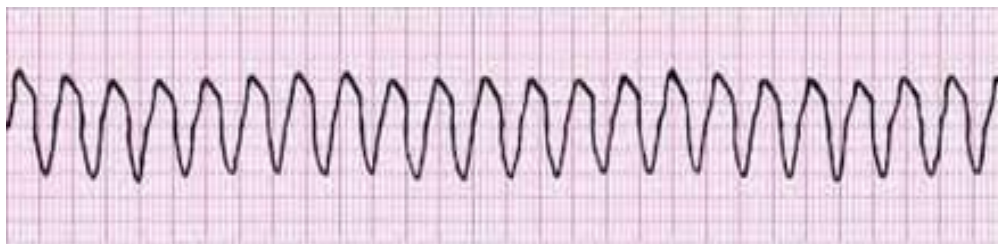

Fig.7.9 Pulseless Ventricular Tachycardia.

(Courtesy:<https://acls.com/wpcontent/uploads/2023/09/ventricular-tachycardia-1.jpg>)

II. MATERIALS AND METHODS

ECG is the most vital diagnostic tool in diagnosing cardiac abnormalities. Analyzing ECG is a skill that develops by constant practice. There must be no space for error in

analyzing the rhythm.

A. Proposed Model:

The device is designed to learn about cardiac arrhythmia. The microcontroller used is **Arduino UNO**. Arduino UNO

is a microcontroller based on **ATmega328p**. It has 14 digital input/output pins (of which 6 can be used as PWM outputs), 6 analog inputs, a 16 MHz ceramic resonator (CSTCE16M0V53-R0), a USB connection, a power jack, an ICSP header and a reset button. It contains everything needed to support the microcontroller. It can be simply connected to a computer with a USB cable or powered with an AC-to-DC adapter or battery to get started. Arduino

programs are written in the Arduino Integrated Development Environment (IDE). **Arduino IDE** is a special software running on the system that allows the user to write sketches (synonym for program in Arduino language) for different Arduino boards. After the sketch is written in the Arduino IDE, it should be uploaded on the Arduino board for execution^[6] (Leo Louis, 2016).

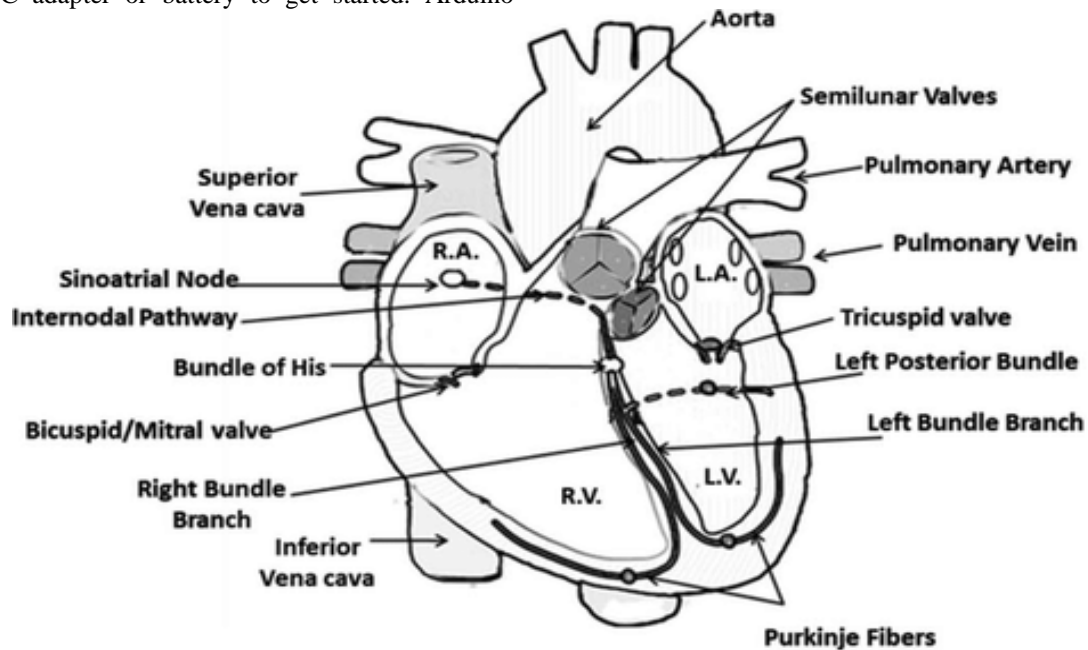

Fig.8 Internal anatomy of the heart with the impulse conduction pathway.

(Courtesy: [https://www.researchgate.net/profile/Robert-](https://www.researchgate.net/profile/Robert-Harbaugh/publication/270603738/figure/fig5/AS:614301840707618@1523472380809/a-a-diagram-of-the-internal-anatomy-of-the-heart-with-the-impulse-conduction-pathway.png)

[Harbaugh/publication/270603738/figure/fig5/AS:614301840707618@1523472380809/a-a-diagram-of-the-internal-anatomy-of-the-heart-with-the-impulse-conduction-pathway.png](https://www.researchgate.net/profile/Robert-Harbaugh/publication/270603738/figure/fig5/AS:614301840707618@1523472380809/a-a-diagram-of-the-internal-anatomy-of-the-heart-with-the-impulse-conduction-pathway.png))

The figure 8 shows the complete internal anatomy along with the conduction system. The device has the same structure as the heart. The four valves were replaced with four **servo motors**. The conduction system nodes were denoted by **LEDs** as shown in figure 9. According to the rhythm the LEDs will glow and OFF. Different color LEDs were used to differentiate the nodes. Red – SA Node, Yellow – AV Node, Brown – Bundle of His, Green – Left & right bundles and purkinje fibers.

The device is turned ON by a simple slide switch. The potentiometer acts as a rhythm selector knob. For each level in the potentiometer, a different algorithm is coded. Normal/Tachy slide switch is to toggle fast rate rhythms. All these inputs were fed to the microcontroller(Arduino UNO) and processed. The Selected rhythm is displayed in **LCD display** and all those LEDs and servo motors function according to the rhythm selected.

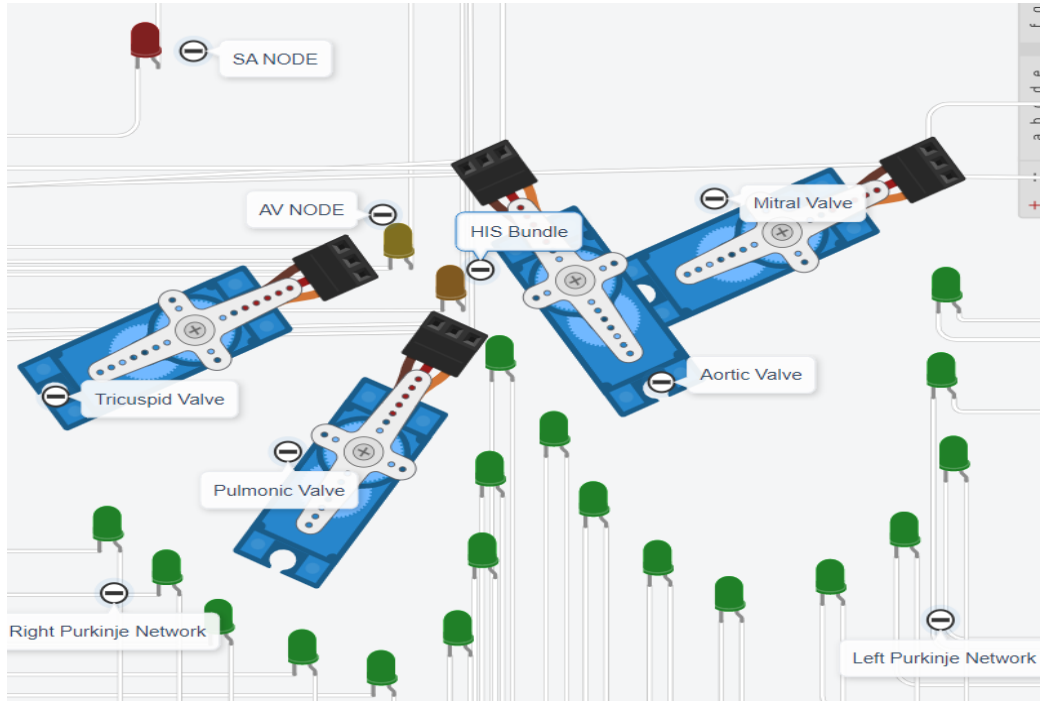

Fig.9. Snapshot of heart model of the proposed system.

The Potentiometer is a variable resistor, where we can adjust the resistance by turning the knob. For each position of the potentiometer, the resistance value will differ. So I used it as a rhythm selector knob. The rhythm selector knob

offers 7 menus. 1. Normal, 2. Junctional, 3. Ventricular rhythm, 4. Pulseless Electrical activity, 5. First Degree AV Block, 6. Second-degree Blocks, 7. Complete Heart Block. The final design of the model is shown in figure 10.

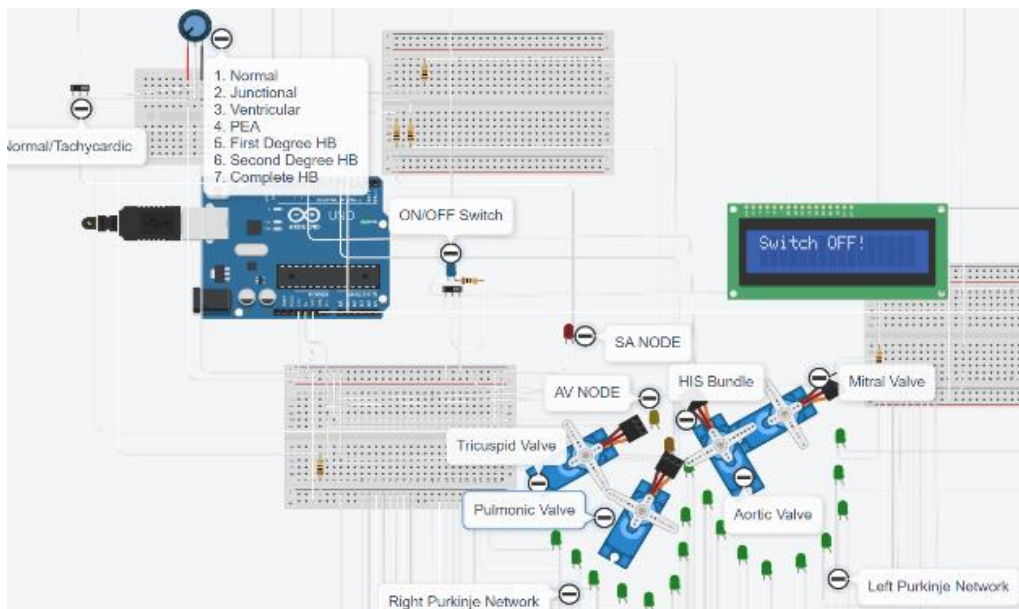

Fig.10. Snapshot of proposed design.

III. EXPERIMENT AND RESULTS

The model is tested with different inputs and were shown in below snapshots.

Normal Sinus Rhythm: Normal is selected in the rhythm

selector knob as shown in figure 11(a). SA node glows first (RED), AV node and Purkinje fibers LEDs glow after SA node initiation as shown in figure 11.1 (b) and (c).

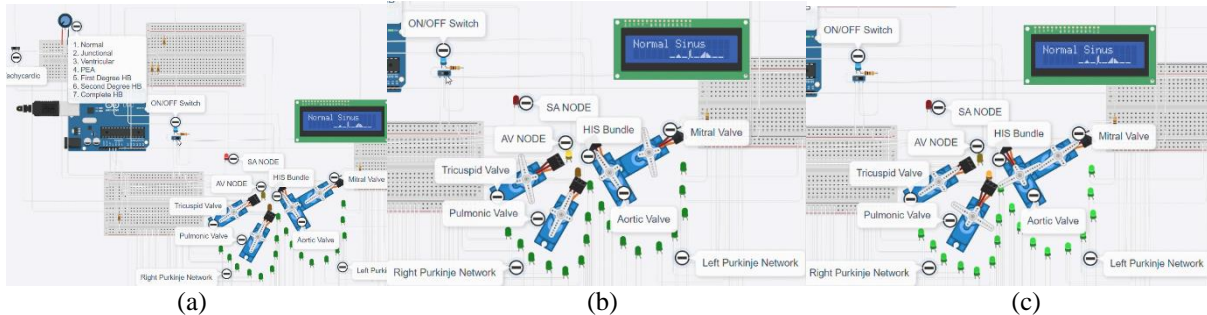

Fig.11.1. Snapshots of Normal Rhythm.

Normal Sinus Rhythm – Tachycardic: Tachycardic option is toggled with Normal/Tachy slides witch and the LEDs will ON and OFF at a faster rate.

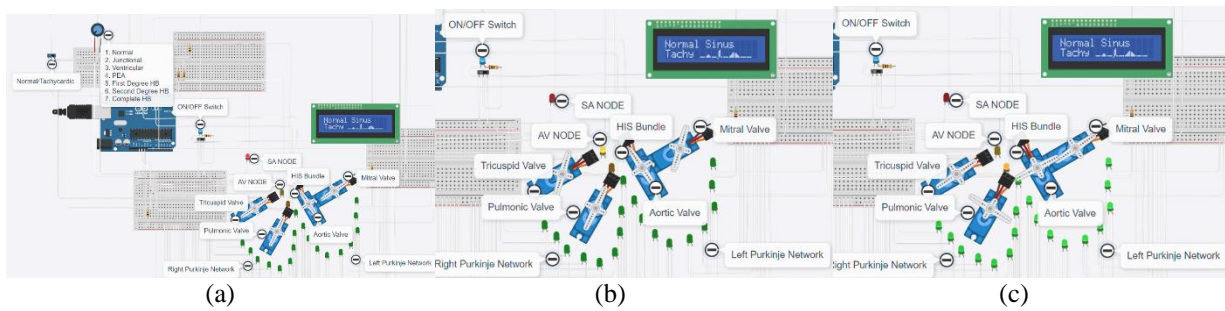

Fig.11.2 Snapshots of Normal Rhythm – Tachycardic

Junctional Rhythm: In Junctional, The SA node will not produce impulse. AV node take charge and initiate the conduction.

Junctional is selected in the rhythm selector knob as shown

in Figure 11.3(a). SA node LED will not glow and AV Node LED initiates the impulse and conducts as shown in figure 11.3(b) and 11.3(c).

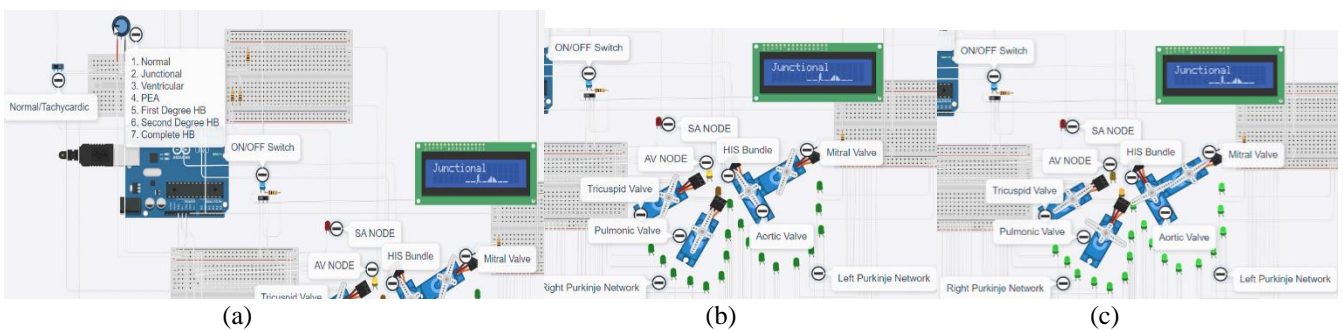

Fig.11.3. Snapshots of Junctional Rhythm.

Junctional Tachycardia: Tachycardic option toggled with normal/tachy switch and results in junctional rhythm with higher pace.

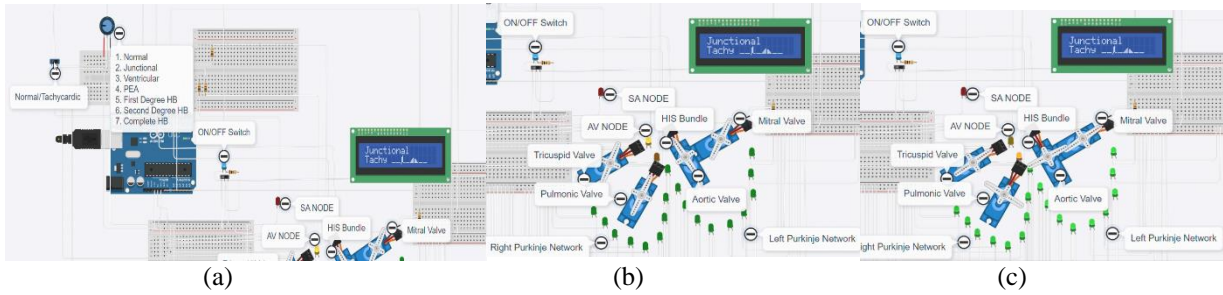

Fig.11.4. Snapshots of Junctional Rhythm – Tachycardic

Ventricular Rhythm: Ventricular Rhythm is chosen as shown in figure 11.5(a). In Ventricular rhythm SA and AV nodes fail and bundle branches take charge at a slow pace of about 40-60 BPM.

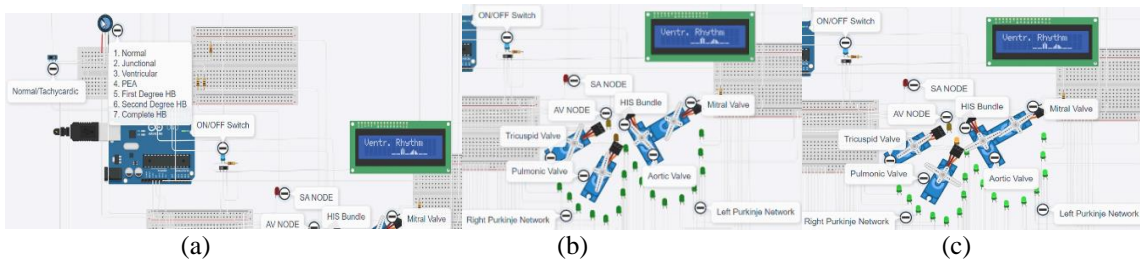

Fig 11.5. Snapshots of Ventricular Rhythm.

Ventricular Tachycardia: Ventricular Tachycardia is a lethal arrhythmia. Wide qRS rhythm with greater than 100 BPM.

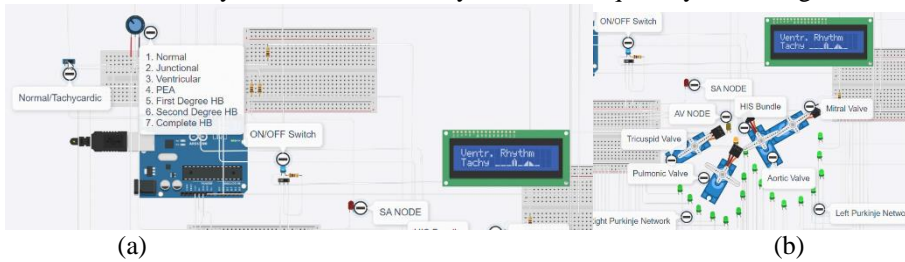

Fig 11.6. Snapshots of Ventricular Tachycardia.

Pulseless Electrical Activity – Sinus: Pulseless Electrical activity is a condition where the conduction system functions but the heart's mechanical system freezes as shown in figure 11.7.

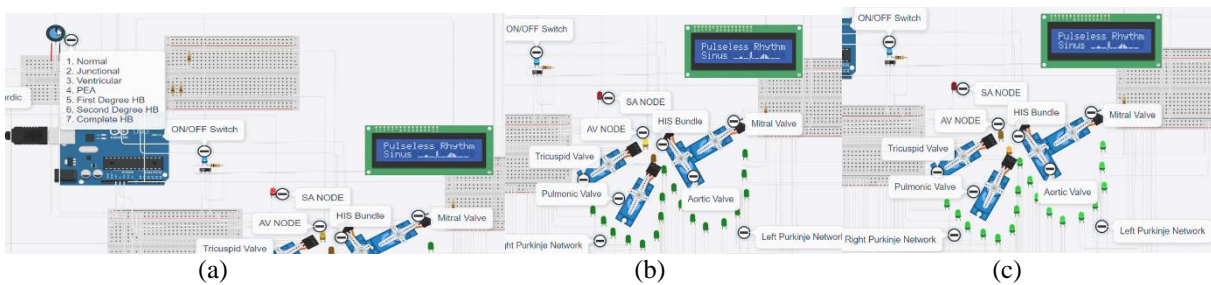

Fig 11.7 Snapshots of PEA-Sinus rhythm.

Pulseless Electrical Activity - VTach: Pulseless VT is a lethal arrhythmia and immediate defibrillation is needed.

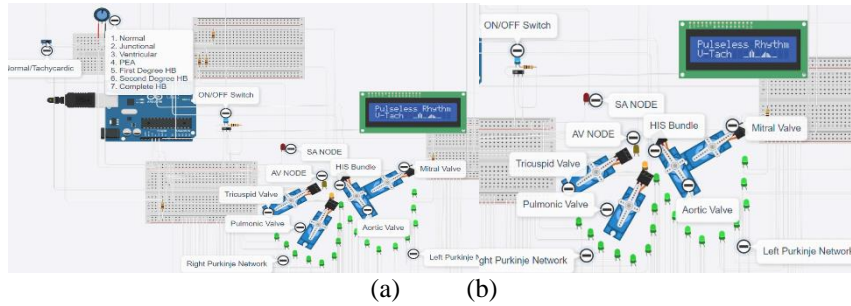

Fig 11.8 Snapshots of PEA- VTach

First Degree AV Block: In First degree AV Block, The PR interval is prolonged more than 200 milliseconds. The rhythm is similar to Normal sinus rhythm except for the PR interval.

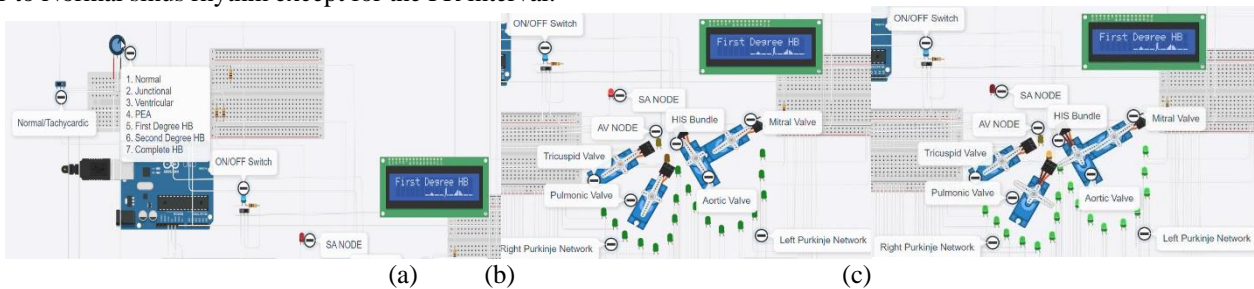

Fig 11.9. Snapshots of First Degree AV Block.

Second Degree AV Block Type 1: Second Degree Type I is characterized by constant PR interval changes and dropping of qRS complex. As you can see in Figure 11.10 (a) and (b) the impulse reaches the AV node and drops without ventricular conduction. Next impulse conducts the ventricles.

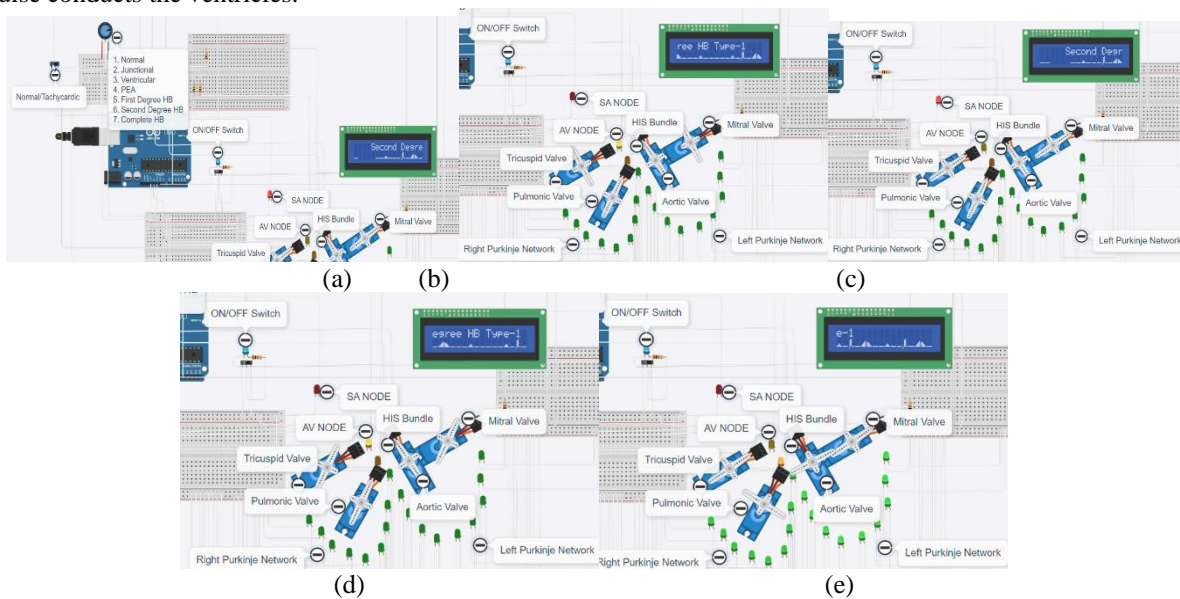

Fig.11.10. Snapshots of Second Degree AV Block Type 1.

Second Degree AV Block Type 2: In Second Degree AV Block, The PR interval remains constant and few impulses are non-conducted.

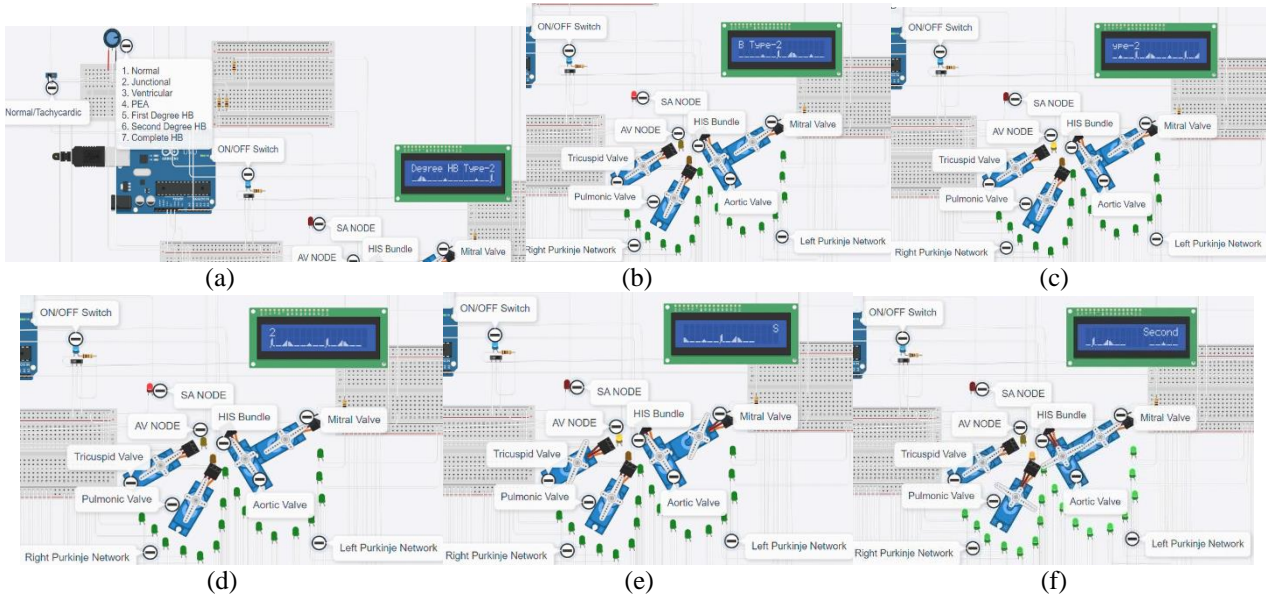

Fig.11.11. Snapshots of Second-degree AV Block Type II.

Complete Heart Block: In Complete AV Block/Third-degree AV Block, the SA node and bundle fibers initiate impulses asynchronously. All the impulses fire randomly and result in a Ventricular escape rhythm.

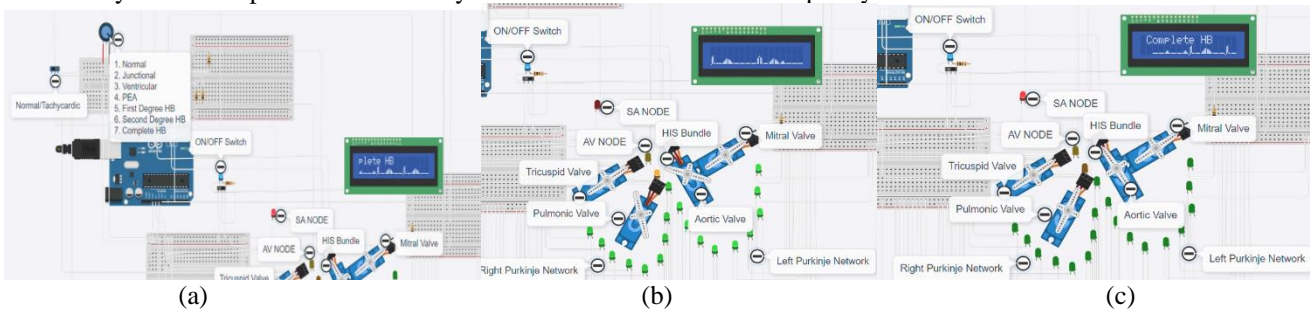

Fig.11.12. Snapshots of Complete Heart Block.

Switch Off: The device can be switched OFF by toggling the ON/OFF switch. It displays a flat line when switched off

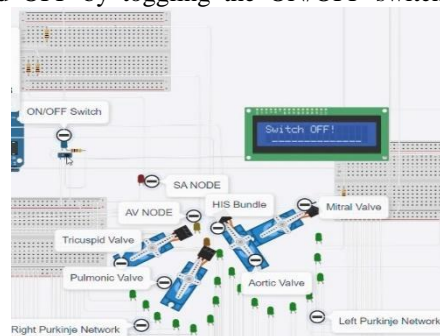

Fig.11.13. Switch OFF condition.

IV. CONCLUSION

The simulation device will help students to learn about the heart. I am looking forward to bring all the arrhythmia in this device and even other special heart related problems.

REFERENCES

- [1] Yasar Sattar, lovely chhabra, (2023). "Electrocardiogram" Stat Pearls – National library of medicine.
- [2] <https://openstax.org/books/anatomy-and-physiology>



- physiology/pages/19-1-heart-anatomy.
- [3] Sophie White, (2023). “The Conduction System of Heart” Teach me Anatomy.
 - [4] Philip Woodrow, (2010). “Emergency Nurse” Royal College of nursing publishing company – Vol. 18, issue 1.
 - [5] Anthony Dupre MS, Sarah Vincent MS, Paul A. Iaizzo PhD, (2005) – Handbook of Cardiac anatomy, physiology, devices. (pp.194-196).
 - [6] Ed burns and Robert Buttner, (2021). “Normal Sinus Rhythm” Life in the fast lane.
 - [7] <https://leveluprn.com/blogs/ekg-interpretation/7-junctional-rhythms>.
 - [8] Mahesh Kumar, Shivraj Nagalli, (2023). “Idioventricular Rhythm”- National Library of medicine.
 - [9] Steven Lome, “Ventricular Tachycardia – a review” – learn the heart.
 - [10] John Larkin and Robert Buttner, (2021). “First Degree AV Block” Life in the fast lane.
 - [11] Ed burns and Robert Buttner, (2024). “2nd Degree Mobitz 1” Life in the fast lane.
 - [12] Ed burns and Robert Buttner, (2024). “2nd Degree Mobitz 1I” Life in the fast lane.
 - [13] John Larkin and Robert Buttner, (2023). “AV Block 3rd Degree” Life in the fast lane.
 - [14] Chris Nickson, (2023). “Pulseless Electrical Activity” Life in the fast lane.
 - [15] Leo Louis, (2016). “Working principle of Arduino as a tool for study and research,” International Journal of Control, Automation, Communication and Systems, Vol.1, No.2.
 - [16] <https://arduinogetstarted.com/faq/how-to-use-special-character-on-lcd>.

IJEAST

INTERNATIONAL JOURNAL
OF ENGINEERING APPLIED SCIENCE
AND TECHNOLOGY

ABOUT IJEAST

International Journal of Engineering Applied Science and Technology (IJEAST) is a peer-reviewed, open access journal that publishes high-quality research papers in the field of Engineering, Applied Science and Technology.

IJEAST aims to provide a platform for researchers, academicians, and professionals to share their innovative ideas, research findings, and practical experiences with the global scientific community.

FOCUS AREAS

- Engineering
- Applied Science
- Technology
- Innovation & Development
- Interdisciplinary Studies



PEER REVIEWED

All submissions are rigorously peer reviewed to ensure quality.



OPEN ACCESS

Free and unrestricted access to research for all.



GLOBAL REACH

Connecting researchers and professionals worldwide.



TIMELY PUBLICATION

We ensure a swift and efficient publication process.



For more information, visit our website

www.ijeast.com



INTERNATIONAL JOURNAL
OF ENGINEERING APPLIED SCIENCE
AND TECHNOLOGY

✉ editor@ijeast.com

🌐 www.ijeast.com

📍 India



2455-2143