



# IJEAST

INTERNATIONAL JOURNAL  
OF ENGINEERING APPLIED SCIENCE  
AND TECHNOLOGY



**VOLUME : 5    ISSUE : 9    Print / Issue Publication Date: 21-Mar-2021**



**ISSN : 2455-2143**



**DOI : 10.33564/IJEAST.2021.v05i09.042**

Indexed In



[WWW.IJEAST.COM](http://WWW.IJEAST.COM)

[editor@ijeast.com](mailto:editor@ijeast.com)



# IOT - LIVESTOCK MONITORING AND MANAGEMENT SYSTEM

Justin Ophir Isaac

Dept. Computer Engineering

Vidyalankar Polytechnic

Mumbai, Maharashtra, India

**Abstract----- The intention of this research is to establish a platform or livestock monitoring and management system. The IOT framework provides IOT solutions in a wide range of domains and applications in farming, livestock, and agricultural front. The technology stack is based on the Internet of Things (IoT) with relevant sensors available to determine the dairy monitoring system to be placed on the animal. This document provides Use Cases (UC) of the domain, and performs evaluations in different conditions which are close to real-time scenarios and operational ones. With the IOT stack, with appropriate sensors for determining geographical boundaries, assets, interoperability, re-usability and functionality, the technical use-case is described in terms of entity/informational model, deployment view, functional view, business process hierarchy. This document provides detailed analysis of the flow of data and its interactions.**

**Keywords** — *Internet of Things; Wi-fi; Wireless; Sensors;*

## I. INTRODUCTION

THIS document details how use of I.O.T can help streamline and ease, what is a complex, round-the-clock job which becomes unmanageable with a large number of livestock.

### Internet of Things (IoT) :

IOT refers to a system of interconnected devices and or sensors that transmit and relay localized information and parameters over a closed or semi-open wireless network.

IOT is being leveraged in different verticals and domains to inter-relate data with new methodologies and technologies used to fulfill the requirements. IoT offers a wide range of connectivity of devices with various protocols like MQTT, HTTP(s) and various properties of applications for automating applications and connect machines.

IOT has changed the field of home automation, wireless sensor networks and control systems to make it efficient, smarter using smart wristbands, navigation pills, etc. All these methods require an internet connectivity and interfaces to update the health info or to control the device with a smartphone.

The manufacturing processes also require IoT for supply chain management, digital control systems for monitoring the manufacturing processes.

Using the IOT stack, the geographical boundary can be defined for tracking objects in space. Nowadays, cars are equipped with IOT sensors which determine the current fuel of the vehicle, the speed of the vehicle and connected to the centralized IOT platform which based on the patterns predict the vehicle maintenance, shortest path the destination, traffic monitoring systems. Similarly, using the IOT sensors and using predictive maintenance, there is an increase in ROI within a short period of time.

**Herd Monitoring:** Sensors attached to the livestock collars define the geo-fencing capabilities and track your herd via GPS. Various local parameters like speed, its body temperature, location, stress levels of livestock are the real-time attributes being tracked. It reduces inefficiencies, decreases operating costs and improves the health, safety of livestock. Using appropriate sensors considering physical and environmental parameters, the response time provided by the system is high thereby providing accurate results and provide a high ROI for implementing this system to manage the herds.

**Herd Safety:** Securing the gates to deter theft of livestock with appropriate rugged, tamper-proof devices that are smart to differentiate between human and animal movement. All the gates can be remotely monitored from a single dashboard. Visual assessment (phenotypic) selection uses appropriate pattern recognition to identify an animal based on its body conformation, size, posture, color, udder and testicle size and placement of different parts.

Genetic assessment (genotypic) is based on known inherited characteristics and historical facts which are influenced by an animal's genetic characteristics.

This is done by genetic evaluation methods such as Estimated Breeding Value (EBV) or Expected Progeny Difference (EPD). Important traits like reproductive efficiency, growth rate, carcass quality, parasite resistance can be predicted using the above evaluation methods.

**Herd Location Monitoring:** Animals are equipped with a BLE (Bluetooth Low Energy) beacon attached near the ears



which are Locator nodes. These signals transmit the latitude/longitude coordinates remotely to the Centralized Location Aware Platform. The data is processed and the positions of the animals are determined. BLE beacons with special sensor functions are used to generate customization reports; historical data can be evaluated and compared with the real-time data at any time.

Using the location/region of the livestock grazing, predictive alerting can be determined using the weather API and provide the targeted climate of the stable.

## II. LITERATURE SURVEY

With the introduction of IOT developments in technology space and with appropriate insights, the document captures the required architectural aspects with international standards and provide a high level view of the system. The use-case pertaining to Livestock monitoring is explained with appropriate entity models, functionality being captured and how the deployment can be done in small, medium and large deployment area. It also highlights the insights of the main endpoints and provides an appropriate gap analysis to this front. From herd management to farm management to people management, challenges are navigated on a daily basis. Proactively detecting and treating diseases in livestock is a challenge. Earlier the trained employees were able to detect the problems at the early stage and provide corrective recourse actions so that the disease is not spread and it is controlled. With Milking Point controllers and Milk Yield Recording parameters, the metadata collected at regular intervals of time and artificial intelligence build, it provides a daily insight on the milk production and health data can be analyzed further. With the technology in place and decision in hand, it would provide a clear insight on the production limits and increase the ROI of investments made. With the insight available, the system would alert for conductivity problems so we can detect diseases in an early stage and take actions which would in-turn, avoid losses in terms of milk production or early culling.

Milking Point devices facilitate milk harvest of every cow and records operations like Start and End of the milking process, Cleaning, Take off, Pulsation control, Entry/exit gates. The system provides loosely coupled integration to third party applications like Inventory, Dairy management system and other systems which wants to make sense of this metadata. These metadata helps to predict in the milking parlor and regulate separation. This also provides actionable insights, saving time and bringing convenience and control.

## III. SYSTEM ARCHITECTURE

**Grazing Monitor** - The objective of this use case is to monitor the grazing of the livestock automatically in the context of ammonia emission reduction and marketing of

‘pasture milk’. Technically this can be achieved by using a tracker module with BLE technology. This helps us to verify the number of hours the livestock has spent on the pasture and deduce the ammonia emission reduction. Belgium and Netherlands are the countries where these technologies are coming up and they have some specific challenge to take up.

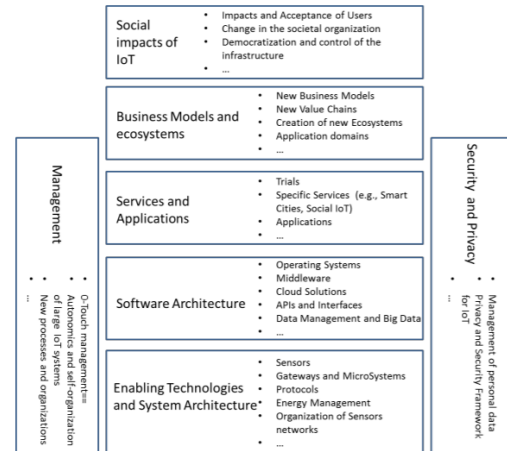

Fig 1: Technological and social aspects related to IoT

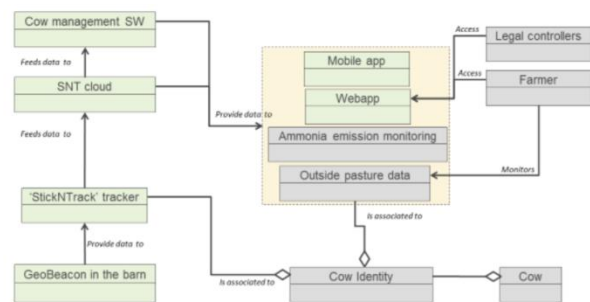

Fig 2: Grazing Cow Monitor Use Case

To monitor the duration of outdoor grazing of individual cows, an IOT enabled sensor is installed on the collar of each cow which is associated with the cow unique identifier. The sensor provides the lat/long co-ordinates of the cow when the movement happens. The data is sent to the Central Application cloud to be stored and runs algorithms on these data and provides insight data to the application. The grazing duration and the ammonia emission monitoring are quantitative and provides a well defined chart specific to the individual cow and its health.

### A. Deployment View

The IOT tracker device is installed on the cow collar and the beacon reader is placed inside the barn. The sensor emits its Geo-location information directly from GPS to the API hosted on the Cloud. The milk produced, all behavioral data and also sent to the Cloud Service Platform through the link where the data are stored on the component Central IOT Application Cloud. The web apps and mobile apps provide insights with charts and graphs using the data stored on the Application

Cloud.

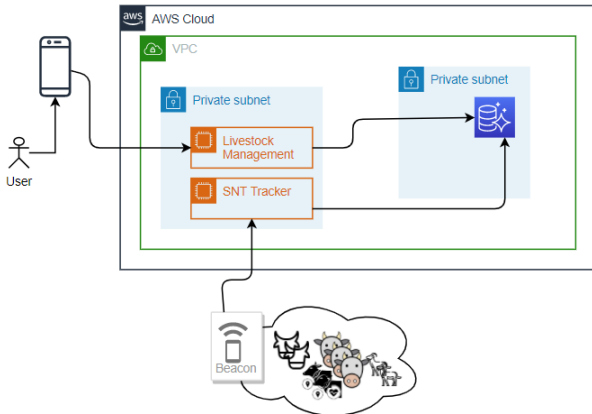

Fig 3: Deployment View

Name	Description	Supplier (brand) + Model	Number of Units
SitNTracker	Location Tracker	GPS SIT PRO Brand: Globalstar	240
Geo beacon	Indoor location tracker	SNT GEObeacon Brand: Globalstar	1-5
AWS IOT	IoT Platform	AWS cloud Supplier: Amazon	1
IOT App	Admin app for managing	Webapp	3 subscription based
Mobile app	Dashboard / Reports	Android/IOS mobile app	Download
Livestock Management App	Integration	Selection by User	1

**B. Business Process Hierarchy View**

Physically, the produced milk can be said pasture milk depending on the cow position and barn status which are relevant for the farmer. Based on the data collected it is possible to measure the emissions, thereby defining the score. Hence with the help of the controller layer the farmer controls the livestock based on the position and barn status. The data collection and data analysis are performed during the ingestion of the metrics which is collected. Using the application layer, the information regarding evidence of pasturing is provided, which affects emission reduction management and milk management.

**C. Information Model**

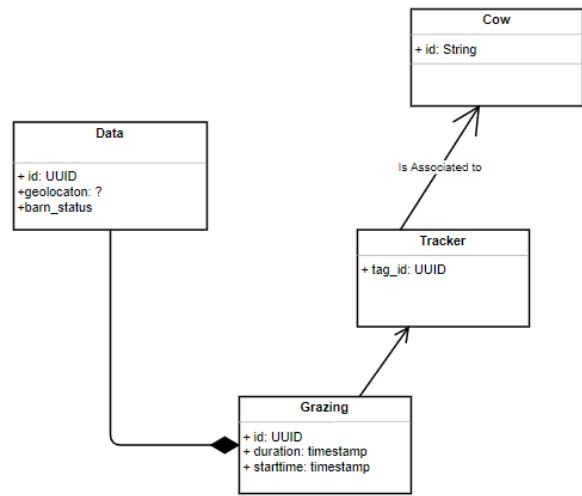

Fig 4: Information model

**D. Security, Privacy and Trust Analysis**

Data is the key. Security of the application is a key concern when the application is deployed on the cloud. This provides a platform for multiple clients who can store the livestock data on the cloud in a multi-tenant model. Hence privacy and security of the data becomes the de-facto model which has to be supported by the application. Hence security concerns must be addressed from the beginning of a project development and not after the final design.

**E. Summary of gaps**

Here is the gap analysis on the system being implemented which can be taken a future enhancements in the road-map. These specific gaps has been identified and listed below:

- 1.The process for the on-boarding of a cow with the IOT device on the cow collar still needs to be documented and implemented.
  - 2.The connectivity of the devices to the Cloud platform based on protocol like MQTT, Http(s) has to be documented.
  - 3.The User interface of the Mobile app also needs to be defined.
  4. The development stack of building the Mobile app is not yet finalized.
- Some deployment/field test area still needs to be identified.

**F. Sensors**

Wireless Sensor Networks are created for tracking of animal location, temperature changes, pasture utilization which prevents livestock thefts using Geo-location, understanding of animal behavioral patterns, weather details in real-time. Heat-map is generated so that there is no interference of data due to obstacles. This generates a lot of data on which analysis can be run to find anomalies to infer new things in future.



*G. Abbreviations and Acronyms*

BLE: Bluetooth Low Energy  
EBV: Estimated Breeding Value  
EPD: Expected Progeny Difference  
IoT: Internet of Things  
MPC: Milking Point Controllers  
SNT: SitNTrack  
UC: Use Case

**IV. CONCLUSION**

The document outlines the high level requirements and establishes the IoT technical stack to achieve the resultant system to track livestock and manage the entire process remotely. The Use Case is kept in a simple and clear structure, with detailed investigations and gaps analysis.

**V. REFERENCES**

[1] P.Kibame Mashoko NKWari, S.RIMER and B.S.PAUL - 'Cattle Monitoring System Using Wireless Sensor Networks in order to prevent Cattle Rustling'

[2] J.Yick, B.Mukherjee and D.Ghosal, "Wireless sensor network survey," *Computer Networks*, vol. 52, p.2292-2330, 2008.

[3] Kondamudi Siva Sai Ram1 , A.N.P.S.Gupta2 1 PG Scholar (VLSI&ES) in Narasaraopet Institute of Technology, Narasaraopet, Andhra Pradesh, India 2 Assistant Professor (ECE) in Narasaraopet Institute of Technology, Narasaraopet, Andhra Pradesh, India.  
"IoT based Data Logger System for weather monitoring using Wireless sensor networks" *International Journal of Engineering Trends and Technology (IJETT)* – Volume 32 Number 2- February 2016.

J. Yick, B. Mukherjee and D. Ghosal, "Wireless sensor network survey," *Computer Networks*, vol. 52, p. 2292–2330, 2008.

[4] Alexey Chalimov, CEO at Eastern Peak, "IoT in Agriculture: 8 Technology Use Cases for Smart Farming (And Challenges To Consider)". Alexey Chalimov / 7<sup>th</sup> July, 2020 / Trends

[5] Amruta Awasthi, Anshul Awasthi, Daniel Riordan, Joseph Walsh. "Non-Invasive Sensor Technology for the Development of a Dairy Cattle Health Monitoring System". School of Science, Technology, Engineering and Mathematics, Institute of Technology Tralee, Tralee V92 CX88, County Kerry, Ireland. *Computers* **2016**, 5(4), 23 (Theory, Design and Prototyping of Wearable Electronics and Computing)

[6] Lead editors: R. Tomasi, F. Rizzo, D. Conzon (ISMB)  
Other major contributors: H. Sundmaeker, G. Große Hovest, A. Vyas (ATB); J. Berg, F. Manoel (NXP).

"Internet of Food and Farm 2020"

[7] Mohammad Afaneh, "Wireless Connectivity Options for IoT Applications – Condition Monitoring". July 17, 2020 Bluetooth Blog.

[8] Mohammad Afaneh, "Wireless Conectivity Options for IoT Applications – Technology Comparison". April 21, 2020 Bluetooth Blog.

[9] Mohammad Afaneh, "Wireless Conectivity Options for IoT Applications – Terms and Applications". April 21, 2020 Bluetooth Blog.

[10] Winjit Technologies, "Innovative IoT for Happy Cows" – 2017 - IoTSense

# IJEAST

INTERNATIONAL JOURNAL  
OF ENGINEERING APPLIED SCIENCE  
AND TECHNOLOGY

## ABOUT IJEAST

International Journal of Engineering Applied Science and Technology (IJEAST) is a peer-reviewed, open access journal that publishes high-quality research papers in the field of Engineering, Applied Science and Technology.

IJEAST aims to provide a platform for researchers, academicians, and professionals to share their innovative ideas, research findings, and practical experiences with the global scientific community.

## FOCUS AREAS

- Engineering
- Applied Science
- Technology
- Innovation & Development
- Interdisciplinary Studies



### PEER REVIEWED

All submissions are rigorously peer reviewed to ensure quality.



### OPEN ACCESS

Free and unrestricted access to research for all.



### GLOBAL REACH

Connecting researchers and professionals worldwide.



### TIMELY PUBLICATION

We ensure a swift and efficient publication process.



For more information, visit our website

[www.ijeast.com](http://www.ijeast.com)



INTERNATIONAL JOURNAL  
OF ENGINEERING APPLIED SCIENCE  
AND TECHNOLOGY

✉ [editor@ijeast.com](mailto:editor@ijeast.com)

🌐 [www.ijeast.com](http://www.ijeast.com)

📍 India



2455-2143