



IJEAST

INTERNATIONAL JOURNAL
OF ENGINEERING APPLIED SCIENCE
AND TECHNOLOGY



VOLUME : 6 ISSUE : 10 Print / Issue Publication Date: 21-Apr-2022



ISSN : 2455-2143



DOI : 10.33564/IJEAST.2022.v06i10.033

Indexed In



WWW.IJEAST.COM

editor@ijeast.com



SMART SURVEILLANCE SYSTEM WITH FACE RECOGNITION USING OPEN-SOURCE COMPUTER VISION

Venkatesh Devarapalli, Patcha Ashok Chakravarthi, Nandiki Samuel Nissi
Department of E.C.E.,
Godavari Institute of Engineering and Technology (A),
Rajahmundry, India

Udhay Kumar Reddy Mallu
Department of Computer Science,
Lovely Professional University,
Phagwara, India.

Abstract—The current project is primarily concerned with ensuring a secure environment and also free from the hold-ups that occur in your surroundings. This automated surveillance system detects intruders using various devices with software. The major software employed in the current work is Open CV (open-source computer vision). The primary method utilized in the present work is if any person appears in front of the pi camera. It will switch on by observing for probable matches that have previously been stored in our database. If the module finds a match, then it continues to record until an intruder comes. If the face is not recognized then the unknown person's face will be captured and a snapshot will be sent to the user's email. The device is developed using Raspberry Pi with a 1.4 GHz quad-core processor, a raspberry pi camera with 12MP high-resolution, and a Wireless dongle to communicate with users' email. For motion detection, most existing systems employ a Passive Infrared (PIR) motion sensor. Despite its inexpensive cost, such a system has some demerits. For example, as a result of an exceptional situation, such as rapid heating induced by sun exposure, false alarms may be triggered. To increase the efficiency of motion detection, a smart surveillance system is constructed using Open CV on a Raspberry Pi 3 Model B. According to the findings, the built smart surveillance security system using Open CV has a detection rate of 96%, whereas the PIR motion sensor-based security system has a detection rate of 76%.

Keywords—: Database, Open CV, Pi camera, Passive Infrared motion sensor, Raspberry Pi, and Wireless dongle.

I. INTRODUCTION

Biometric systems offered an extra layer of security to networks, apps, personal computers, and physical facilities by comparing the binary code of a person's physical or biological feature to the binary code electronically stored in the system. Contact-based biometric systems include fingerprints, palm prints, hand geometry, and signatures. Contactless biometric systems use the face, iris, voice, and gait. The most extensively used biometric system today is the fingerprint method, in which people just punch in their thumbs and the authentication is completed. In government agencies, signature biometrics are widely employed. However, the problem with these systems is that the handshape changes. Our hands have ridges, valleys, curves, primary lines, and wrinkles that change throughout time to some extent. Environmental factors like as dry weather, dirty or smudged hands and wet hands can also make authentication difficult. As a result, people began to adapt to contactless biometric systems, in which no physical contact is made with the system. Iris, voice, and gait recognition each have their own set of advantages and disadvantages. However, in this paper, we have chosen to focus on the most well-studied subject of face recognition. Face recognition has quickly made its way into the real world, proving to be the most successful and up-to-date technology that is no longer limited to science fiction. It can be used as a surveillance system, a criminal identification system, an identity verification access or attendance system, a home automation system, and so much more. Face recognition technology has progressed dramatically from 2D algorithms such as PCA, Eigen faces, Fisher faces, LDA, IDA, to SVM, CNN, and now deep learning, machine learning, and artificial intelligence.

A great thank you to the new and well-developed computer science technologies that allow us to get significant features for identifying purposes. Face recognition is started in this

paper by pressing the doorbell. This will activate the built-in camera and allow you to take pictures. The taken image will be compared to the one in the backend database. The name of the person on the doorstep will be announced if the two are matched. If the face does not exist in the database, it will be stored newly. This makeshift doorbell, unlike the old standard doorbell, alerts us to who is at the door. This will be beneficial to people with disabilities, especially the blind. In Section 3 of the article, the system design is discussed. The implementation architecture and experimental findings are covered in sections 4 and 5.

A. Face Detection: An algorithm searches for faces in a given input, such as video or images, and then cleans the faces with various filters before further processing.

B. Face Recognition: The Face Detection algorithm's output is fed into the Face Recognition algorithm as input. The given input is evaluated, and the algorithm searches the database for a face that looks similar to determine who the individual is.

Face detection differs from face recognition in that the former determines whether or not there is a face in the input image or video, whereas the other determines which face it is. Face detection is used in the proposed system to determine whether a human is present in the scene, and if a face is detected, the face is cropped along the axis of the bounding box and transmitted to the user as an email or MMS. The Raspberry PI is a credit card-shaped microcontroller that performs similarly to a computer. There are numerous surveillance methods [3], such as cameras and "C.C.T. V," but they require a person to monitor activity via monitors and the storage and scaling of the storing unit must be maintained. Because we employ cloud storage, the suggested method eliminates the requirement for storage, and scaling is not an issue with cloud storage.

II. EXISTING METHODOLOGY

Face detection and identification have progressed from obscure to prominent fields of computer vision research in the last decade and are now one of the better and more effective uses of picture analysis and algorithm-based understanding. Because of the inherent nature of the problem, computer vision is the subject of both computer science and neuroscientific and psychological research, owing to the widespread belief that advances in computer image processing and understanding research will provide insights into how our brains work and vice versa. The following is a generic formulation of the face recognition problem (in computer vision): Using a stored database of faces, identify or verify one or more people in a scene



Fig 1: Normal Surveillance System

Facial recognition is usually divided into two stages: Face Detection is a technique that involves searching a photo for a face, then processing the image to crop and remove the person's face for better recognition. Face Recognition is the process of comparing a detected and processed face to a database of known faces to determine who that person is.

Face identification has been relatively easy and reliable with Intel's open-source framework, Open CV, since 2002. Face Detection is included in this framework, and it works in around 90-95 percent of clear photographs of a person looking directly at the camera. However,

recognizing a person's face when viewed from an angle is frequently more difficult, requiring 3D Head Pose Estimation in some cases. Also, a lack of sufficient image brightness, or greater contrast in shadows on the face, or perhaps the picture is grainy, or the individual is wearing glasses, can considerably enhance the difficulty of distinguishing a face.

Face recognition, on the other hand, is far less accurate than face detection, with a general accuracy of 30-70 percent. Since the 1990s, face recognition has been a hot topic of research, but it is still a long way from being a solid method of user verification. Each year, more and more techniques are produced. Many additional (far more sophisticated) methods or combinations of many ways are marginally more accurate than the Eigenface methodology.

Gary Bradski founded OpenCV at Intel in 1999 to speed up research and commercial applications of computer vision around the world while also driving demand for ever more powerful computers for Intel. Gary hired Vadim Pisarevsky to lead Intel's Russian OpenCV software team. The OpenCV team has since gone on to other companies and research projects. Several members of the initial crew went on to work in robots and eventually ended up at Willow Garage. Willow Garage saw the need to rapidly enhance robotic perception skills in an open manner that benefits the whole academic and commercial community in 2008 and began actively promoting OpenCV, with Gary and Vadim once again leading the charge.

Intel's open-source computer vision library can make computer vision programming a lot easier. Face detection, face tracking, face recognition, Kalman filtering, and several artificial intelligence (AI) approaches are all included in a ready-to-use format. It also supports several fundamental computer-vision techniques through its lower-level APIs. OpenCV has the benefit of being a cross-platform framework, as it runs on Windows, Linux, and, more recently, Mac OS X. OPENCV has so many features that it can be intimidating at first. The key to getting good results using OpenCV is to have a thorough understanding of how these approaches function. Fortunately, just a few must be learned ahead of time to get started. The functionality of OpenCV that will be used for facial recognition is split up into many components. Here's a quick rundown of the most important namespaces: Basic data type definitions, linear algebra and statistics algorithms, persistence routines, and error handlers are all found in the CXCORE namespace. Surprisingly, the graphics functions for sketching images are also found here. Image processing and camera calibration methods are found in the CV namespace. This is also where you'll find the computational geometry functions. In OpenCV's documentation, the CVAUX namespace is characterized as holding obsolete and experimental code. This module, on the other hand, contains the most basic face recognition interfaces. Face recognition is a specialty of the code underlying them, and it's extensively employed for that reason.

Machine learning APIs are found in the ML namespace. The basic I/O interfaces and multi-platform windowing capabilities are found in the High GUI namespace. On 32-bit Windows platforms, the CVCAM namespace includes APIs for video access via DirectX.

III. PROPOSED METHODOLOGY

When it comes to image quality, there is a slew of variables that influence the system's accuracy. To standardize the photos, you submit to a face recognition system, you must use a variety of image pre-processing techniques. Most facial recognition algorithms are particularly sensitive to lighting conditions, so if it was taught to recognize a person in a dark room, it is unlikely to do so in a bright room, and so on. The problem is known as "lighting dependent," and there are numerous other issues, such as the face being in a very consistent position within the images (for example, the eyes being in the same pixel coordinates), consistent size, rotation angle, hair and makeup, emotion (smiling, angry, etc), and position of lights (to the left or above, etc). This is why, before using face recognition, it's critical to utilize good image pre-processing filters. You should also remove any pixels around the face that aren't being used, such as using an elliptical mask to only show the inner face region, rather than the hair and image background, because they change more than the face.

A Haar Cascade classifier is used by OpenCV to detect faces. The face detector evaluates each picture position and classifies it as "Face" or "Not Face" given an image, which can originate from a file or live video. The face is classified using a fixed scale of 50x50 pixels. Because faces in a picture may be smaller or larger than this, the classifier searches the image multiple times for faces at various scales. This may appear to be a lot of work, but thanks to algorithmic strategies outlined in the sidebar, categorization can be done quickly, even when performed at many scales. The classifier decides how to classify each image location based on information supplied in an XML file. Four types of XML data for frontal face detection and one for profile faces are included in the OpenCV download. There are three non-face XML files included as well: one for full body (pedestrian) detection, one for the upper body, and one for the lower body.

3.1 Block Diagram

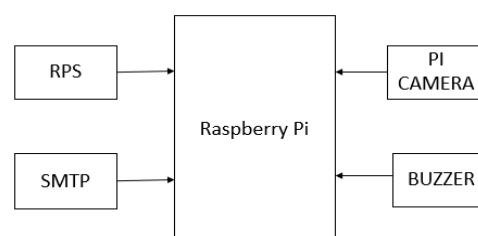

Fig 2: Block Diagram of smart surveillance system

A. Raspberry Pi

The Raspberry Pi 3 (RPi3) is a single-board computer with an ARM processor (SBC). It's also known as a credit-card-sized computer. Because of its dimensions, it is called such (86.9mm x 58.5mm x 19.1mm). This versatile single-board computer is the size of a credit card and may be used for a variety of tasks. It is essential for the advancement of Internet of Things (IoT) projects. These days, the Raspberry Pi 3 is being used as a testbed for IoT projects. The device's affordability and ease of use make it accessible to everyone. Raspberry Pi 3 can be used as a desktop computer, a media center a retro gaming machine, a robot controller, and even for facial identification.

The raspberry pi runs on the Raspbian operating system (Debian Linux OS).

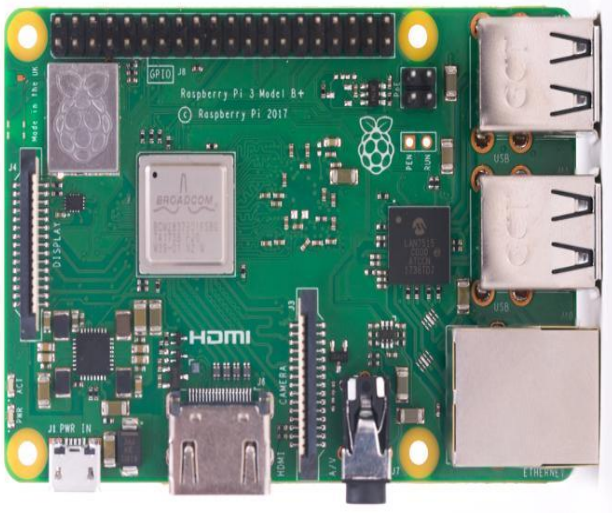

Fig 3: The Raspberry Pi board

B.Regulated Power Supply (Rps):

We have a power supply with +5V and -5V options in this project. Normally, +5V suffices for the entire circuit. In the case of an OP amp circuit, a different (-5V) supply is employed.

The primary winding of the transformer has a 230/50 Hz AC voltage, while the secondary winding has a 12/50 Hz AC voltage, which is then rectified using two full-wave rectifiers. The rectified output is then sent into a filter circuit, which filters out the undesirable ac in the signal.

The output is then applied to an LM7805 (toprovide+5v) regulator once again. LM7905, on the other hand, is used to provide -5V control. Stepper motors, fans, and relays are powered by the Z (+12V circuit, which uses the same LM7812 regulator as the above supply).

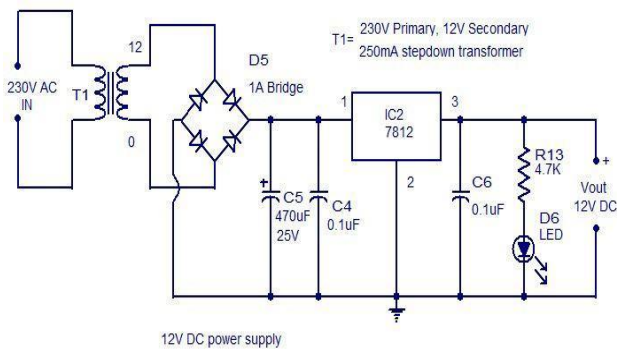

Fig 4: Regulated power supply

C. SMTP

The Simple Mail Transfer Protocol (SMTP) is a program that allows senders and receivers to send, receive, and relay emails. When an email is sent, it is sent over the internet

using SMTP from one server to another. Simply put, an SMTP email is sent over the SMTP server.

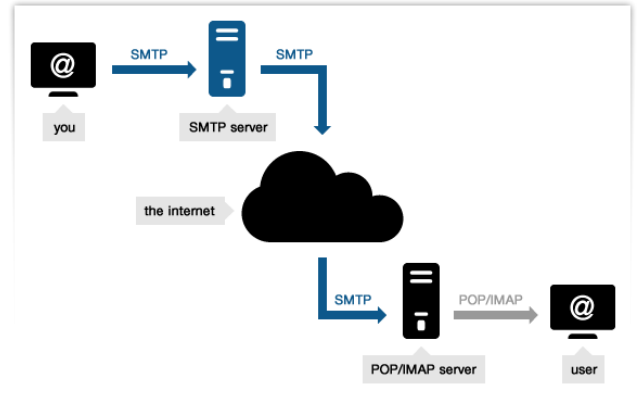

Fig 5: simple mail transfer protocol

D. PI CAMERA

The Pi camera module is a small, light camera that works with the Raspberry Pi. The MIPI camera serial interface protocol is used to communicate with the Pi. It's commonly utilized in image processing, machine learning, and surveillance applications.

The Pi Camera module is a camera that can snap photos and record high-definition video. The CSI (Camera Serial Interface) interface on the Raspberry Pi Board allows us to directly connect to the Pi Camera module. Using a 15-pin ribbon cable, this Pi Camera module may be connected to the Raspberry Pi's CSI port.

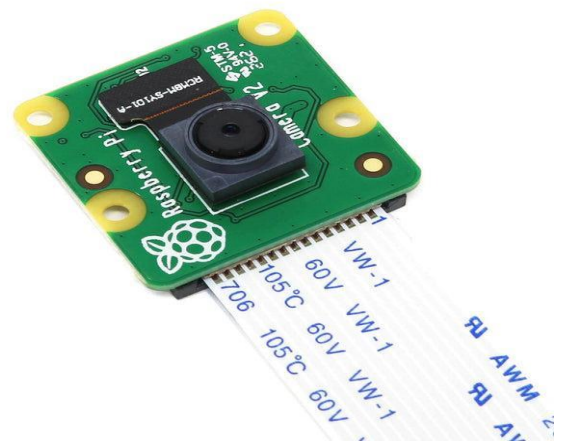

Fig 6: Pi Camera

E. Buzzers

A buzzer is similar to an alarm clock. When we hit the switch button, it produces an output that sounds like an alarm and then turns on the machine. Two pins make up the buzzer. The microcontroller's data pin is attached to the negative end. The microcontroller's Vcc is connected to the positive end.



Fig 7: Buzzer

F. OPEN-CV

The acronym OpenCV refers to the Open-Source Computer Vision Library. It's an open-source computer vision and machine learning software library. It was created to make the resource used by computer vision programs easier to use. It also has the benefit of obtaining machine perception.

To establish levels, we imported the Operating System for training data. Face recognition defines the number of functions. py, which is used for common functionality and is necessary for module import. For testing all of these modules, one more py file is necessary. The photos were captured in grayscale. Because the process is simplified and resource requirements are reduced, grayscale representations are required for extracting the descriptors. The Haar-Cascade classifiers were used to extract the features. We obtained the Haar-Cascade XML file from Google and saved it in a directory. We discovered that it has several traits stored in it. We'll be able to detect faces with the help of this classifier.

IV. RESULTS AND DISCUSSION



Fig 8: Smart Surveillance system

4.1 DISCUSSION

The goal of this thesis is to create a facial recognition model and use it to apply A.I. on an ARM-based IoT device using a Docker image. Based on the training and dataset, this model can make decisions. The implementation was carried

out using the Python programming language and a variety of deep learning-based modules and packages. The A.I. model for face identification is based on *dlib*, a state-of-the-art deep learning face recognition library written in C++. Our approach has a recognition success rate of around 93 percent.

This A.I. model was trained and tested with a variety of people, and the findings demonstrate that the AI model correctly identified the images. This AI model was chosen for the thesis since it is open source and does not require vendor lock-in. In comparison to other facial recognition models, this one provides the most flexibility in terms of changing according to the requirements and is the easiest to apply.

V. CONCLUSION

To begin, we gathered data from Kaggle and the UCI repository. We later employed customized datasets created by our buddies. We've taken seventy photos for practice. We have an average accuracy level of 77 percent. We concluded that, as a result of the emergence of several computer vision applications, facial recognition has become a survey. This is a description of the visual perception and autonomy module project. It then goes on to detail the project's technologies and processes. Finally, it displays the results and discusses the issues. Face detection using the Haar-cascades algorithm performed exceptionally well, even when the subjects wore spectacles. The real-time video speed was also good, with no obvious frame latency. LBPH (Linear Binary Pattern Histogram) algorithm paired with Haar-cascades can be used as a cost-effective face identification platform when all parameters are taken into account. The computational models used in this work were picked after a thorough investigation, and the successful testing results demonstrate that the researcher's decisions were sound. Because of the small number of eigenfaces employed in the PCA transform.

VI. FUTURE SCOPE

This containerized AI model can be used on AI platforms such as Bonseyes, which aims to use AI in IoT and edge computing. Finally, though the face recognition system developed in this thesis only uses still photos as 61 datasets, taking a video as an input and detecting a human's face by extracting and encoding faces from a video sequence could be considered for future study. The advancement of use cases such as an AI model that can comprehend human behaviour and make intelligent judgments, as well as provisioning and automation. Using orchestrators such as Kubernetes to ensure high availability and scalability according to the application's needs.



VII. ACKNOWLEDGEMENT

We are grateful to Mr. J. MAHESH KUMAR, Assistant Professor(E.C.E)for having allowed carrying out this paper work. We take this opportunity to express my profound and whole heartfelt thanks to our guide, who with his patience support and sincere guidance helped us in the successful completion of the paper. We would like to thank Dr. B. Srinivasa Raja, Professor and Head of Department (ECE), for valuable suggestions throughout our paper which have helped in giving define shape to this work. We are particularly indebted to him for his innovative ideas, valuable suggestions and guidance during the entire period of work and without his unfathomable energy and enthusiasm, this paper would not have been completed. We like to express my deep sense of gratitude to Dr. P.M.M.S. Sarma, Principal of GODAVARI INSTITUTE OF ENGINEERING AND TECHNOLOGY (A), for providing us a chance to undergo this paper in a prestigious institute.

VIII. REFERENCE

- [1]. N. Intrator, D. Reisfeld, and Y. Yeshurun, "Face recognition using a hybrid supervised/unsupervised neural network," *Pattern Recognition Letters*, p. 10, 1996.
- [2]. S. Lawrence, C. L. Giles, A. C. Tsoi, and A. D. Back, "Face recognition: a convolutional neural-network approach," *IEEE Transactions on Neural Networks*, vol. 8, no. 1, pp. 98–113, Jan. 1997.
- [3]. S. A. El-said, "Reliable Face Recognition Using Artificial Neural Network," *Int. J. Syst. Dyn. Appl.*, vol. 2, no. 2, pp. 14–42, Apr. 2013.
- [4]. Shang-Hung Lin, Sun-Yuan Kung, and Long-Ji Lin, "Face recognition/detection by the probabilistic decision- based neural network," *IEEE Transactions on Neural Networks*, vol. 8, no. 1, pp. 114–132, Jan. 1997.
- [5]. Panthangi Sai Lohith, Gundoji Shiva Sai, DR. Si Khan "Smart Surveillance System Using Computer Vision", *ISSN*, Vol 6, Issue 6, pp: 941-944, June-2021
- [6]. "Machine Learning is Fun! Part 4: Modern Face Recognition with Deep Learning." [Online]. Available: [HTTPS://medium.com/@ageitgey/machine-learning-is-fun-part-4-modern-face-recognition-with-deep-learning-c3c0c121d78](https://medium.com/@ageitgey/machine-learning-is-fun-part-4-modern-face-recognition-with-deep-learning-c3c0c121d78)
- [7]. P. Hu, H. Ning, T. Qiu, Y. Xu, X. Luo, and A. K. Sangaiah, "A unified face identification and resolution scheme using cloud computing in Internet of Things," *Future Generation Computer Systems*, vol. 81, pp. 582–592, Apr. 2018.
- [8]. S. Singh and N. Singh, "Container's amp; amp; Docker: Emerging roles amp; amp; future of Cloud technology," in *2016 2nd International Conference on Applied and Theoretical Computing and Communication Technology (iCATccT)*, Jul. 2016, pp. 804–807.
- [9]. Rahul Rawat, Ratnesh Pd Srivastava, "IOT Based Surveillance System Using DNN Model", *ISSN: 2321- 9653*, Vol: 9, Issue XII, Dec -2021
- [10]. A.D Deshmukh, M.G NakaraniBhuyar, U.B. Shinde, "Face Recognition Using OpenCV Based on IoT for the smart door" *SSRN*, January -2019.
- [11]. C.Muragan, H. Balachander, M. Beston James, "Raspberry Pi Based Smart Surveillance Enhanced with Wi-Fi Technology", *IJET*, Vol 7(4.6) .2018, 559-562.
- [12]. Raksitha BM, Sandhya V, "IOT Based Real-Time Surveillance Using Raspberry Pi", *ISSN: 2349 – 4689*, 2017.
- [13]. Rohan Namdeo, Sahil Sharma, Varun Anand, "Smart automated Surveillance Using Raspberry Pi", *ISSN 2277-3878*, issue -2, July 2020

IJEAST

INTERNATIONAL JOURNAL
OF ENGINEERING APPLIED SCIENCE
AND TECHNOLOGY

ABOUT IJEAST

International Journal of Engineering Applied Science and Technology (IJEAST) is a peer-reviewed, open access journal that publishes high-quality research papers in the field of Engineering, Applied Science and Technology.

IJEAST aims to provide a platform for researchers, academicians, and professionals to share their innovative ideas, research findings, and practical experiences with the global scientific community.

FOCUS AREAS

- Engineering
- Applied Science
- Technology
- Innovation & Development
- Interdisciplinary Studies



PEER REVIEWED

All submissions are rigorously peer reviewed to ensure quality.



OPEN ACCESS

Free and unrestricted access to research for all.



GLOBAL REACH

Connecting researchers and professionals worldwide.



TIMELY PUBLICATION

We ensure a swift and efficient publication process.



For more information, visit our website

www.ijeast.com



INTERNATIONAL JOURNAL
OF ENGINEERING APPLIED SCIENCE
AND TECHNOLOGY

✉ editor@ijeast.com

🌐 www.ijeast.com

📍 India



2455-2143