



# IJEAST

INTERNATIONAL JOURNAL  
OF ENGINEERING APPLIED SCIENCE  
AND TECHNOLOGY



**VOLUME : 3    ISSUE : 03    Print / Issue Publication Date: 23-Oct-2018**



**ISSN : 2455-2143**



Indexed In



[WWW.IJEAST.COM](http://WWW.IJEAST.COM)

[editor@ijeast.com](mailto:editor@ijeast.com)

# SIMULATION AND ANALYSIS OF MPPT ALGORITHM FOR PV ARRAY USING SEPIC CONVERTER

Payal Pramanik

Department of Electrical Engineering  
 JNTU Kakinada, Kakinada, Andhra Pradesh, India

T.Murali Mohan

Department of Electrical Engineering  
 JNTU Kakinada, Kakinada, Andhra Pradesh, India

**Abstract**— In this paper a detailed analysis of Sepic Converter is put forward whose input is provided by a renewable source of energy using PV array. The input to the converter is controlled using a feed forward controller thereby ensuring that the voltage at the instant of maximum power is tracked. The PV module is subjected to variations in temperature and radiations. The controller with which maximum power point is traced makes use of several algorithms. But in this paper Perturb and Observe algorithm is used which makes the analysis faster and simpler. With the variation in temperature and radiation the power, current and voltage characteristics are also studied in this paper. The operating point goes on perturbing at MPP until it observes change in temperature or radiation and once the change occurs sudden transfer in operating point proportional to the change can be observed and again the operating point goes on perturbing at next MPP. The simulation results in MATLAB/SIMULINK shows that the Sepic Converter designed under Standard testing conditions and with variation of radiation and temperature successively is highly efficient and has fewer oscillations in the waveforms.

**Keywords**— Sepic converter, MPP technique, PV Array, temperature, radiation, controller, Standard testing conditions (STC).

## I. INTRODUCTION

Conversion of DC voltages from one level to other level is quite complex compared to AC conversion. Eldest technology used involved the usage of diodes, voltage bridges and voltage regulators which make the conversion inefficient as mentioned by (Rashid Md. H. 2014). In order to overcome all the above latest inventions in designing various DC-DC converters are made. Generally, these converters are categorised into five categories namely Buck, Boost, Buck-boost, Cuk, Sepic converters. Buck converters steps down the output voltages within wide variation of input voltage. Boost converters steps up the output voltage whereas the buck-boost performs both the operation within wide variation in input and output voltages. These converters suffer from high amount of ripple in input current thereby enhancing the growth of harmonics

which makes the above converters inefficient and expensive. Cuk converters overcome the above stated disadvantage but they impose high electrical stress on the components which can be swept by Sepic Converter.

Sepic Converter is thereby designed to efficiently produce the output voltage. In this paper the converter is supplied with input voltage delivered by PV array by varying the radiation and temperature of the PV panel. The voltage, as suggested by Banaei M. R. et al. (2014), delivered by the PV panel is sent to a controller which tracks the maximum power point and the voltage at that point is given to the converter.

The details of MSX-60 solar module is described in (Vilalva M. G., Gazoli J. R., et al., 2009). Designing of Sepic converter is discussed by (Dongbing Zhang, 2013). The rest of the paper is organized as follows. Modeling of PV array, Designing of Sepic Converter and Proposed MPPT algorithm are explained in section II. Experimental results are presented in section III. Concluding remarks are given in section IV.

## II. PROPOSED METHODOLOGY

### A. PV Array Modelling –

A solar cell, or photovoltaic cell, is an electrical device that converts the solar energy directly into electricity by the photovoltaic effect. In this paper multi-diode model is illustrated which consists of large number of series diodes as implemented by Banaei M. R., et al., (2014) and multiple numbers of parallel diodes connected in the fashion as shown below:

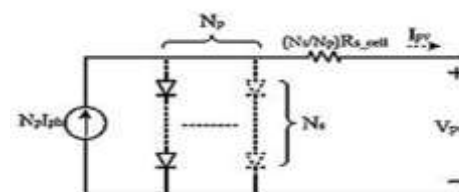

Fig. 1. Multi-diode model

$N_s$  is the number of cells connected in series and  $N_p$  is the number of cells connected in parallel.  $N_p$  amount equal to 1 and  $N_s$  are considered to be standard 36 or 72 .



The output current,  $I_{pv}$  and the terminal voltage,  $V_{pv}$ , as suggested by Banaei M. R., et al., (2014), of a photovoltaic module are henceforth dependent on two variables,  $I_{ph}$  and  $I_o$ , where  $I_{ph}$  represent photo current and  $I_o$  represents the reverse saturation current of diode.

As  $V_{pv}$ , or the terminal voltage depends upon the current dependent voltage source used, the output current of the PV module is obtained from the following equation. As established by the mathematical model,  $V_{pv}$  is used as a feedback to calculate  $I_{pv}$ . This equation is obtained by applying KCL at positive output node of the multi-diode models' equivalent circuit.

$$I_{pv} = N_p I_{ph} - N_p I_o (e^A - 1)$$

where

$$A = \frac{q(V_{pv} + R_{s\_mod} I_{pv})}{N_s AKT}$$

Where,

$I_{pv}$  is the output current

$N_p$  is the number of parallel connected branches

$I_{ph}$  is photo-current of the solar cell

$I_o$  is the reverse saturation current

$V_{pv}$  is the terminal voltage

$q$  is the charge of an electron

$R_{s\_mod}$  is series resistance

$N_s$  is the number of series connected cells in each shunt branch

$A$  is the p-n junction ideality factor and its value is tabulated in (Banaei M. R., et al., 2014)

$K$  is Boltzmann constant.

$T$  is the cell temperature in kelvin.

The primary dependency of output current,  $I_{pv}$ , is found to be with  $I_{ph}$  or photocurrent of the solar cell and  $I_o$  or the reverse saturation current, which are further obtained using the following equations

$$I_{ph} = [I_{scr\_cell} + k_i(T - T_r)] \frac{G}{G_r} \quad (1)$$

$$I_o = I_{rs} \left(\frac{T}{T_r}\right)^3 e^{-\frac{qE_g}{AK} \left(\frac{1}{T_r} - \frac{1}{T}\right)} \quad (2)$$

Where,

$I_{scr\_cell}$  is the cell short circuit current at the standard testing condition(STC).

$k_i$  is temperature coefficient of short circuit current  $I_{sc}$ .

$I_{rs}$  is the reverse saturation current of cell.

$E_g$  is band gap energy of the semiconductor and its value is demonstrated in (Banaei M. R., et al., 2014).

$T$  and  $T_r$  are the cell temperature and reference temperature.

$G$  and  $G_r$  are the incident solar radiation and reference radiation.

The standard testing conditions (STC), is referred to the conditions with the reference solar radiation ( $G$ ) of  $1000W/m^2$  and solar cell reference temperature ( $T$ ) of  $25^\circ C$ .

$$I_{scr\_cell} = I_{scr\_mod} \times \frac{1}{N_p} \quad (3)$$

where  $I_{scr\_mod}$  is the PV module short circuit current at reference temperature and radiation.

The reverse saturation current,  $I_{rs}$ , is obtained by using the following equation and is found to vary with the cell constants  $V_{oc\_mod}$  and  $I_{scr\_mod}$ , or open circuit voltage and short circuit current of the PV module at reference temperature and radiation.

$$I_{rs} = \frac{I_{scr\_mod}}{N_p (e^B - 1)} \quad (4)$$

where

$$B = \frac{qV_{oc\_mod}}{N_s AKT}$$

The complete model of photovoltaic module as discussed by Banaei M. R., et al., (2014), has the entire PV module modelled as a mathematical block with cell radiation and temperature as variables, generating equivalent solar energy in the form of  $V_{pv}$  and  $I_{pv}$  at its terminals.

The Simulink model illustrating MSX-60 PV array module is shown below.

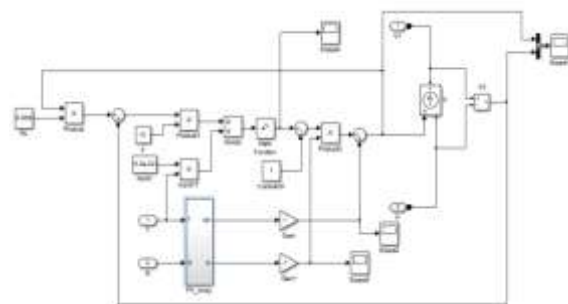

Fig. 2. Simulink block representing PV array module.

## B. Sepic Converter –

The DC-DC converter used is Sepic Converter. The purpose of this project was to design and optimize a Sepic



dc/dc converter using (Dongbing Zhang, 2013). The switching device used is MOSFET with the switching frequency of 1KHz and duty cycle can be varied from 0 to 1. The components of the Sepic Converter are discussed in the below table:

Table. 1 – Design Specifications of Sepic Converter

$C_{in}$	$L_1$	$C_1$	$L_2$	$C_2$	$R$
20 mF	2.4 mH	25 $\mu$ F	2.4 mH	2.5 mF	50 Ohms

The Sepic converter is supplied with PV array module and with a load. The open loop converter block diagram with PV module is shown in the figure below:

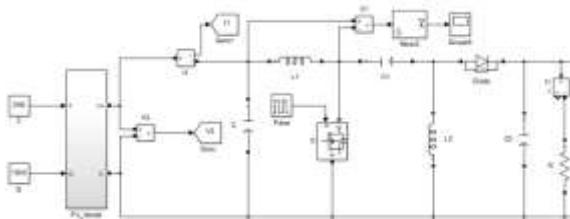

Fig. 3. Open-loop model of Sepic Converter.

The above figure is not applied with the control technique and the operation is directly controlled by varying duty cycle of the converter. The load resistance is taken as 50 ohms.

### C. MPPT Unit –

The MPPT unit discusses about the technique involved in maximum power tracking such that voltage at that instant is delivered to the conversion unit. In this stage the output is controlled through the controller such that the conversion unit delivers the output depending on the voltage delivered at maximum power point.

The algorithm used in this paper is Perturb and Observe (P&O) method. The time complexity used in this method is very less but the only limitation is as the MPP reaches it doesn't stop at MPP but it keeps on perturbing on both the directions. The paper discusses the power output of the module with variations in radiation and temperature and also the standard condition is analysed.

The Sepic Converter cascaded with PV module with MPPT block developed using Simulink is shown in the below figure.

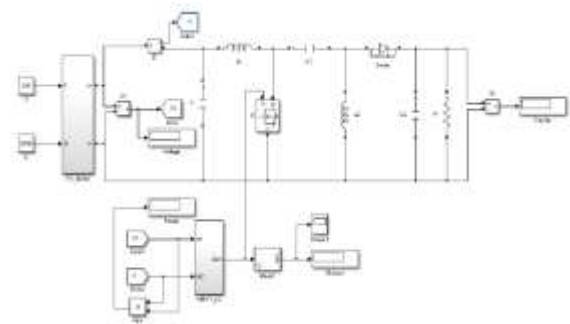

Fig. 4. MPPT control of PV module.

In order to track maximum power point the algorithm is as follows:

- 1). Read the values of voltages and power at an instant.
- 2). Calculate change in power and voltages.
- 3). Check if change in power is equal to zero and if it is zero then duty cycle remains unchanged.
- 4). Check if change in power is positive and change in power is also positive if it remains positive then decrease the duty cycle or else increase it.
- 5). Check if change in power is positive and change in power is negative in such a case increase the duty cycle. Similarly check for opposite case and decrement the duty cycle.

The table below illustrates the change in power and voltage corresponding changes in duty ratio.

Table. 2 – Changes in power and voltages

dP	dV	Duty cycle(D)
Positive	Positive	Decreased
Positive	Negative	Increased
Negative	Positive	Decreased
Negative	Negative	Increased

## II. EXPERIMENT AND RESULT

### A. PV Array Output Characteristics-

The figure below shows P-V characteristics of PV module at STC and the maximum power point at which the operating point is going on perturbing.

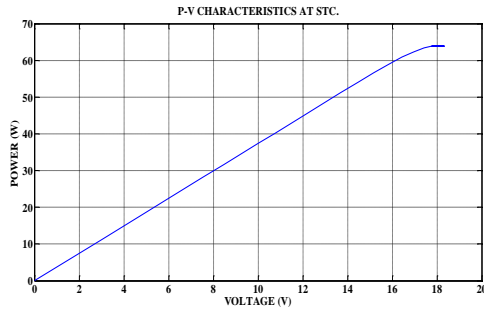

Fig. 5. Maximum power point perturbing at STC

The figure below illustrates the changes in current and voltage at STC

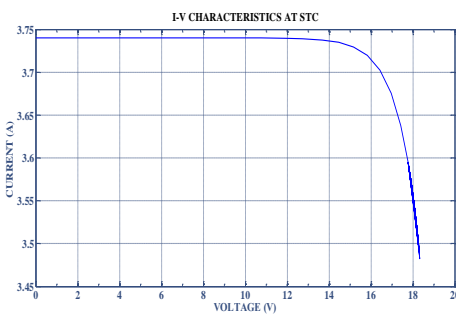

Fig. 6. I-V characteristics at STC

The figure illustrates P-V characteristics for variable G and fixed T. From the below curve the top most dotted line (pink) refers  $G=1200\text{W/m}^2$ , the next dotted line (red) refers at  $G=1000\text{W/m}^2$ , the second bottom one (brown) refers at  $G=800\text{W/m}^2$  and the bottom line (blue line) refers at  $G=600\text{W/m}^2$ .

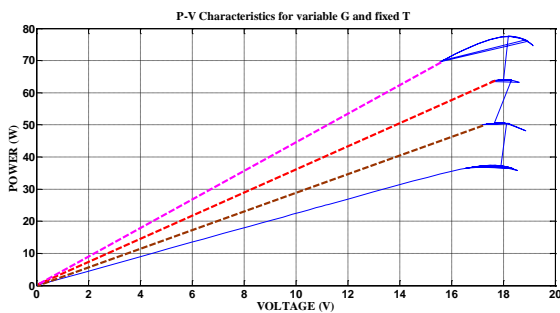

Fig. 7. P-V characteristics for variable G and fixed T

The figure illustrates P-V characteristics for variable G and fixed T.

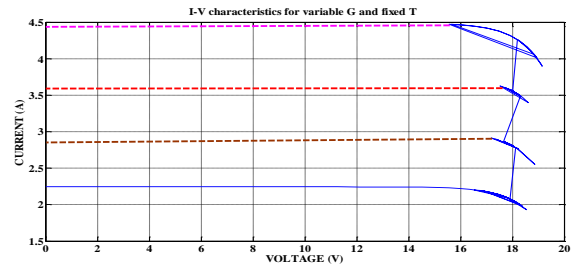

Fig. 8. I-V characteristics for variable G and fixed T

From the above P-V and I-V curve it can be seen that the operating point is shifting whenever change in radiation is being detected. Also the limitation of using P&O algorithm is portrayed in the above figure i.e; upon reaching MPP at particular radiation the operating point doesn't stop at MPP but it goes on perturbing at that point until it experiences alteration in the radiation and once it senses the change ,rapid variation in the operating point corresponding to that change can be observed.

### B. Variation of Output Voltage, Output Power, Input Power and Input Voltage Using MPPT-

The figure below illustrates output and input power variation at STC.

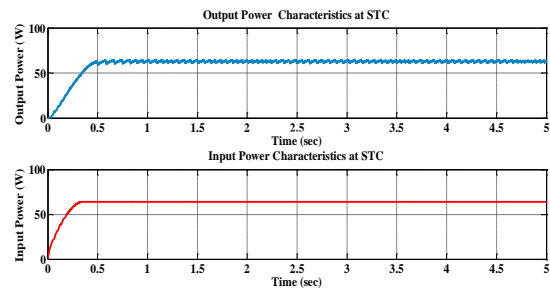

Fig. 9. Output and Input Power variations at STC

The figure below illustrates output and input voltages variation at STC.

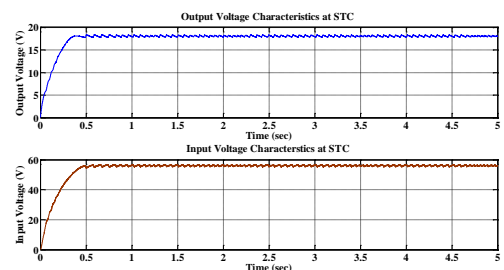

Fig. 10. Input and Output Voltage variations at STC

The figure below illustrates the variation of input and output powers for variable T and fixed G. Variations in T are as follows 290K, 298K, 310K, 330K. The variation in



temperature with respect to time is given by Banaei M. R., et al., (2014).

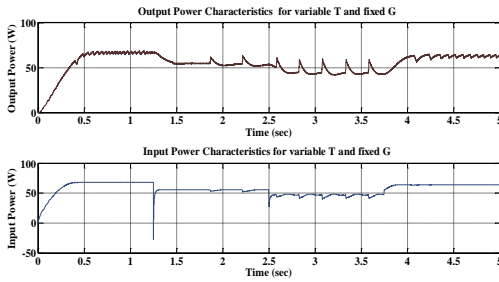

Fig. 11. Variation of Powers for fixed G and adjustable T.

The figure below illustrates the variation of input and output voltage for variable T and fixed G. Variations in T are as follows 290K, 298K, 310K, 330K. The variation in temperature with respect to time is given by Banaei M. R., et al., (2014).

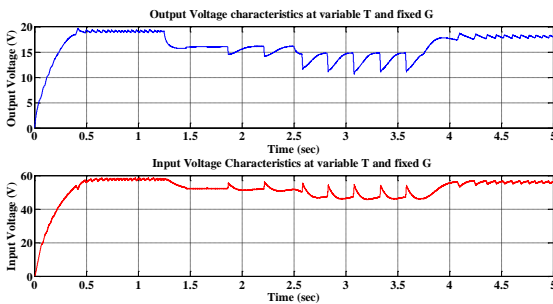

Fig. 12. Variation of Voltages for fixed G and adjustable T.

The figure below illustrates the variation of input and output power for variable G and fixed T. Variations in G are 600, 800, 1000, 1200 W/m<sup>2</sup> respectively. The variation in radiation with respect to time is given by Banaei M. R., et al., (2014).

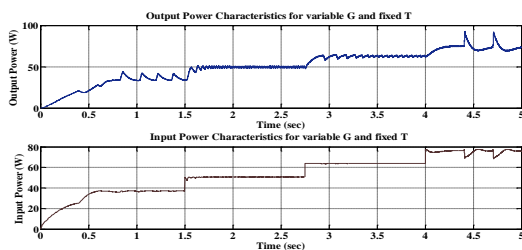

Fig. 13. Variation of Powers for fixed T and adjustable G

The figure below illustrates the variation of input and output voltages for variable G and fixed T. Variations in G are 600, 800, 1000, 1200 W/m<sup>2</sup> respectively. The variation in radiation with respect to time is given by Banaei M. R., et al., (2014).

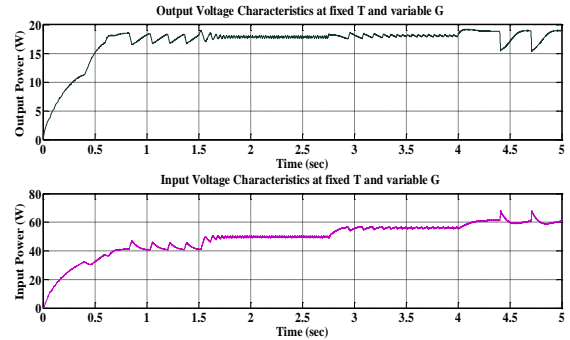

Fig. 14. Variation of Voltages for fixed T and adjustable G

The maximum power points for variable inputs are shown in the table below:

Table 3 – Input voltage and power variations for different values of G and T

S.No	G (W/m <sup>2</sup> )	T (K)	Input Voltage (V)	Input Power (W)
1	1000	298	18.04	64.02
2	1000	290	19.05	68
3	1000	315	16.03	55.62
4	1000	330	14.17	48.3
5	600	298	17.85	37.36
6	800	298	17.74	50.6
7	1200	298	18.23	77.55

#### IV.CONCLUSION

A Sepic Converter is designed and analysed using PV array module which is simultaneously being controlled by MPPT controller. The variation in output voltages, current and power of PV-array module for STC and even for the variations in temperature and radiation are tabulated. The output voltage of the converter is studied for the input being supplied by the PV-array at maximum power point. The efficiency of the Sepic Converter is even realised. The extension in this area of research can be prolonged by designing a High frequency resonant Sepic Converter and analysing it under the same conditions and comparing the results in both the cases.

#### V. ACKNOWLEDGEMENT

I gratefully thank the faculty of Electrical Engineering for their relentless efforts in materializing the project and also the non-teaching staff for their guidance and support throughout the project.

#### VI. REFERENCE



- [1] Villalva M. G., Gazoli J. R. and Filho E. R., (2009). Comprehensive approach to modeling and simulation of photovoltaic arrays, in *IEEE Trans. PowerElectron*, Vol. 24, No. 5, (Pg1198–1208).
- [2] Banaei M. R., et al., (January 2014), MPPT control of Photovoltaic using SEPIC converter to reduce the input current ripples, in *Int. Journal of Engineering Research and Applications* ISSN: 2248-9622, Vol. 4, Issue 1, Version 2, (pp.160-166).
- [3] Dongbing Zhang, (2013), AN-1484 Designing A SEPIC Converter.
- [4] Anurag Rai, Bhoomika Awasthi, Shweta Singh, Dwivedi C. K., (June 2016), A Review of Maximum Power Point Tracking Techniques for Photovoltaic System, *International Journal of Engineering Research*.
- [5] Walker G., (2001), Evaluating MPPT converter topologies using a matlab PV model, *J. Elect. Electron. Eng.*, Vol. 21, (Pg45–55).
- [6] Morales D., (2010), *Maximum Power Point Tracking Algorithm for photovoltaic Applications*, Thesis for the Degree of Master of Science, Aalto University, Finland
- [7] Rashid Md. H., (2014), *Power Electronics handbook*, Pearson Education Ltd., 4<sup>th</sup> Edition.
- [8] Parameshwara Reddy B., Saravanan S., (2013), Analysis and Design of High Frequency Resonant SEPIC Converter, *International Journal of Power Control and Computation (IJPCSC)*, Vol5. No.2, (pp. 42-46).
- [9] Ganesh S., Janani J., Besliya Angel G., (2014), A Maximum Power Point Tracker for PV Panels Using SEPIC Converter.
- [10] Linu Ann Thomas, Merin Abraham, Jerin M James, (April 2016), MPPT Technique Using SEPIC Converter to track Maximum Power Point for PV Panel
- [11] Singh K., Tiwari A. N. and Singh K. P., (2012), Performance Analysis of Modified SEPIC Converter with Low Input Voltage, *IJECT*, Vol.3, ISSUE1,ISSN: 2230-7109.

# IJEAST

INTERNATIONAL JOURNAL  
OF ENGINEERING APPLIED SCIENCE  
AND TECHNOLOGY

## ABOUT IJEAST

International Journal of Engineering Applied Science and Technology (IJEAST) is a peer-reviewed, open access journal that publishes high-quality research papers in the field of Engineering, Applied Science and Technology.

IJEAST aims to provide a platform for researchers, academicians, and professionals to share their innovative ideas, research findings, and practical experiences with the global scientific community.

## FOCUS AREAS

- Engineering
- Applied Science
- Technology
- Innovation & Development
- Interdisciplinary Studies



### PEER REVIEWED

All submissions are rigorously peer reviewed to ensure quality.



### OPEN ACCESS

Free and unrestricted access to research for all.



### GLOBAL REACH

Connecting researchers and professionals worldwide.



### TIMELY PUBLICATION

We ensure a swift and efficient publication process.



For more information, visit our website  
[www.ijeast.com](http://www.ijeast.com)



INTERNATIONAL JOURNAL  
OF ENGINEERING APPLIED SCIENCE  
AND TECHNOLOGY

✉ [editor@ijeast.com](mailto:editor@ijeast.com)

🌐 [www.ijeast.com](http://www.ijeast.com)

📍 India



2455-2143