



# IJEAST

INTERNATIONAL JOURNAL  
OF ENGINEERING APPLIED SCIENCE  
AND TECHNOLOGY



**VOLUME : 5    ISSUE : 10    Print / Issue Publication Date: 25-Apr-2021**



**ISSN : 2455-2143**



**DOI : 10.33564/IJEAST.2021.v05i10.042**

Indexed In



[WWW.IJEAST.COM](http://WWW.IJEAST.COM)

[editor@ijeast.com](mailto:editor@ijeast.com)

# EXPERIMENTAL INVESTIGATION OF ENHANCEMENT IN EFFICIENCY OF CENTRIFUGAL PUMP BY REDUCTION IN CAVITATION OF PUMP

Gaffar G. Momin

Assistant Professor in Mechanical Engineering

Dept. Of Mechanical Engineering,

Pimpri Chinchwad College of Engineering, Nigdi, Pune-44, M.S.(India)

**Abstract**— Cavitation phenomenon is basically a process formation of bubbles of a flowing liquid in a region where the pressure of the liquid falls below its vapour pressure and it is the most challenging fluid flow abnormalities leading to detrimental effects on both the centrifugal pump discharge characteristics as well as physical characteristics. In this low pressure zones are the first victims of cavitation. Due to cavitation pitting of impeller occurs and wear of internal walls of pumps occurs due to which there is creation of vibrations and noise are there. Due to this there is bad performance of centrifugal pump is there. Firstly, description of the centrifugal pump with its various parts are described after that pump characteristics and its important parameters are presented and discussed.

Passive discharge (flow rate) control methods are utilized for improvement of flow rate and mechanical and volumetric and overall efficiency of the pump.

Mechanical engineers is considering an important phenomenon which is known as Cavitation due to which there is decrease in centrifugal pump performance. There is also effect on head of the pump which is getting reduced due to cavitation phenomenon. In present experimental investigation the cavitation phenomenon is studied by starting and running the pump at various discharges and cavitating conditions of the centrifugal pump. Passive discharge (flow rate) control is realized using three different impeller blade leading edge angles namely 9.5 degrees, 16.5 degrees .and 22.5 degrees for reduction in the cavitation and increase the of the centrifugal pump performance at different applications namely, domestic, industrial applications of the centrifugal pump.

**Keywords:** Centrifugal pump, Efficiency enhancement of centrifugal pump by minimization of cavitation phenomenon of the Centrifugal pump.

## I. INTRODUCTION

### 1.1. Centrifugal pumps

The Centrifugal pump, or any type of pump, is utilized for displacement of water It is mainly composed of two important parts which are: 1) Impeller and 2) Spiral or volute casing. 3) Suction pipe 4) Delivery (discharge) pipe 5) Discharge head. The fluid is entering in the pump from eye side of impeller and coming radially from the impeller. The momentum of the fluid is increased while passing through the rotating impeller blades of the pump until it reaching at the outlet side of the impeller, the acquired fluid high velocity is converted to a pressure increase enough to overcome the required Head. The impeller blades rotating motion, continuously creates the vacuum at the impeller eye, which then results in a continuous suction of the fluid from the inlet pipe towards the impeller eye. That means centrifugal pumps are responsible to convert mechanical energy into pressure energy. That means conversion of mechanical energy to hydraulic energy.

### 1.2 Cavitation in pumps

Cavitation is a phenomenon in which the reduction of *pressure* to or below the fluid *vapour pressure* leads to the formation of small cavities in the fluid. When these cavities are subjected to high pressure bubble formation and eddies are occurred. Due to that damage of pump parts would be there.

Due to different losses within the pump or outside during the energy transfer process, such as disc friction, shock losses, mixing, change in direction of fluid, separation, bearing losses, turbulence, and leakage losses, the fluid-acquired hydraulic energy (water horsepower) is always smaller than the shaft transmitted energy (Brake horsepower).

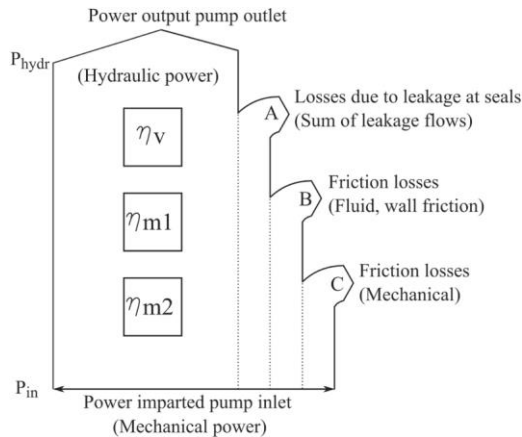

Fig.1 Block diagram showing different losses.

## II. LITERATURE REVIEW

Various researcher scholars have considerably contributed in studying the cavitation phenomenon in centrifugal pumps, applying passive discharge (flow control) control techniques and realization a couple of experiments. Opposite to that, there is very limited number of works has been carried out regarding the effect of the blade leading edge angle on the pump cavitation. Hirschi et al. presented the results obtained with a 3D numerical method allowing the prediction of the cavitation nature or of a centrifugal pump and compared this prediction to model tests. Hofmann et al. studied the cavitation by experimental investigation of two centrifugal pumps that are having different runner geometries as well as different leading edge angles within the same runner.

Siljegovic et al. concluded that passive flow control can effectively modulate flow conditions in a capillary driven microfluidic device. Ulas designed and studied experimentally two cavitating venturis to deliver the desired mass flow rates for specific conditions. Escaler et al. carried out an experimental investigation in order to evaluate the detection of cavitation phenomenon in actual hydraulic reaction turbines. Japikse et al. carried out a series of tests and improved the stability of compressors and hydraulic pumps using passive flow control technique. Luo et al. studied has done experimental investigation of the effect of inlet geometry of impeller on performance improvement for a centrifugal pump. Wu et al. carried out an experimental investigation in order to measure the cavitation phenomenon of a centrifugal pump and its effect on hydrodynamic performance. Kyparissis and Margaris studied experimentally as well as computationally a centrifugal pump with double-arc synthetic blade design method in cavitating as well as non cavitating conditions. He has applied different rotational speed of the impeller.

The present experimental study and passive discharge (flow) control are concerned with the effect of the blade leading edge angle on the cavitation phenomenon of a centrifugal pump applying the double-arc synthetic blade design method with rotational speed of 1250 rpm and flow

rate of 35 m<sup>3</sup>/h. The experimental investigations are done in a pump test rig which was specially designed and constructed, along with the closed type of impellers. The test rig allows optical observation of the fluid flow field as well as cavitation with the aid of the stroboscopic light source. The head drop and total efficiency curves are presented in order to do investigation the effect of the blade leading edge angle of impeller on the cavitation and performance of the pump. In addition to that, the vapour pressure distribution along with the impeller blades is interpreted for the different blade leading edge angles.

## III. EXPERIMENTAL TEST RIG

The experimental study was performed using the pump test rig with instrumentation system is represented in Figure 2.1. and the complete experimental setup without instrumentation. In that following components are visible. These are discussed as follows. 1. Centrifugal pump coupled with 0.75 HP motor 2. Suction pipe manufacture from M.S. material 3. Delivery pipe manufacture from M.S. material 4. Burdon type vacuum Gauge 5. Burdon Pressure Gauge 6. Water Reservoir (water tank) 7. Electro-magnetic flow meter, etc. Moreover, the flow rate (discharge in LPH) regulation was obtained by installed at the discharge pipe. The differential pressure between the pump inlet and outlet is measured by the differential pressure digital meter (9) The pump was driven by a single-phase AC electric motor of 0.75 HP and maximum rotational speed of 1440 rpm. Important parts of the pump test rig allow observation of fluid flow inside the impeller and photography of the development of cavitation in flow passage of the impeller. The measurement data were acquired by the data acquisition system as represented in figure 2.1.



**FIGURE 2.1 : The complete experimental setup along with the instrumentation system.**



**FIGURE 2.2 : The complete experimental setup without instrumentation.**

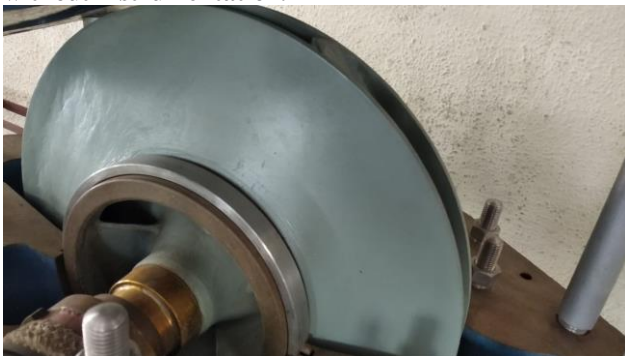

**Fig.a)**

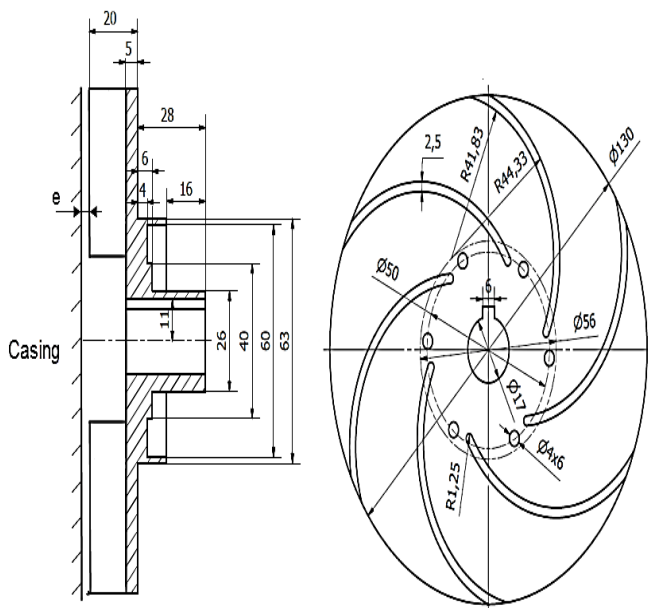

**Fig.b)**

**Figure 3: The observed geometry of impeller and with blade leading edge angle of 9.5 deg.**

Moreover, during every measurement, the cavitation is illustrated using the stroboscopic light. The NPSH value that the first bubble appears, according to the visualization of cavitation, is the net positive suction head required NPSHr.

The measuring equipment consists of an absolute and a differential pressure transducer, a temperature sensor, and an electromagnetic flowmeter. In order to measure the static pressure at the suction side of the pump, an absolute pressure transducer from ABB 2800T series, model 274NS with a base accuracy  $\pm 0.070\%$  is applied. Moreover, the pressure difference between the discharge and suction region of the pump is measured using a differential pressure transducer from ABB 2800 T series, model 274 DS with a base accuracy  $\pm 0.070\%$ . In addition, temperature is measured with the temperature sensor of the ABB SensyTemp TSP2200 series. Furthermore, the measurement of the flow rate is realized using an electromagnetic flowmeter ABC FXE5000, model DE44F with a base accuracy  $\pm 0.55\%$ .

The rotational speed of the three phase electric motor can be continuously varied by the inverter Fuji Electric FVR-E8S series. The study of cavitation is realized using the vacuum pump series LABOPORT M 818.3 KN.47.18. Series N 816.3 diaphragm pumps are double-head, dry-running devices used in a wide range of laboratory applications. They transfer and pump down without contamination.

The measurement data from the pressure transducers, flowmeter, and temperature sensor are acquired by the analog input module CFP-AI-210. The National Instruments CFP-AI-210 is an 8-channel single-ended input module for direct measurement of millivolt, low voltage, or milliampere current signals from a variety of sensors and transmitters. It delivers filtered low-noise analog inputs with 16-bit resolution and 5 S/s sampling rate. Finally, this analog input module is connected to lab

#### IV. BLADE DESIGN ANALYSIS

**4.1. Impeller Geometry.** Three impeller geometries have been constructed using aluminium alloy 7075-T6, which is composed of zinc as the primary alloying element. It is strong, with strength comparable to many steels and has

**TABLE 1: Main characteristics of the tested pump impellers.**

**Pump Impeller Parameters :**

Sr.No.	Pump Parameter	Diameter	SI Unit
1	Pipe Diameter of Suction	$D_s$	Mm
2	Impeller Diameter of the at the suction side	$D_1$	Mm

3	Impeller Diameter of the at the Delivery side	$D_2$	mm	The impellers have been designed according to the dimensions volute dimensions, which is installed in the pump test rig represented in fig.2.1 and 2.2. The main characteristics of the three tested impellers are presented in Table 1.  4.2. Double-Arc Synthetic Method: DASM. In the present work, the double-arc synthetic method was applied for the impellers blade design of the centrifugal pump. It is a simple design method. There are published computational studies that compare double-arc synthetic method (DASM with the P-fleiderer centrifugal pump analysis methods and it is found that a centrifugal pump which I have tested has better efficiency applying double-arc synthetic method.  As shown in Figure 6, the auxiliary circle $C_a$ is drawn, according to the following formula:
4	Width of Impeller at the suction side	$b_1$	mm	
5	Width Impeller at the Delivery side	$b_2$	mm	
6	Blade leading edge angle at the suction side.	$\beta_1$	deg	
7	Blade trailing edge angle at the Delivery side	$\beta_2$	deg	
8	Maximum Impeller blade thickness	$S$	mm	
9	Number of blades on Pump Impeller	$z$	Number	

good fatigue strength and average machinability, but has less resistance to corrosion than many other aluminium alloys. 7075-T6 is a heat temper grade of aluminium alloy 7075. It has an ultimate tensile strength of 520–548 MPa and yield strength of at least 437–482 MPa. In addition, the tested impellers have a removable transparent cover disk made of plexiglas in order to observe the fluid flow and the cavitation, as shown in Figures 3, 4, and 5.

As shown in Figure 6, the auxiliary circle  $C_a$  is drawn, according to the following formula:

$$d_1 = D_1 \sin \beta_1,$$

where  $D_1$  is the diameter of the impeller at the suction side and  $\beta_1$  is the blade leading edge angle.



Fig.a



Fig.a

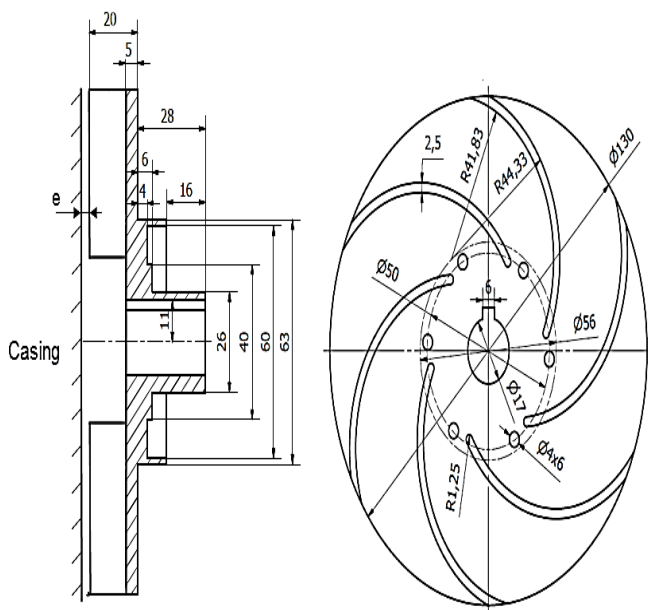

Fig.b

Figure 4: The observed geometry of impeller and with blade leading edge angle of 16.5 deg.

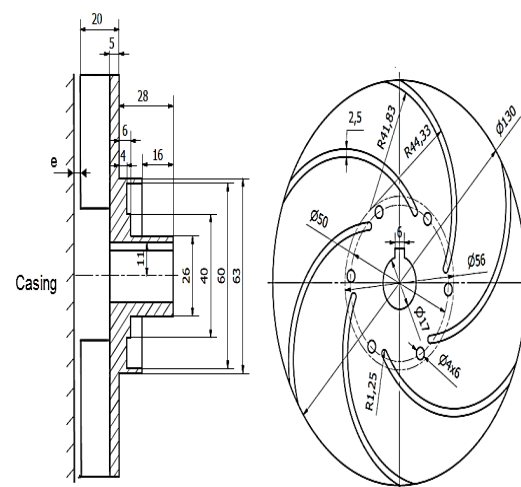

Fig.b

Figure 5: The observed geometry of impeller and with blade leading edge angle of 22.5 deg.

## V. EXPERIMENTAL RESULTS

In the present study, the experimental investigation and passive flow control are realized in order to examine the centrifugal pump performance and cavitation development for three different impeller blade leading edge angles. Studying the non cavitating performance, the total head and the total efficiency as functions of the flow rate (discharge in LPH) are represented in Figures 7 and 8 respectively. For the three examined blade leading edge angles and rotational speed of 1440 rpm. As represented in Figure 8, the flow rate (Discharge in m<sup>3</sup>/h to the best efficiency point is approximately 24.5 m<sup>3</sup>/h for 9.5 deg, 36.5 m<sup>3</sup>/h for 16.5 deg, and 47.5 m<sup>3</sup>/h for 22.5 deg.

The total head drops for the rotational speed of 1440 rpm, flow rate of 36.5 m<sup>3</sup>/h, and three examined blade leading edge angles of 9.5, 16.5, and 22.5 deg were represented. The ordinate was the total head of the pump, while the abscissa is the net positive suction head available. The filled points represent the experimental cases, where cavitation was developed. It was noticed that as the actual net positive suction head of the decreases the total head of the tested centrifugal pump also decreases slowly for all the impeller blade leading edge angles. As the water in the suction pipe approaches the impeller eye, it has velocity and acceleration. In addition, it has to change its direction to enter the impeller, because of the blade leading edge angle. Losses in terms of total head occur due to each of the above reasons and because of friction. For the blade leading edge angle of 16.5 deg, no cavitation was found, for the observed pressures at the pump inlet. Nevertheless, there is head drop as the NPSHa decreases, due to formation of cavitation bubbles, these bubbles we cannot observe using stroboscope light. Due to the bubbles there is blockage of the flow passage between the blades and it causes the head drop. Examining the blade leading edge angle of 9.5 deg, Cavitation starts to be developed for the net positive suction head of 6.16 m, which is the corresponding NPSHr for 9.5 deg. In addition, testing the 22.5 deg, the cavitation begins for NPSH = 2.4 m, which is the corresponding NPSHr for 22.5 deg.

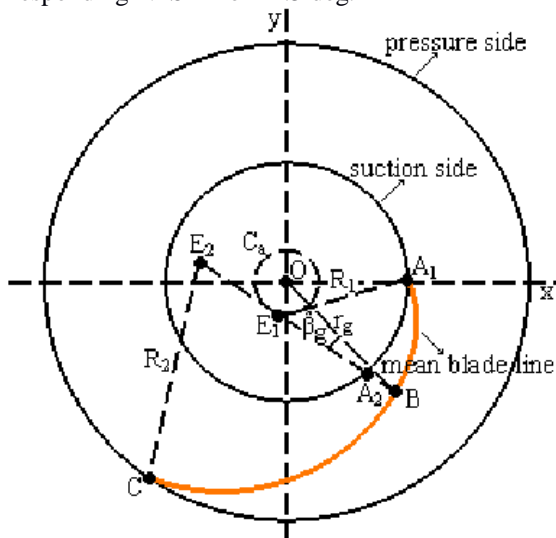

**Figure 6: Representation of the mean blade line using Double Arc Synthetic Method**

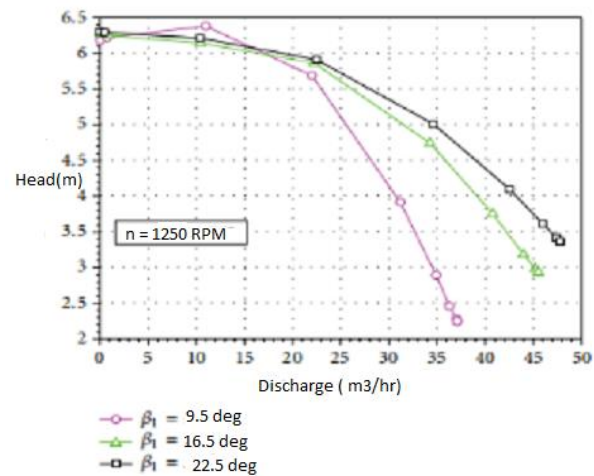

**Figure 7: The graph of total head as verses flow rate (discharge) , studying the non cavitating performance.**

Blade leading edge angles are 13.32%, 4.46%, and 6.80%, respectively. For the blade leading edge angles 9.5 and 22.5 deg, when cavitation starts to be developed the corresponding head drops were 5.48% and 5.50 %, respectively. Thus, it is observed that for both the cases that cavitation begins, the total head is reduced by 5.5% instead of 3% that is defined by Hydraulic Research Centre (Hydraulic Institute). The NPSHr can be from 2 to 20 times the 3% that the Hydraulic Research Centre (Hydraulic Institute) defines, depending on pump design . The cavity length when the cavitation bubbles appear is measured 4.1 and 7.2 mm for 9.5 and 22.5 deg, respectively. It is observed that as leading blade angle increases Head also increases. Finally, as the NPSH (Net Positive Suction Head available (NPSHA) decreases the pump flow rate (discharge) in the tested centrifugal pump was kept almost constant, in the development of pump cavitation phenomenon.

Last but not least, for the lowest examined value of the NPSH (Net Positive Suction Head available (NPSHA) the total head has the lowest values for all the examined blade leading edge angles, because as the net positive suction head decreases the total head of the centrifugal pump also decreases, as represented in Figure 8.

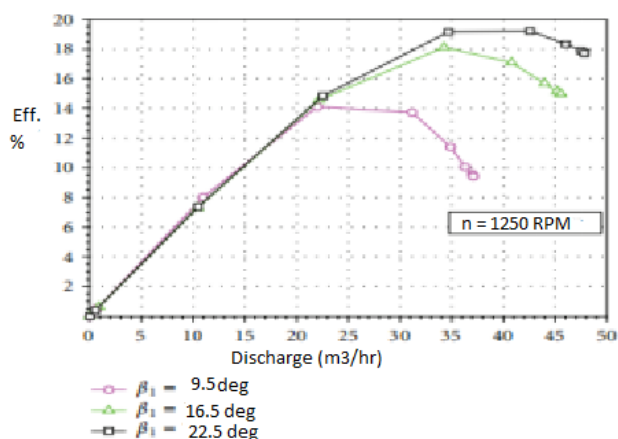

**Figure 8: The graph of efficiency verses flow rate (discharge) , studying the non Cavitation performance.**

## VI. CONCLUSIONS

The present experimental study and passive flow control are concerned with the effect of the blade leading edge angle on the cavitation phenomenon and performance of a centrifugal pump. A pump test rig has been developed in order to realize a passive flow control with different blade leading edge angles.

The rotational speed of 1440 rpm and flow rate of 35 m<sup>3</sup>/h are applied. Studying the effect of the blade leading edge angle on the cavitation phenomenon, it is observed that as the blade leading edge angle increases, there is enhancement in both head and Mechanical efficiency of the Centrifugal pump represented in fig.2.1 and 2.2, at examined operating conditions. Moreover, it is observed that as the NPSH (Net Positive Suction Head (NPSH) the total head decreases very slowly for all the blade leading edge angles namely 9.5 deg, 16.6 deg and 22.5 deg.

## VII. RESULTS AND DISCUSSION

I observed that for leading edge angle of 9.5 deg. the cavitation was developed in the region of pressure side.

But, for 22.5 deg angle the cavitation is developed at the suction side of the pump. Lastly, for leading edge angle of 16.5 degrees, it was found that there was no creation of cavitation phenomenon. So it was assumed to be the suitable leading edge angle because when we use impeller with leading edge angle of 16.5 deg. there was reduction in erosion of impeller of the pump and internal side of casing of the centrifugal pump. So we can totally avoid the danger of damage of pump by using impeller angle equal to 16.5 deg. Hence due to this angle maintenance cost of the pump is also decreases.

Thus overall conclusion was that leading edge angle impeller 16.5 deg. is the best angle and we always select this angle and test the centrifugal pump should be done by using impeller leading edge angle of 16.5 deg.

## VIII. CONCLUSIVE REMARKS AND FUTURE SCOPE

In further research studies we can plan experimental investigation of Centrifugal pump by taking leading edge angle of the impeller (closed type of impeller) in between 15 degrees to 20 degrees. Also use different design methods for pump impellers for reduction in pump cavitation phenomenon. Also arrange for trial of the centrifugal pump under different Geometrical Characteristics of pump impellers and different operating conditions (at different flow rates as well as heads) by openings of delivery valve.

## IX. REFERENCES

- [1] R. Hirschi, P. Dupont, F. Avellan, J. N. Favre, J. F. Guelich, and E. Parkinson, "Centrifugal pump performance drop due to leading edge cavitation: numerical predictions compared with model tests," *Journal of Fluids Engineering*, vol. 120, no. 4, pp. 705–711, 1998.
- [2] M. Hofmann, B. Stoffel, J. Friedrichs, and G. Kosyna, "Similarities and geometrical effects on rotating cavitation in two scaled centrifugal pumps," in *Proceedings of the 4th International Symposium on Cavitation (CAV '01)*, pp. 20–23, California Institute of Technology, Pasadena, Calif, USA, June 2001.
- [3] V. Siljegovic, N. Milicevic, and P. Griss, "Passive, pro-grammable flow control in capillary force driven microfluidic networks," in *Proceedings of the 13th International Confer-ence on Solid-State Sensors and Actuators and Microsystems (TRANSDUCERS '05)*, pp. 1565–1568, Seoul, Korea, June 2005.
- [4] X. Escaler, E. Egusquiza, M. Farhat, F. Avellan, and M. Coussirat, "Detection of cavitation in hydraulic turbines," *Mechanical Systems and Signal Processing*, vol. 20, no. 4, pp. 983–1007, 2006.
- [5] X. Luo, Y. Zhang, J. Peng, H. Xu, and W. Yu, "Impeller inlet geometry effect on performance improvement for centrifugal pumps," *Journal of Mechanical Science and Technology*, vol. 22, no. 10, pp. 1971–1976, 2008.
- [6] D. Wu, L. Wang, Z. Hao, Z. Li, and Z. Bao, "Experimental study on hydrodynamic performance of a cavitating centrifugal pump during transient operation," *Journal of Mechanical Science and Technology*, vol. 24, no. 2, pp. 575–582, 2010.
- [7] S. D. Kyparissis and D. P. Margaritis, "Experimental study in a centrifugal pump with double-arc synthetic blade design method in cavitating and non-cavitating conditions," in *Proceedings of the 4th International Conference on Experiments / Process / System Modeling*



/ *Simulation / Optimization, (IC-EpsMsO '11)*, Athens, Greece, July 2011.

[8] S. D. Kyparissis and D. P. Margaritis, "Experimental investigation of cavitation in a centrifugal pump with double-arc synthetic blade design method," *International Review of Mechanical Engineering*, vol. 5, no. 5, pp. 884–892, 2011.

[9] B. Gao, X. Sun, M. Yang, and N. Zhang, "Characteristics of unsteady excitation induced by cavitating flow in centrifugal pumps," *Journal of Mechanical Engineering*, vol. 50, no. 16, pp. 199–205, 2014.

# IJEAST

INTERNATIONAL JOURNAL  
OF ENGINEERING APPLIED SCIENCE  
AND TECHNOLOGY

## ABOUT IJEAST

International Journal of Engineering Applied Science and Technology (IJEAST) is a peer-reviewed, open access journal that publishes high-quality research papers in the field of Engineering, Applied Science and Technology.

IJEAST aims to provide a platform for researchers, academicians, and professionals to share their innovative ideas, research findings, and practical experiences with the global scientific community.

## FOCUS AREAS

- Engineering
- Applied Science
- Technology
- Innovation & Development
- Interdisciplinary Studies



### PEER REVIEWED

All submissions are rigorously peer reviewed to ensure quality.



### OPEN ACCESS

Free and unrestricted access to research for all.



### GLOBAL REACH

Connecting researchers and professionals worldwide.



### TIMELY PUBLICATION

We ensure a swift and efficient publication process.



For more information, visit our website

[www.ijeast.com](http://www.ijeast.com)



INTERNATIONAL JOURNAL  
OF ENGINEERING APPLIED SCIENCE  
AND TECHNOLOGY

✉ [editor@ijeast.com](mailto:editor@ijeast.com)

🌐 [www.ijeast.com](http://www.ijeast.com)

📍 India



2455-2143