



# IJEAST

INTERNATIONAL JOURNAL  
OF ENGINEERING APPLIED SCIENCE  
AND TECHNOLOGY



**VOLUME : 6    ISSUE : 12    Print / Issue Publication Date: 03-Jun-2022**



**ISSN : 2455-2143**



**DOI : 10.33564/IJEAST.2022.v06i12.045**

Indexed In



[WWW.IJEAST.COM](http://WWW.IJEAST.COM)

[editor@ijeast.com](mailto:editor@ijeast.com)



# “DESIGN AND DEVELOPMENT OF CHASSIS OF ELECTRICAL VEHICLE”

Tejas Kale, Omkar Khalade, AyushShirke and Shrikant Pansare

**Abstract:** A new design for the chassis for a electrical vehicle in aspects of ergonomics, safety, ease of manufacture, and reliability are incorporated into the design specifications. The analysis is conducted on all major components to optimize strength and rigidity, improve vehicle components, and reduce complexity and manufacturing costs. The design is modelled considering to use it for a hybrid (solar-powered) electric vehicle. 3D models have been made for analysis purposes by using Solid works software and analysis has been made. 3D assembly models of vehicles are designed for understanding purposes.

## I. INTRODUCTION

The automotive chassis is tasked with holding all the components together while driving, and transferring vertical and lateral loads, caused by accelerations, on the chassis through the suspension and two the wheels. Chassis is a major component of a vehicle system. It consists of an internal framework that supports man-made objects. It is the under part of the vehicle which consists of frame and running gear like engine, transmission system, suspension system, etc. The automotive chassis is tasked with keeping all components together while driving and transferring vertical and lateral loads, caused by acceleration, on the chassis through suspension and the wheels.

The key to good chassis design is that the further, the mass is away from the neutral axis the more rigid it is. In this project, Solid works is the software used for the modeling of the chassis. It is an advanced CAD/CAM/CAE software.

The design and analysis of the chassis are done by identifying the location of high-stress areas. The chassis design used in this project is the ladder frame chassis. Ladder frame chassis is the simplest and oldest of the chassis design used in modern vehicular construction. It is originally adapted from horse and buggy style carriages.

A ladder frame provides sufficient strength for holding the weight of the components. The ladder frame has several members that cross-link to hold frame rails together. A simple design of rails connected by a simple span and simulated provides a very good indication of how a ladder frame is useful in regards to performance auto design.

The reason for the ladder frame type of chassis is that here it is easier to change the design without having to change the chassis there by saving overall design time. It also provides a good beam resistance because of its continuous rail from

front to rear.

## Problem Statement

- 1) The chassis frame forms the backbone of the vehicle and its chief function is to safely carry the maximum load where ever the operation demands. When the vehicle moves along the road, it must absorb engine and axle torque and absorb shock loads over twisting, pounding, and uneven road beds.
- 2) The chassis is categorized under the ladder frame type chassis for this project. A ladder frame can be considered structurally as grillages.
- 3) There are some advantages and disadvantages when using ladder frame chassis. One of the advantages is the ease of mounting and dismounting the body structure. Various body types ranging from flat platforms, box vans, and tankers to detachable containers can be adapted easily to a standard ladder frame chassis.
- 4) Besides that, the noise generated by drive train components is isolated from the passenger compartment through the use of a rubber chassis design which yields a relatively inexpensive and easy manufacturing process compared to another type of chassis.
- 5) Current design had draw backs, that is the front overhang of the chassis frame was weak so a new chassis frame was modeled by changing the dimensions and geometry.

## Objectives

- 1) The objectives of this study are:
- 2) To study the chassis design.
- 3) To develop a new campus drive vehicle chassis.
- 4) Analyze the design of chassis using the Solid works and Ansys software.
- 5) To improve the static and dynamic behavior of the chassis by
- 6) Changing the geometrical dimension and structural properties.

## Methodology

Preliminary study

Literature study, visual inspection, and measurement.

Structure setup and measurement.

Study on Solid -works and Ansys software.



Correlation between 4 sester and 6sester updating process.  
Virtual structure, design modification.  
Development of New design of EV chassis.  
Further modification if required.

## II. LITERATURE REVIEW

1.Rohan Y. Garud, Shahid C Tamboli [ISSN 0973-4562 Volume13; 2018]

“Structural analysis of automotive chassis, design modification, and optimization”

From the optimization carried out of the chassis, it can be concluded that an advanced high strength steel chassis shows a better result as compared to the original thick steel chassis. Also from the weight reduction point of view, a change in geometry topology was carried out by changing the box section to the T section from cross members

2.k. Rajasekar Dr. R Saravanan [ISSN 2348- 7968 Volume 1; 7 Sept 2014]

“The chassis design of on-road heavy vehicles”

The present study has analyzed the various literature. After a careful analysis of various research studies conducted so far it has been found that sufficient studies have not been conducted on the variable section chassis concept. Hence in order to fill the gap future research studies may be conducted on the variable section chassis concept in automobiles.

3.Vijayan S.N. Sendhil kumar [Vol7,15697-15701,May 2015]

“Design and analysis of automotive chassis considering cross-section and material”

The existing heavy vehicle chassis of EICHER is considered for design and analysis with different cross-sections for different materials like S-Glass Epoxy composites is performed. The model of the chassis was created in Pro-E and analyzed with ANSYS for the same load conditions. After analysis comparison is made between existing conventional steel chassis and S-Glass Epoxy composite materials in terms of deformation and stresses, to select the best one.

4.M. Z. A Rashid, Marian Sulaiman [ISSN 1913- 1844, Volume no.9, 2015]

“Design and simulation study of small four-wheel vehicle chassis for a single driver”

This paper has presented a design for a four-wheel chassis design that can be occupied or driven by a single driver. The chassis structure selected is the space frame type chassis. A static test is also performed on the chassis design using the simulation function in the Solid works software. Then, the basic chassis frame structure is fabricated using the materials selected which is the 25mm x 25mm square mild steel nabe with a thickness of 1.6mm. The static test conducted using the simulation function in Solid work

software determines the Von Mises stress, resultant displacement, and equivalent strain experienced by the chassis frame structure. In the static test, the finest available mesh is chosen to increase the accuracy of the result obtained. Then, the results obtained are analyzed and discussed.

5.R. K. Kawade Mohan N S. [Volume.3, Issue 8, 2015]

“Chassis Frame Torsional Stiffness Analysis”

Finite element analysis can effectively solve the torsional stiffness analysis of the chassis frame. Two methods of stiffness analysis are carried out considering the wheelbase of the vehicle and considering the spring bracket loading. According to the comparison of simulated results spring bracket method is closer to the vehicle’s actual running condition and it is also evident that which higher than the wheelbase method. Spring Bracket method stiffness can be used in the vehicle handling analysis for increasing the accuracy of the results and also it will help to reduce the weight of the chassis frame by reducing the stiffness if it is higher than the required.

6.Himanshu Hiranman Rathod, Sanjay Kumar, Vinit Goel. [Volume .4, Issue 3,march 2018]

“Analysis and Design of Vehicle Chassis and its Materials”

The properties of various alternate materials like carbon fiber, aluminum alloy, and titanium have been studied and compared with conventional mild steel. After a careful analysis of various research studies conducted so far, it has been found that sufficient studies have not been conducted on variable section concept and trailer chassis. To predict the life of a chassis there is a need to research the base material for the load variation and impacting static as well as dynamic. To fulfill the gap, future research studies and analyses should be conducted on variable section chassis and trailer chassis concepts and also the material to be used in automobiles.

7.Evangelos Ch Tsirogiannis, Georgios E Stavroulakis and Sofoklis S. Makridis [31Jan,2018] “Electric Car Chassis for Shell Eco-Marathon Competition”:

Design, Modelling, and Finite Element Analysis Electric cars are becoming a promising solution for the near future. Hence, this work thoroughly explains the design, modeling, and simulation processes for an electric car’s chassis. The criteria of comparison for the best electric chassis design at the Shell Eco-Marathon are the weight, the strength, the ergonomics, and safety. The proposed electric car chassis is synonymous with lightweight engineering because of being the lightest chassis in the competition while it obeys ergonomic and safety rules. The innovation of this research work is the overcoming of the time-consuming process by using the chassis load calculator (CLC) model suitable for

an electric car. Furthermore, the methodology for the processing procedure through FEM, which was developed under a combined stress scenario and by using the exact vehicle's dynamic loads, would be suggested as an accurate ultrafast method. In the future, further studies with more loading cases and further optimization of dimensions and materials will be followed.

8.Ameya Dabhade, Khizar, A.Pathan [ISSN 0976-6480 volume11, issue 10 Oct 2020]

**“DESIGN AND DEVELOPMENT OF CHASSIS FOR FORMULA STUDENT VEHICLE”**

The manufactured design of the chassis satisfies all the objectives decided at the beginning. All dimensions of the three compartments viz. front, driver, and engine are the same as designed. Because of the kind of fixture developed, it saves a lot of manufacturing and protects the unnecessary investment in steel fixtures. Physical ergonomics gives crucial data about the positioning of different components and visibly aspect to a driver before complete manufacturing and assemblage of the vehicle.

### III. OVERVIEW OF CHASSIS

#### Definition of a Chassis

The chassis is the framework that is everything attached to it in a vehicle. In a modern vehicle, it is expected to fulfill the following functions:

- Provide mounting points for the suspensions, the steering mechanism, the engine and gearbox, the final drive, the fuel tank, and the seating for the occupants
- Provide rigidity for accurate handling
- Protect the occupants against external impact.
- While fulfilling these functions, the chassis should be light enough to reduce inertia and offer satisfactory performance. It should also be tough enough to resist fatigue loads that are produced due to interaction between the driver, engine, power transmission and road conditions.

#### Ladder frame

The history of the ladder frame chassis dates back to the times of the horse-drawn carriage. It was used for the construction of ‘body on chassis’ vehicles, which meant a separately constructed body was mounted on a rolling chassis. The chassis consisted of two parallel beams mounted down each side of the car where the front and rear axles were leaf sprung beam axles. The beams were mainly channeled sections with lateral cross members, hence the name. The main factor influencing the design was resistance to bending but there was no consideration of torsion stiffness.

A ladder frame acts as a grillage structure with the beams resisting the shear forces and bending loads. To increase the torsion stiffness of the ladder chassis cruciform bracing was added in the 1930s. The torque in the chassis was restrained

by placing the cruciform members in bending, although the connections between the beams and the cruciform must be rigid. Ladder frames were used in car construction until the 1950s but in racing only until the mid-1930s.

#### Design of chassis

##### 4seater

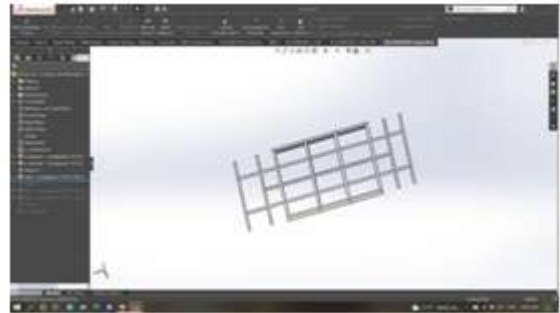

##### 6 seater

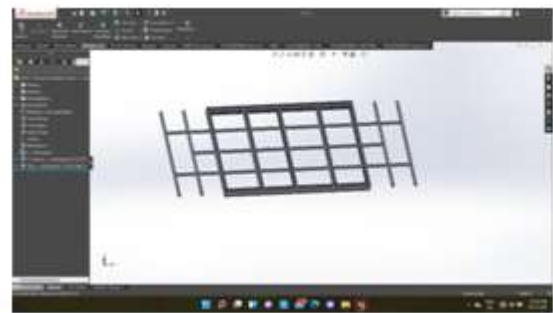

##### C-section

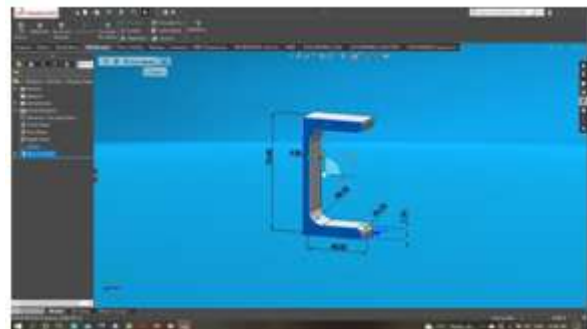

#### Testing of chassis (ANSYS)

This chapter discusses experimental and finite element analysis of the torsion test. The experimental torsion test was conducted in the laboratory by using the test rig that was specially designed for twisting load applications and the ANSYS simulation system for finite element analysis (FEA). Both of the results were compared and recorded for further analysis.

**Theory of load cases.**

A chassis is subjected to three load cases: bending, torsion, and dynamic loads. The bending (vertical symmetrical) load case occurs when both wheels on one axle of the vehicle encounter a symmetrical bump simultaneously. The suspension on this axle is displaced, and the compression of the springs causes an upward force on the suspension mounting points. This applies a bending moment to the chassis about a lateral axis.

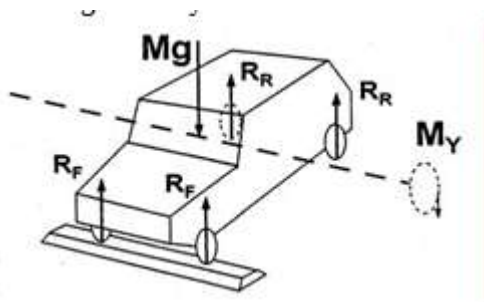

The torsion (vertical asymmetric) load case occurs when one wheel on an axle strikes a bump. This load is causing the chassis to torsion as well as bending. It has been found both in theory and in practice that torsion is a more severe load case than bending. The dynamic load case comprises longitudinal and lateral loads during acceleration, braking, and cornering. These loads are usually ignored when analyzing structural performance and this analysis will follow the free boundary condition procedures. A torsion stiffness chassis offers several advantages:

1. According to vehicle dynamics principles, for predictable and safe handling, the geometry of the suspension and steering must remain as designed. For instance, the camber, caster, and toe angles could change with torsion twist causing “bumpsteer.”
2. Once again according to vehicle dynamics principles, a suspension should be stiff and well-damped to obtain good handling. To this end the front suspension, chassis, and the rear suspension can be seen as three springs in series as shown in If the chassis is not

sufficiently stiff in torsion, then any advantages gained by stiff suspension will be lost.

**IV. OVERVIEW OF CHASSIS TYPE**

The chassis used for this analysis was Golf cart Chassis as shown in Fig. and it was described as a space frame chassis with a ladder-type structure. It was constructed from mild steel Rectangular C Section and its cross-section was supported by a mild steel sheet.

**Design dimensions for chassis frame**

**1) Initial chassis**

	4-seater	6-seater
length	1500 mm	1900 mm
width	2600 mm	3350 mm
Front overhang	600 mm	700 mm
Rare overhang	500 mm	700

**2) C-section**

length	75 mm	75 mm
width	40 mm	40 mm
thickness	4.80 mm	4.80 mm

**3) Final chassis**

	6-seater
length	3648.2 mm
width	1900 mm
Front overhang	350 mm
Rare overhang	350 mm

**Final Chassis design**

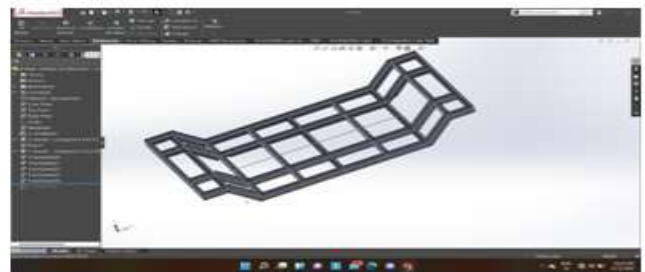

**Ansys testing**  
**Initial chassis**

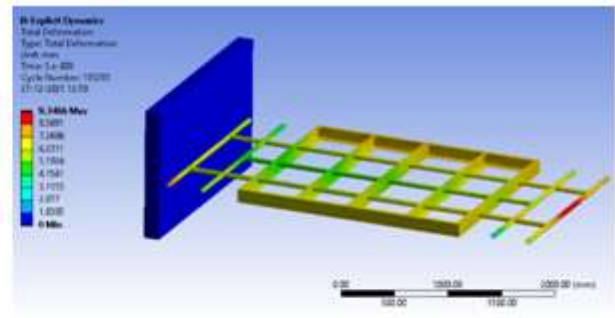
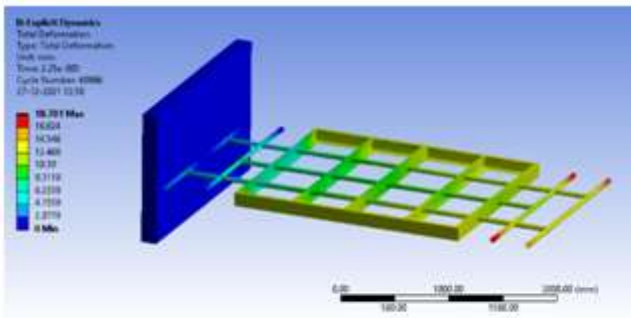

**Final chassis**

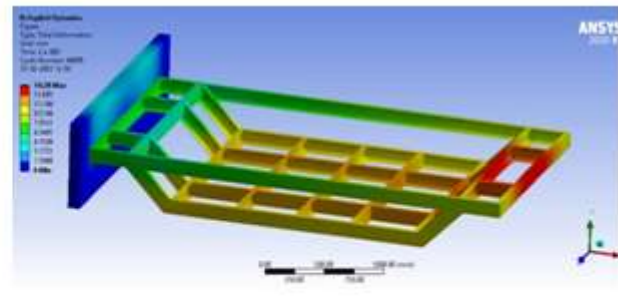
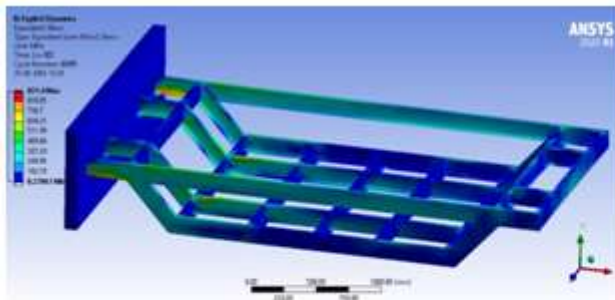

**V. CONCLUSION**

In the present work, a ladder-type chassis frame for campus drive vehicles was designed and analyzed. Based on the analysis results of the present work, the following conclusions can be drawn.

- 1) Part is safe under the given loading condition. (4-seater 500 kg) (6-seater= 700 kg).
- 2) The new chassis frame was analyzed and the part is safe under the load conditions which is 1000kg.
- 3) To improve performance, geometry has been modified which enables the reduction of stress levels marginally well below the yield limit.
- 4) For Load conditions C cross-section chassis will be used.
- 5) All design and analysis for the chassis component had been conducted properly.
- 6) In This project also all students have increased soft skills such as leadership, teamwork, and spirit during accomplishment.

**VI. ACKNOWLEDGEMENT**

We would like to thank An antrao Pawar College of Engineering & Research for providing us with a platform to recite our success and get acknowledged by all our fellow technical and non-technical elements of society. We are always dedicated to the good of this engi-

neering community and their development fundamental so we can create technology that can bring joy, life, easy work, and leisure to human kind.

**VII. REFERENCES**

- [1]. Abhishek Singh, et al, "Structural Analysis of Ladder Chassis for Higher Strength", International Journal of Emerging Technology and Advanced Engineering, ISSN: 2250-2459, Volume 4, Issue 2, February 2014.
- [2]. Patel Vijay kumar, et al, "Structural Analysis of Automotive Chassis Frame and Design Modification for Weight Reduction", International Journal of Engineering Research & Technology, ISSN: 2278-0181, Volume 1, Issue 3, May 2012.
- [3]. Vishal Francis, et al, "Structural Analysis of Ladder Chassis Frame for Jeep Using Ansys", International Journal of Modern Engineering Research, ISSN: 2249-6645, Volume 4, Issue 4, April 2014.
- [4]. Monika S. Agarwal, et al, "Finite Element Analysis of Truck Chassis", International Journal of Engineering Sciences & Research, ISSN: 2277-9655, December 2013.
- [5]. "An introduction to a modern vehicle. Design" - Julian Happon, Smith
- [6]. "Designing chassis type structure" Florin Popa



- [7]. Peterbilt Essentials-module "Frame Components & Attachments"
- [8]. "Failure investigation and stress analysis of a longitudinal stringer of an automobile basis" v vellum, HS Magal hoes, GTBicalho

# IJEAST

INTERNATIONAL JOURNAL  
OF ENGINEERING APPLIED SCIENCE  
AND TECHNOLOGY

## ABOUT IJEAST

International Journal of Engineering Applied Science and Technology (IJEAST) is a peer-reviewed, open access journal that publishes high-quality research papers in the field of Engineering, Applied Science and Technology.

IJEAST aims to provide a platform for researchers, academicians, and professionals to share their innovative ideas, research findings, and practical experiences with the global scientific community.

## FOCUS AREAS

- Engineering
- Applied Science
- Technology
- Innovation & Development
- Interdisciplinary Studies



### PEER REVIEWED

All submissions are rigorously peer reviewed to ensure quality.



### OPEN ACCESS

Free and unrestricted access to research for all.



### GLOBAL REACH

Connecting researchers and professionals worldwide.



### TIMELY PUBLICATION

We ensure a swift and efficient publication process.



For more information, visit our website

[www.ijeast.com](http://www.ijeast.com)



INTERNATIONAL JOURNAL  
OF ENGINEERING APPLIED SCIENCE  
AND TECHNOLOGY

✉ [editor@ijeast.com](mailto:editor@ijeast.com)

🌐 [www.ijeast.com](http://www.ijeast.com)

📍 India



2455-2143