



# IJEAST

INTERNATIONAL JOURNAL  
OF ENGINEERING APPLIED SCIENCE  
AND TECHNOLOGY



**VOLUME : 5    ISSUE : 6    Print / Issue Publication Date: 21-Dec-2020**



**ISSN : 2455-2143**



**DOI : 10.33564/IJEAST.2020.v05i06.043**

Indexed In



[WWW.IJEAST.COM](http://WWW.IJEAST.COM)

[editor@ijeast.com](mailto:editor@ijeast.com)



# DEVELOPMENT OF GEARBOX FOR SUBMERSIBLE MIXER

Rahul Anil Vetal  
Department of Mechanical Engineering  
Rajarambapu Institute of Technology,  
Islampur, India

Dr. Sanjaykumar S. Gawade  
Department of Mechanical Engineering  
Rajarambapu Institute of Technology,  
Islampur, India

**Abstract**— Submersible mixer is mechanical device that is used to mix sludge and other liquid volumes. This submersible mixer used in sewage treatment plants. The working principle of submersible mixer is to operate by submersible electric motor which is coupled to the submersible mixer's propeller either direct coupled or planetary gear reducer. Propeller rotates and creates liquid flow in the tank which in turn keeps the solids in suspension, due to turbulence /agitation. Planetary gearbox are extensively used for the power transmission and are the most critical component. The project deals with selection of planetary gearbox for particular mixer. Also the development of gearbox casing, propeller hub for the same mixer is done.

**Keywords**— Submersible mixer, Waste water, Gear train, Torque density, Propeller hub

## I. INTRODUCTION

A mechanical device known as Submersible mixer is used in Sewage Treatment plants to mix the sludge and other liquid components. The functioning principle of such submersible sludge mixer is to operate by submersible electronic motor which is accompanied to the submersible mixer's propeller by using either direct coupling or by using planetary gear reducers. The liquid keeps owing in the tank which keeps the solids present in sludge in suspension due to turbulence /agitation of rotating propeller.

Sewage treatment plant consist of several activities preliminary treatment, primary treatment, secondary treatment, tertiary treatment and sludge treatment. During preliminary treatment, screens are used to remove large, solid inorganic materials such as paper and plastic.

During primary treatment, the wastewater passes through a sedimentation tank to remove smaller, solid organic materials using a gravity settling process. During the secondary treatment stage, an activated sludge process uses submersible mixers to break down any dissolved or suspended organic solids. This is followed by the tertiary treatment stage in which disinfectants, usually chlorine, are mixed into the water to eliminate harmful microbes. Finally, during the sludge treatment stage, the collected sludge is processed for reuse.

Submersible mixer is the main part of the sewage treatment plant used to mix the sludge. The mixer can be driven by different types of gearboxes. To select the planetary gearbox system for six types of mixers operating at speed range in between 30 rpm to 80 rpm such that mixer should operate at low speed for effective mixing. Also develop the assembly drawing

for selected gearbox using solid works software & manufacture all the gearboxes. Finally carryout the testing of gear box with submersible motor and propeller with the help of test bed facilities and validate results for same. Hence the focus is a designing the planetary gearbox with various modifications necessary to reduce the speed of submersible mixer.

## II. LITERATURE REVIEW

Several researchers had worked on the development of planetary gearbox for submersible mixer for different applications. Several different approaches can be found in the literature. Some of the recent studies are explained below.

Mr. Akshay Shrishrimal et.al [1] have studied design of high reduction ratio of two stage planetary gear train. In the design of planetary gear box system, due consideration is to be given while finding the value of reduction ratios of the gear box, maximum and minimum reductions per single stage of planetary gear pairs. Even, the case study is mentioned to find the reduction ratio of the two stage gearbox. The planetary gear box system is designed, stimulated through SolidWorks and actual testing is done.

Mr. M. R. Rawal & Mr. S. S. Sutar [2] have studied torque measurement in epicyclic gear train. Input, output and holding or braking torque are determined from practically conducted experimental set up and analytically calculations by using tabular equations for rotation per minute ranging from 1000 rotations per minute to 2800 rotations per minute. The experimental and analytical results were compared which was showing an error ranging from 6 % to 8%. This error accumulated was due to some mechanical losses. Holding and frictional losses. That are occurring while performing the experiment. Braking torque in epicyclic gear train was also calculated in this study by using analytical calculations and experimental setup.

**Prof. Bhavin Gajjar & Mr. Mahesh Dobariya [3]** worked on design of compound planetary gear train. These planetary gear trains is commonly used in several areas industries. Parts of planetary gear trains are very critical which leads to failure of whole transmission due to failure of one gear. Hence it is very essential to find out the reason of failure, so that such failures will not happen again. Planetary Gear Trains have has many benefits in industry. This beneficial side includes comparatively smaller size, high torque/weight ratio, highly compact package, improved efficiency, etc.

**J.S. Athreya et.al [4]** have studied design and fabrication of



epicyclic gearbox which represents the benefits of planetary gear box systems over other systems, The paper also stated that, due consideration must be given to find out the reducing ratio of gear box, maximum and minimum reduction ratios for every stage of planetary type gear pair. Even the studied case, which is determining the reduction ratio of two staged planetary type gear box is also discussed in detail.

**Mr. Sandeep Belgamwar et.al [5]** have studied design and analysis of planetary gearbox for industrial concrete mixer, which helps in manufacturing the planetary gear pair essential for an huge industrial concrete mixer. Instead of providing an individual source of power to cause the planet like motion, a gear drive can be utilized which reduces the power consumption of the machine. Hence mechanical efficiency is improved. This paper also helps in determining the probable cause by which the gear pair will fail, as well as countermeasures to prevent its failure. They have also studied the properties of the lubricant which is to be used in the gearbox, and the reason for its selection.

**Mr. Adarsh Kumar et.al [6]** have studied optimization skill of epicyclic gear train and their failure. It has been investigated that cost of higher volume gearbox is depending upon cost of material and mass of gears used. It is critical to determine an optimum relation between given space and weight restrictions of gear. The study deeply focuses on design rectification and optimizations. Further it is concluded that the design constraints like number of planets, number of teeth, face

Widths, material used, modules and tooth profile modification are very significant in determining the cost of gear, life durability, and its load capacity in bending and wear. After applying optimization techniques, the weight of epicyclic gearbox housing must be reduced. Finite Element Analysis method should be used to examine whether the optimized design of epicyclic gearbox housing is safe or not.

**Prof. Tristan M. Ericson & Robert G. Parker [7]** worked on experimental measurement of torque to study the dynamic performance and system characteristics of planetary type gears. In that testing of model, number of experiments were conducted on a spur type planetary gear at rest through a wide range of torques introduced on gear. The vibrations of each and every independent gear component parts are the examined by using accelerometers assembled on the body of gear near the meshing teeth.

Natural frequencies obtained are then differentiated to the guess the model of analytical lumped-parameter. Bearing stiffness of planetary gear bearing stiffness and the stiffness of mesh will affect the high-frequency of gear modes.

**Mr. S.N. Shaikh et.al [8]** have studied about reduction in noise level of planetary gear sets. This research is primarily focused to reduce noise in planetary gear set by different phase arrangement. The Planetary gears are highly famous for transmission of power and widely used in industrial sectors like air craft engines, automobiles, heavy machinery, helicopters, and several other sectors. In spite of its several benefits, there negative impression on customers thinking of quality from vibration related issue and large noise produced. This remains a key concern. Therefore several different

methodologies have been initiated in recent years in order to reduce the vibrations induced noise in gears. An experimental procedure was conducted to study the consequence of planet phasing on the Vibrations produced in planetary gear box. Many experimental procedures were constructed for two different types of arrangements of gear i.e. with phasing and without phasing. And hence, it is seen that by use of planet phasing arrangement, level of noise and vibrations produced were reduced subsequently. Hence it was concluded that, by the utilization of coupling phase difference, we can minimize the vibrations and noise in planetary gear set.

**Prof. Nenad Marjanovic et.al [9]** have presented an innovative philosophy of the two staged cycloidal speed reducing, where just a single cycloid disc is utilized in every stage. Torque equations on concerned element of the reducer were given. Even the expression for determining the contact forces on the teeth of cycloid disc were also provided. Mathematical investigation of the stress-strain curve for the important parts of the reducer (i.e., central disc, cycloid disc, rotatable ring gear of the second stage, stationary ring gear of the stage and eccentric) was as well understood. By using a strain gauges method, an experimental procedure was investigated to analyze the state of stress of the cycloid disc in first stage.

**Mr. Anoop Verma et.al [10]** worked on optimization of wastewater treatment aeration process. They oriented on quality of water. Several large industries such as water treatment plant or wastewater treatment plant, generally tends to look over probable savings in consumption of energy. The process involved in wastewater treatment plant consists of energy intensive machines such as blowers and pumps, to keep the waste water moving. Currently, a data-driven method is utilized for aeration process modeling and optimization of single large scale Waste water. A typical aeration process energy optimization is conducted with a target to minimize the use of energy without oblation to water quality.

**Mr. Shahid Raza & Saima Hanif [11]** worked on domestic waste water treatment systems, waste water treatment technologies; composing of wet land and toilets. The water that under goes to drainage from toilets and water closets of homes, offices, schools, factories and business center is called as waste water, which is dirty. This dirty waste water is then collected in a network of pipes so called as Sewers. These sewers carries the waste water to wastewater treatment plants. At these waste water treatment plants, the waste water is cleaned at different stages via different processes before it is put back into the river. Basically, the waste material in wastewater is toxic and can endanger the healthy life of humans and lives in river water. This toxic wastes should be taken out of the water and disposed of safely. Although the water is a non-renewable precious resource and must be reversed to natural water cycle in good quality. Standard waste treatment systems, including both sewer and septic systems are polluted by design.

### III. SELECTION OF GEARBOX

#### a) Some important parameters of gearbox selection

##### 1. Speed(n)

Input Speed ( $n_1$ ):-It specifies at actual pace of input to the gearbox. Output Speed ( $n_2$ ):-It specifies at actual pace of output



from the gearbox. Reduction ratio (i) -It is the ratio of Actual input speed to actual output speed.

**2. Torque ratings**

In that case two types of torque ratings i.e. continuous torque rating and peak torque rating.

**3. Lifetime (n2 x h)**

The multiplication of pace of output with the `h' hour duration is termed as lifetime. It shows a number which is in direct proportion to the stress introduced on the part element, which restricts the working life durability of the gear box. To correspond the pace and the duration in `h' hour, the torque is derived from a mathematical formulae as n2 x h. With the pace n2 and the torque Mtcon essential, the period in `h' hours can be determined, or else, if the pace and the time taken in `h' hour's essential are known, and then the Mtcon which the gear box can transfer will be determined.

**4. Service factor (Fs)**

This factor depends upon the application type table1. It have taken into consideration that, variation in load which the gear box may experience for the particular type of duty. The chosen drive unit type, for e.g. electrically operated motor, hydraulically operated motor and so on, is also taken into consideration and it Should be selected from table 1.

Power Source	Duration of working in Hours per day	Load Classification		
		UniformShock	Moderate shock	Heavy shock
Electric motor, steam turbine or hydraulic motor	Under -3	0.80	1.00	1.50
	3 to 10	1.00	1.25	1.75
	Over - 10	1.25	1.50	2.00
Multi-cylinder internal combustion engine	Under -3	1.00	1.25	1.75
	3 to 10	1.25	1.50	2.00
	Over - 10	1.50	1.75	2.25
Single cylinder internal combustion engine	Under -3	1.25	1.50	2.00
	3 to 10	1.50	1.75	2.25
	Over - 10	1.75	2.00	2.50

Table 1- Selection of service factor

**5. Selection of reduction unit:-**

Details essential for selecting the reduction unit:

Reducers selected are solely based on the output torque capacity required, for a specified duration of time. The method of service factor is utilized to apply specified industrial using standards on the basis of per day hours of working.

$$\text{Reducer ratio} = \text{Input speed} / \text{Output speed}$$

**6. Output torque (Nm) =  $\frac{7123.77 \times \text{HP} \times \text{fs} \times \text{Efficiency}}{\text{Output speed}}$**

**7. Standard reduction ratio calculated table as shown below**

Ratio		Total	Input	Output
Stage-I	Stage-II	Ratio	rpm	
6.00	6.00	36.0	1440	40.0
6.00	5.06	30.4	1440	47.4
5.06	6.00	30.4	1440	47.4
6.00	4.42	26.5	1440	54.3
4.42	6.00	26.5	1440	54.3
5.06	5.06	25.6	1440	56.2
6.00	3.95	23.7	1440	60.8
3.95	6.00	23.7	1440	60.8
5.06	4.42	22.4	1440	64.4
4.42	5.06	22.4	1440	64.4
6.00	3.60	21.6	1440	66.7
3.60	6.00	21.6	1440	66.7
5.06	3.95	20.0	1440	72.0
3.95	5.06	20.0	1440	72.0
4.42	4.42	19.5	1440	73.7
5.06	3.60	18.2	1440	79.1
3.60	5.06	18.2	1440	79.1
4.42	3.95	17.5	1440	82.5
3.95	4.42	17.5	1440	82.5
4.42	3.60	15.9	1440	90.5
3.60	4.42	15.9	1440	90.5
3.95	3.95	15.6	1440	92.3
3.95	3.60	14.2	1440	101.3
3.60	3.95	14.2	1440	101.3
3.60	3.60	13.0	1440	111.1

Table2. Selection of reduction unit

**8. Various planetary gearbox selection tables**

Sr. No	Input Data						Actual Ratio	Output rpm =input rpm /ratio	Output Torque Nm	S.F.	Model
	Motor rating		Frame Size	Gr. Box rpm	Pol es	Target					
	Hp	Rpm									
1	5	1414	4	112	80	17.45	81	444	3.0	9040-2	
2	7.5	1414	4	112	40	35.35	39.28	1375	2.25	9050-2	
3	5	1414	4	112	50	26.50	53.36	675	2	9040-2	
4	5	1414	4	112	35	36	39	930	3.2	9050-2	
5	5	1414	4	112	40	36.00	39.28	917	3.4	9050-2	
7	5	950	6	132	30	30.36	31.29	1150	2.7	9050-2	
8	7.5	1414	4	112	40	36.00	39.28	1375	2.3	9050-2	
9	10	1440	4	132	50	30.36	47.43	1518	2.0	9050-2	
10	3	1378	4	90	52	26.50	52.00	415	3.25	9040-2	
11	5	720	8	160	85	13.00	55.38	650	4.8	9040-2	
12	7.5	947	6	132	43	22.40	42.28	1277	2.4	9050-02	
13	7.5	720	8	160	43	17.50	41.14	1313	2.4	9050-2	
14	10	1425	4	112	43	36.00	39.58	1819	1.7	9050-2	
15	10	939	6	132	43	22.40	41.92	1718	1.8	9050-2	
16	10	720	8	160	43	17.50	41.14	1756	1.8	9050-2	

Table 3- Gearbox selection

**9. Selection of Planetary gear data**

**1. Selection of Sun Gear**

<b>Gear Data</b>	<b>External</b>
No. of Teeth	13
Module	2.5
Pitch Diameter	32.5
Correction (X)	0.297
Pressure Angle	20 <sup>0</sup>
Span over teeth	2
Span Measurement (Before Grinding)	12.483
	12.444
Span Measurement (After Grinding)	11.983
	11.955
Quality of Gear	6 Class

Table 1- Sun gear data

2. Selection of Planet gear

<b>Gear Data</b>	<b>External</b>
No. of Teeth	25
Module	2.5
Pitch Diameter	62.5
Correction (X)	0.3674
Pressure Angle	20 <sup>0</sup>
Span over teeth	4
Span Measurement	27.269
	27.231
Quality of Gear	6 Class

Table 2- Planet gear data

3. Selection of Ring gear

<b>Gear Data</b>	<b>External</b>
No. of Teeth	65
Module	2.5
Pitch Diameter	162.5
Correction (X)	0
Pressure Angle	20 <sup>0</sup>
Pin Dia.	5.0 <sup>±0.01</sup>
Span Measurement	153.486
	153.666
Quality of Gear	6 Class

Table 3- Ring gear data

In all these calculations I have chosen the model for manufacturing is 9050-2.

Standard data for model 9050-2 are given below

1. Input data – Prime mover- Electric motor 2.Type – Hollow keyed 3. Input power – 5HP 4. Input speed – 1440 rpm 5. Mounting -112 FS Standard.

2 Output Data – Type – Solid keyed 2. Size – Dia.40mm 3. Output speed – 40 rpm.

**B) Material Selection of submersible mixer components**

Depending on the liquid in which our submersible mixer is required, material of the gear box need to be selected. For efficient mixing purpose, we have designed outside shape of the casting for gearbox to match our propeller and electric motor.

The materials which are used for the submersible mixer depends upon the service factor and strength like wear or noise conditions etc. and they came in metallic and nonmetallic form.

Sr.no	Type of material	Corrosion resistance	Strength	Machinability	cost	Total
1	Cast iron	1	2	4	2	9
2	SFI	2	3	3	3	11
2	Mild steel	2	3	4	3	12
3	WCB Steel	4	3	4	4	15

**C) CAD model of the components**

1. Assembly model of Submersible mixer

The final CAD modelling of submersible mixer components and its assembly is done using solid work software. The assembly of submersible mixer will look like as shown in below.

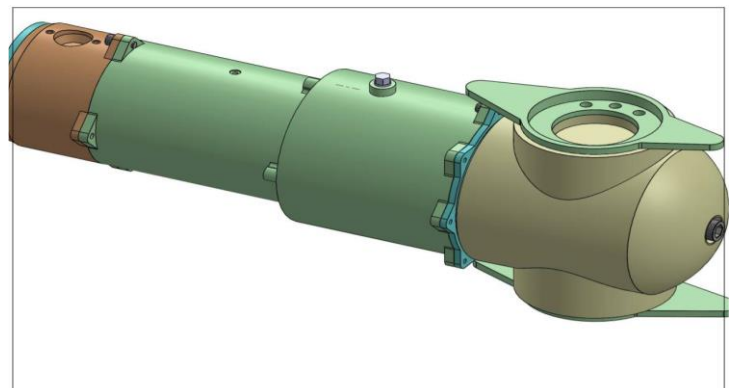

Figure1. CAD model of submersible mixer

2. CAD model of planetary gearbox

The CAD modelling of gearbox and its assembly is done using solid work software. The assembly of gearbox will look like as shown in below.

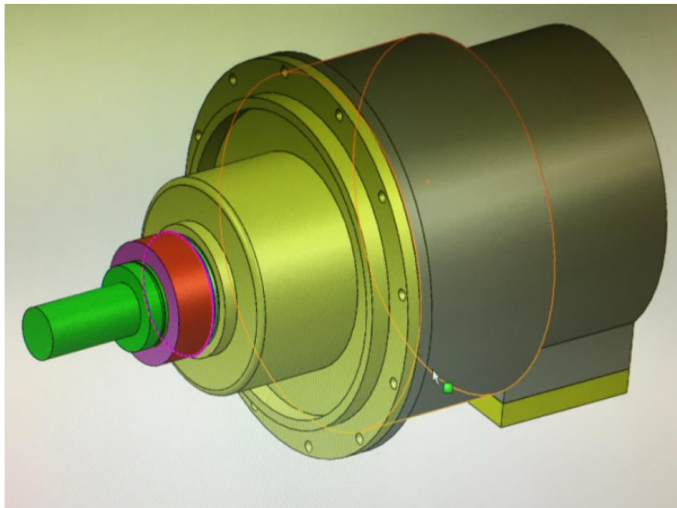

Figure2. CAD of planetary gearbox

#### D) Manufacture, Assembly and Testing Of Gearbox

##### 1. Gears manufacturing

The gears in the gearbox are fabricated using various manufacturing processes to create the final product .i.e. casting, milling, hobbing, sharing, and induction hardening.

##### 2. Assembly of Submersible mixer Component-

An assembly line is a production procedure where different component parts (usually interchangeable parts) are added on this line as the semi-finished component parts, which is moved from working station to a station of assembling these parts in a particular sequence till the final product manufactured. By taking the com-opponent parts mechanically to the place of assembly work and moving the semi-finished assembly from work station to assembly station, a well prepared product can be assembled quickly and that too with less labor than by having workers to carry the stationary piece for assembly..



Figure 2 Assembly of Motor and Gearbox

#### 3. Component Testing and final inspection

Manufacturer:Name & Address						Manufacturing Quality Plan	
KISHOR PUMPS Pvt. Ltd						Item : GEARED SLOW SPEED SUBMERSIBLE MOTOR	
875/2, Pune Nasik Highway Kuruli, Chakan, Pune							
Sr. No.	Component & Operations	Gr	Material	Characteristics	Type of Check		
1	2	3	4	5	6		
<b>A Component Testing:</b>							
1.1	Motor casting parts (motor housing, top cover, oil chamber, adapter)	C	As per Data Sheet	Physical / Mechanical Properties	Physical / Mechanical Properties		
1.2	Shaft	W	AISI 410	Physical/Chemical & Mechanical Properties	Physical/Chemical & Mechanical Properties		
1.3	Cable	B	Cu conductor, with PVC insulation	Electrical properties	Conductivity, current carrying capacity		
1.4	Copper conductors	B	Copper modified polyester conductor	Electrical properties, dimensions	Conductivity, current carrying capacity		
1.5	Insulation sleeves, insulation papers,	B	Suitable to 'F' class of insulation	Electrical properties	Insulation resistance		
1.6	Banana Blades	B	Moulded PU	Soundness and Dimensions	Visual checking and dimensions		

Manufacturer:Name & Address						Manufacturing Quality Plan	
KISHOR PUMPS Pvt. Ltd						Item : GEARED SLOW SPEED SUBMERSIBLE MOTOR	
875/2, Pune Nasik Highway Kuruli, Chakan, Pune							
Sr. No.	Component & Operations	Gr	Material	Characteristics	Type of Check		
1	2	3	4	5	6		
<b>B Final Inspection</b>							
2.1	Motor casting parts (motor housing, top cover, oil chamber, adapter)	C	As per Data Sheet	Leakage-free	Airpressure test at 10 bar		
2.2	Motor casting parts (motor housing, top cover, oil chamber, adapter)	C	As per Data Sheet	As per drawings	Dimensions		
2.3	O' rings, mechanical seals	B	As per approved data sheets	As per drawings	Dimensions		
2.4	Machined shaft	W	AISI 410	Dye penetrant test	Surface defects		
2.5	Rotor-shaft assembly	W	-	Dynamic balancing test with rotor	Dynamic balancing		
2.6	Complete motor assembly	-	-	Visual checking and dimensions	Visual checking and dimensions		
2.7	Motor performance test	-	-	Routine tests	Resistance of winding of stator		
				No-load test	No-load losses & current		
				Reduced voltage running up test	Reduced voltage running up test		
				HV Test	HV Test		

#### 4. Mixer Testing-

Manufacturer:Name & Address						Manufacturing Quality Plan	
KISHOR PUMPS Pvt. Ltd						Item : GEARED SLOW SPEED SUBMERSIBLE MOTOR	
875/2, Pune Nasik Highway Kuruli, Chakan, Pune							
Sr. No.	Component & Operations	Gr	Material	Characteristics	Type of Check	Acceptance Norm	
1	2	3	4	5	6	9	
				Noise	Noise	<= 85 dbA at 1.0 m	
				Vibration	Vibration	<= 83 microns	
	Mixer Testing			No-load test	Current, power, power factor	IEC 60034-1	
				Loading test at 3 m depth	Current	IEC 60034-1	
				Speed	RPM	IEC 60034-1	
				IP-68 testing of motor and gear box assembly	Submergence under water	No leakage	
				Leakage-free	Airpressure test at 10 bar	No leakage	
				Shaft power (bKW)	Shaft power (bKW)	IEC 60034-1	
				Noise	Noise	<= 85 dbA at 1.0 m	
				Vibration	Vibration	<= 83 microns	
				Mixer Dimensions	Dimensions	Mixer Dimension Drawing	

Legend :  
 1 : Subvender, 2 : KISHOR PUMPS, 3 : Customer, 4 : Supplier  
 C : Cast Component, W : Wrought / bar / sheet component, B : Bought-out component  
 \* : Other materials available on request



#### 4. Procedure for Testing of planetary gearbox

##### 4.1 Methods for Inspecting a Gearbox

1. Visual walk around 2. Visual inspection through inspection ports 3. Bore scope inspection 4. Measure temperature 5. Thermometers 6. Resistance temperature detector (RTD) probes 7. Thermography 8. Measure oil pressure 9. Measure sound and vibration 10. Inspect filter elements 11. On-site analysis of lubricant 12. Laboratory analysis of lubricant 13. Magnetic particle inspection of gears 14. Dye penetrant inspection of gears 15. Documenting gear condition - Written, Sketches, Photography, Contact patterns.

##### 4.2 Measure Gear Backlash and Shaft Endplay

Mount a dial indicator to measure the gear backlash, such that it is identical to a pinion tooth profile. Rotation of gear is prevented and the pinion is rocked through the backlash. A dial is again mounted to measure the shaft end play at the end of a shaft and the shaft is moved in axial direction. In many cases, this measurement requires a fixture with an arrangement of ball bearing on the central shaft that permits the pushing and pulling of shaft while it is in motion to seat the bearing rollers.

##### 4.3 Gear Mesh Alignment

Gears have higher load carrying capacity when the shaft of gear is perfectly aligned and the load transmitted is distributed uniformly over the complete active face width. Unluckily, many parameters such as design issues, deflection, manufacturing accuracy, external effects and thermal distortion may come together to cause misalignment of gear mesh. This result is due to misalignment and non-uniform distribution of load over gears.

Key features and parameters during the full load testing:

- Vibration levels
- Sound power levels
- Oil cleanliness
- Temperatures - Lubrication system & Bearings
- Lubrication o Pressures o Functionality
- Possible leakages
- Gear Contact Patterns

The traditional full load test run is to guarantee successful component manufacturing, refurbishment and assembly process.

The test run itself is not to improve quality – it is a quality assurance process.

The spin test the basic principal of testing is to mount the gearbox and spin it with a motor coupling to the high-speed pinion.

#### IV. CONCLUSION

We have modified the shape of propeller hub for a low speed aerodynamics resistance for effective mixing. Also we have changed the shaft design by considering the thickness of hub, bearing housing, and gearbox housing. Also depending on the

liquid in which our submersible mixer is required, material to be selected. Therefore by considering the design input the proper selection of the gearbox is done.

Also CAD modelling of gearbox housing, bearing housing, propeller hub and shaft is done. Manufacturing of submersible mixer components are done.

#### ACKNOWLEDGMENT

We would like to thank the researchers as well as publishers for making their resources available and teachers for their guidance. We are also thankful to reviewer for their valuable suggestions. We also thank the college authorities for providing the required infrastructure and support. Finally, we would like to extend a heartfelt gratitude to friends and family members.

#### V. REFERENCE

1. Mr. Akshay Shrishrimal “Design of two stage planetary gear train for high reduction ratio”. International Journal of Advance Engineering and Research Development Volume 5, Issue 01, January -2018.
2. Prof. M. R. Rawal “Torque measurement in epicyclic” gear train International Journal of Engineering and Advanced Technology (IJEAT) ISSN: 2249 – 8958, Volume-5, Issue-6, August 2016.
3. Prof. Bhavin Gajjar “Design of compound planetary gear train” International Journal for Research in Applied Science & Engineering Technology (IJRASET) ISSN: 2321-9653; IC Value: 45.98; SJ Impact Factor: 6.887 Volume 6 Issue IV, April 2018.
4. J.S. Athreya “Design and fabrication of epicyclic gear box” International Journal of Advanced Research in Computer and Communication Engineering (IJARCCE) ISO 3297:2007 Certified. Vol. 6, Issue 4, April 2017.
5. Mr. Sandeep Belgamwar “Design and analysis of planetary gearbox for industrial concrete mixer” International Journal of Latest Research in Engineering and Technology (IJLRET) ISSN: 2454-5031 Volume 2 Issue 4 | April 2016.
6. Mr. Adarsh Kumar “optimization technique of epicyclic gear train and failure of gears” International Research Journal of Engineering and Technology (IRJET) e-ISSN: 23950056 Volume: 05 Issue: 03 | Mar-2018.
7. Prof. Tristan M. Ericson “Experimental measurement of the effects of torque on the dynamic behavior and system parameters of planetary gears” Mechanism and Machine Theory journal homepage.
8. Mr. S.N. Shaikh “Noise level reduction in planetary gear set” Journal of Mechanical Design and Vibration, 2014, Vol. 2.
9. Mr. Gani Balbayev et.al [10] studied CAD design of a new planetary gear transmission (IJTR) INTERNATIONAL JOURNAL OF INNOVATIVE
10. ASTM -A240 standard.

# IJEAST

INTERNATIONAL JOURNAL  
OF ENGINEERING APPLIED SCIENCE  
AND TECHNOLOGY

## ABOUT IJEAST

International Journal of Engineering Applied Science and Technology (IJEAST) is a peer-reviewed, open access journal that publishes high-quality research papers in the field of Engineering, Applied Science and Technology.

IJEAST aims to provide a platform for researchers, academicians, and professionals to share their innovative ideas, research findings, and practical experiences with the global scientific community.

## FOCUS AREAS

- Engineering
- Applied Science
- Technology
- Innovation & Development
- Interdisciplinary Studies



### PEER REVIEWED

All submissions are rigorously peer reviewed to ensure quality.



### OPEN ACCESS

Free and unrestricted access to research for all.



### GLOBAL REACH

Connecting researchers and professionals worldwide.



### TIMELY PUBLICATION

We ensure a swift and efficient publication process.



For more information, visit our website

[www.ijeast.com](http://www.ijeast.com)



INTERNATIONAL JOURNAL  
OF ENGINEERING APPLIED SCIENCE  
AND TECHNOLOGY

✉ [editor@ijeast.com](mailto:editor@ijeast.com)

🌐 [www.ijeast.com](http://www.ijeast.com)

📍 India



2455-2143