



IJEAST

INTERNATIONAL JOURNAL
OF ENGINEERING APPLIED SCIENCE
AND TECHNOLOGY



VOLUME : 7 ISSUE : 08 Print / Issue Publication Date: 10-Feb-2023



ISSN : 2455-2143



DOI : 10.33564/IJEAST.2022.v07i08.004

Indexed In



WWW.IJEAST.COM

editor@ijeast.com



A REVIEW STUDY ON INSTRUMENTATION AND CONTROL ENGINEERING

Dr. Osama Mohammed Elmardi Suleiman Khayal

Associate Professor, Department of Mechanical Engineering

Faculty of Engineering and Technology, Nile Valley University, Atbara, River Nile State, Sudan

Abstract: In the present review, instrumentation and control engineering (ICE) is defined as a branch of engineering that studies the measurement and control of process variables, and the design and implementation of systems that incorporate them.

Instrumentation and control engineering (ICE) combines two branches of engineering. Instrumentation engineering is the science of the measurement and control of process variables within a production or manufacturing area. Meanwhile, control engineering, also called control systems engineering, is the engineering discipline that applies control theory to design systems with desired behaviors.

Control engineers are responsible for the research, design, and development of control devices and systems, typically in manufacturing facilities and process plants. Control methods employ sensors to measure the output variable of the device and provide feedback to the controller so that it can make corrections toward desired performance. Automatic control manages a device without the need of human inputs for correction, such as cruise control for regulating a car's speed.

In the present study a comprehensive review study on instrumentation and control engineering have been presented. The study was considered from different viewpoints which includes general introduction to instrumentation and control engineering; a comprehensive instrumentation that deliberates the present subject from the consideration of introduction, historical background and development, applications, measurement parameters, instrumentation engineering, impact of modern development; control engineering from the consideration of introduction, overview, history, control theory, control systems, control engineering education, control engineering careers, and recent advancement; and the last section is the conclusions.

I. INTRODUCTION

Instrumentation and control engineering (ICE) is a branch of engineering that studies the measurement and control of process variables, and the design and implementation of systems that incorporate them. Process variables in instrumentation and control engineering may include pressure, temperature, humidity, flow, pH, force and speed.

ICE combines two branches of engineering. Instrumentation engineering is the science of the measurement and control of process variables within a production or manufacturing area [1]. Meanwhile, control engineering, also called control systems engineering, is the engineering discipline that applies control theory to design systems with desired behaviors.

Control engineers are responsible for the research, design, and development of control devices and systems, typically in manufacturing facilities and process plants. Control methods employ sensors to measure the output variable of the device and provide feedback to the controller so that it can make corrections toward desired performance. Automatic control manages a device without the need of human inputs for correction, such as cruise control for regulating a car's speed.

Control systems engineering activities are multi-disciplinary in nature. They focus on the implementation of control systems, mainly derived by mathematical modeling. Because instrumentation and control play a significant role in gathering information from a system and changing its parameters, they are a key part of control loops.

High demand for engineering professionals is found in the fields associated with process automation and engineering systems control. Specializations include industrial instrumentation, system dynamics, process control, and control systems. Additionally, technological knowledge, particularly in computer systems, is essential to the job of an instrumentation and control engineer; important technology-related topics include human-computer interaction, programmable logic controllers, and SCADA. The tasks center on designing, developing, maintaining and managing control systems [2].

The goals of the work of an instrumentation and control engineer are to maximize productivity, optimization, stability, reliability, safety and continuity.

Many universities teach instrumentation and control engineering as an academic courses at the graduate and postgraduate levels. It is possible to approach this field coming from many standard engineering backgrounds, being the most common among them Electrical and Mechanical Engineering, since these branches cover strong foundational subjects in control systems, system dynamics, electro-mechanical machines and devices, as well as electric circuits.

II. INSTRUMENTATION

2.1 Introduction

Instrumentation is a collective term for measuring instruments that are used for indicating, measuring and recording physical quantities. The term has its origins in the art and science of scientific instrument making.

Instrumentation can refer to devices as simple as direct reading thermometers, or as complex as multi-sensor components of industrial control systems. Today, instruments can be found in laboratories, refineries, factories and vehicles, as well as in everyday household use (e.g., smoke detectors and thermostats)

2.2 Historical Background and Development

The history of instrumentation can be divided into several phases.

2.2.1 Pre - Industrial

Elements of industrial instrumentation have long histories. Scales for comparing weights and simple pointers to indicate position are ancient technologies. Some of the earliest measurements were of time. One of the oldest water clocks was found in the tomb of the ancient Egyptian pharaoh Amenhotep I, who was buried around 1500 BCE [3]. Improvements were incorporated in the clocks. By 270 BCE they had the rudiments of an automatic control system device [4].

In 1663 Christopher Wren presented the Royal Society with a design for a "weather clock". A drawing shows meteorological sensors moving pens over paper driven by clockwork. Such devices did not become standard in meteorology for two centuries [5]. The concept has remained virtually unchanged as evidenced by pneumatic chart recorders, where a pressurized bellows displaces a pen. Integrating sensors, displays, recorders and controls was uncommon until the industrial revolution, limited by both need and practicality.

2.2.2 Early Industrial

Early systems used direct process connections to local control panels for control and indication, which from the early 1930s saw the introduction of pneumatic transmitters and automatic 3-term (PID) controllers.

The ranges of pneumatic transmitters were defined by the need to control valves and actuators in the field. Typically a signal ranged from 3 to 15 psi (20 to 100 kPa or 0.2 to 1.0 kg/cm²) as a standard, was standardized with 6 to 30 psi occasionally being used for larger valves. Transistor electronics enabled wiring to replace pipes, initially with a range of 20 to 100 mA at up to 90V for loop powered devices, reducing to 4 to 20 mA at 12 to 24V in more modern systems. A transmitter is a device that produces an output signal, often in the form of a 4 – 20 mA electrical current signal, although many other options using voltage, frequency, pressure, or Ethernet are possible. The transistor was commercialized by the mid-1950s [6].

Instruments attached to a control system provided signals used to operate solenoids, valves, regulators, circuit breakers, relays and other devices. Such devices could control a desired output variable, and provide either remote or automated control capabilities.

Each instrument company introduced their own standard instrumentation signal, causing confusion until the 4 – 20 mA range was used as the standard electronic instrument signal for transmitters and valves. This signal was eventually standardized as ANSI/ISA S50, "Compatibility of Analog Signals for Electronic Industrial Process Instruments", in the 1970s. The transformation of instrumentation from mechanical pneumatic transmitters, controllers, and valves to electronic instruments reduced maintenance costs as electronic instruments were more dependable than mechanical instruments. This also increased efficiency and production due to their increase in accuracy. Pneumatics enjoyed some advantages, being favored in corrosive and explosive atmospheres [7].

2.2.3 Automatic Process Control

In the early years of process control, process indicators and control elements such as valves were monitored by an operator that walked around the unit adjusting the valves to obtain the desired temperatures, pressures, and flows. As technology evolved pneumatic controllers were invented and mounted in the field that monitored the process and controlled the valves. This reduced the amount of time process operators were needed to monitor the process. Later years the actual controllers were moved to a central room and signals were sent into the control room to monitor the process and outputs signals were sent to the final control element such as a valve to adjust the process as needed. These controllers and indicators were mounted on a wall called a control board. The operators stood in front of this board walking back and forth monitoring the process indicators. This again reduced the number and amount of time process operators were needed to walk around the units. The most standard pneumatic signal level used during these years was 3 – 15 psig[8].

Figure 1 below shows three term pneumatic PID controller, widely used before electronics became reliable and cheaper and safe to use in hazardous areas.



Figure 1 Three Term Pneumatic PID Controller

2.2.4 Large Integrated Computer - Based Systems

A DCS control room where plant information and controls are displayed on computer graphics screens. The operators are seated and can view and control any part of the process from their screens, whilst retaining a plant overview.

Process control of large industrial plants has evolved through many stages. Initially, control would be from panels local to the process plant. However process control of large industrial plants has evolved through many stages. Initially, control would be from panels local to the process plant. However this required a large manpower resource to attend to these dispersed panels, and there was no overall view of the process. The next logical development was the transmission of all plant measurements to a permanently-manned central control room. Effectively this was the centralization of all the localized panels, with the advantages of lower manning levels and easier overview of the process. Often the controllers were behind the control room panels, and all automatic and manual control outputs were transmitted back to plant.

However, whilst providing a central control focus, this arrangement was inflexible as each control loop had its own controller hardware, and continual operator movement within the control room was required to view different parts of the process. With coming of electronic processors and graphic displays it became possible to replace these discrete controllers with computer-based algorithms, hosted on a network of input/output racks with their own control processors. These could be distributed around plant, and communicate with the graphic display in the control room or rooms. The distributed control concept was born.

The introduction of DCSs and SCADA allowed easy interconnection and re-configuration of plant controls such as cascaded loops and interlocks, and easy interfacing with other production computer systems. It enabled sophisticated alarm handling, introduced automatic event logging, removed the need for physical records such as chart recorders, allowed the control racks to be networked and thereby located locally to plant to reduce cabling runs, and provided high level overviews of plant status and production levels.

Figure 2 below shows a pre-DCS/SCADA era central control room. Whilst the controls are centralized in one place, they are still discrete and not integrated into one system.



Figure 2 a Pre-DCS/SCADA Era Central Control Room

Figure 3 below shows A DCS control room where plant information and controls are displayed on computer graphics screens. The operators are seated and can view and control any part of the process from their screens, whilst retaining a plant overview.



Figure 3 a DCS Control Room

2.3 Applications

In some cases the sensor is a very minor element of the mechanism. Digital cameras and wristwatches might technically meet the loose definition of instrumentation because they record and/or display sensed information. Under most circumstances neither would be called instrumentation, but when used to measure the elapsed time of a race and to document the winner at the finish line, both would be called instrumentation.

2.3.1 Household

A very simple example of an instrumentation system is a mechanical thermostat, used to control a household furnace and thus to control room temperature. A typical unit senses temperature with a bi-metallic strip. It displays temperature by a needle on the free end of the strip. It activates the furnace by a mercury switch. As the switch is rotated by the strip, the mercury makes physical (and thus electrical) contact between electrodes.

Another example of an instrumentation system is a home security system. Such a system consists of sensors (motion detection, switches to detect door openings), simple algorithms to detect intrusion, local control (arm/disarm) and remote monitoring of the system so that the police can be summoned. Communication is an inherent part of the design. Kitchen appliances use sensors for control.

A refrigerator maintains a constant temperature by actuating the cooling system when the temperature becomes too high.

An automatic ice machine makes ice until a limit switch is thrown.

Pop - up bread toasters allow the time to be set.

Non-electronic gas ovens will regulate the temperature with a thermostat controlling the flow of gas to the gas burner. These may feature a sensor bulb sited within the main chamber of the oven. In addition, there may be a safety cut-



off flame supervision device: after ignition, the burner's control knob must be held for a short time in order for a sensor to become hot, and permit the flow of gas to the burner. If the safety sensor becomes cold, this may indicate the flame on the burner has become extinguished, and to prevent a continuous leak of gas the flow is stopped.

Electric ovens use a temperature sensor and will turn on heating elements when the temperature is too low. More advanced ovens will actuate fans in response to temperature sensors, to distribute heat or to cool.

A common toilet refills the water tank until a float closes the valve. The float is acting as a water level sensor.

2.3.2 Automotive

Modern automobiles have complex instrumentation. In addition to displays of engine rotational speed and vehicle linear speed, there are also displays of battery voltage and current, fluid levels, fluid temperatures, distance traveled and feedbacks of various controls (turn signals, parking brake, headlights, and transmission position). Cautions may be displayed for special problems (fuel low, check engine, tire pressure low, door ajar, seat belt unfastened). Problems are recorded so they can be reported to diagnostic equipment. Navigation systems can provide voice commands to reach a destination. Automotive instrumentation must be cheap and reliable over long periods in harsh environments. There may be independent airbag systems which contain sensors, logic and actuators. Anti-skid braking systems use sensors to control the brakes, while cruise control affects throttle position. A wide variety of services can be provided via communication links as the OnStar system. Autonomous cars (with exotic instrumentation) have been demonstrated.

2.3.3 Aircraft

Early aircraft had a few sensors[9]. "Steam gauges" converted air pressures into needle deflections that could be interpreted as altitude and airspeed. A magnetic compass provided a sense of direction. The displays to the pilot were as critical as the measurements.

A modern aircraft has a far more sophisticated suite of sensors and displays, which are embedded into avionics systems. The aircraft may contain inertial navigation systems, global positioning systems, weather radar, autopilots, and aircraft stabilization systems. Redundant sensors are used for reliability. A subset of the information may be transferred to a crash recorder to aid mishap investigations. Modern pilot displays now include computer displays including head-up displays.

Air traffic control radar is distributed instrumentation system. The ground portion transmits an electromagnetic pulse and receives an echo (at least). Aircraft carry transponders that transmit codes on reception of the pulse. The system displays aircraft map location, an identifier and optionally altitude. The map location is based on sensed antenna direction and sensed

time delay. The other information is embedded in the transponder transmission.

2.3.4 Laboratory Instrumentation

Among the possible uses of the term is a collection of laboratory test equipment controlled by a computer through an IEEE-488 bus (also known as GPIB for General Purpose Instrument Bus or HPIB for Hewlett Packard Instrument Bus). Laboratory equipment is available to measure many electrical and chemical quantities. Such a collection of equipment might be used to automate the testing of drinking water for pollutants.

2.4 Measurement Parameters

Instrumentation is used to measure many parameters (physical values). These parameters include:

Pressure, either differential or static, flow, temperature, levels of liquids, etc., density, viscosity, ionizing radiation, frequency, current, voltage, inductance, capacitance, resistivity, chemical composition, chemical properties, position, vibration, and weight.

2.5 Instrumentation Engineering

2.5.1 Introduction

Instrumentation engineering is the engineering specialization focused on the principle and operation of measuring instruments that are used in design and configuration of automated systems in areas such as electrical and pneumatic domains, and the control of quantities being measured. They typically work for industries with automated processes, such as chemical or manufacturing plants, with the goal of improving system productivity, reliability, safety, optimization and stability. To control the parameters in a process or in a particular system, devices such as microprocessors, microcontrollers or PLCs are used, but their ultimate aim is to control the parameters of a system.

Instrumentation engineering is loosely defined because the required tasks are very domain dependent. An expert in the biomedical instrumentation of laboratory rats has very different concerns than the expert in rocket instrumentation. Common concerns of both are the selection of appropriate sensors based on size, weight, cost, reliability, accuracy, longevity, environmental robustness and frequency response. Some sensors are literally fired in artillery shells. Others sense thermonuclear explosions until destroyed. Invariably sensor data must be recorded, transmitted or displayed. Recording rates and capacities vary enormously. Transmission can be trivial or can be clandestine, encrypted and low-power in the presence of jamming. Displays can be trivially simple or can require consultation with human factors experts. Control system design varies from trivial to a separate specialty.

Instrumentation engineers are responsible for integrating the sensors with the recorders, transmitters, displays or control systems, and producing the Piping and instrumentation diagram for the process. They may design or specify

installation, wiring and signal conditioning. They may be responsible for calibration, testing and maintenance of the system.

In a research environment it is common for subject matter experts to have substantial instrumentation system expertise. An astronomer knows the structure of the universe and a great deal about telescopes – optics, pointing and cameras (or other sensing elements). That often includes the hard-won knowledge of the operational procedures that provide the best results. For example, an astronomer is often knowledgeable of techniques to minimize temperature gradients that cause air turbulence within the telescope.

Instrumentation technologists, technicians and mechanics specialize in troubleshooting, repairing and maintaining instruments and instrumentation systems. Figure 4 below shows a control valve.



Figure 4 Control Valve

2.5.2 Typical Industrial Transmitter Signal Types

- Current loop (4 – 20 mA) – Electrical
- HART – Data signaling, often overlaid on a current loop
- Foundation Fieldbus – Data signaling
- Profibus – Data signaling

Figure 5 below shows the instrumentation part of a piping and instrumentation diagram which will be developed by an instrumentation engineer.

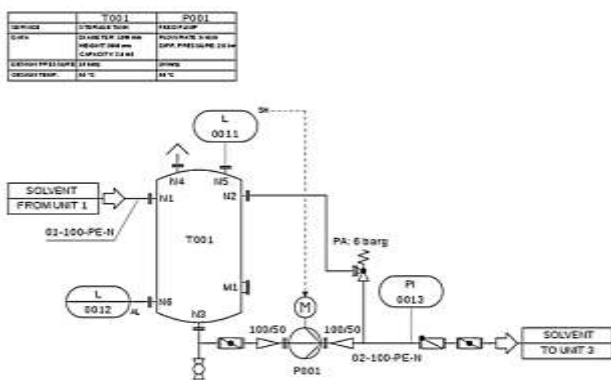

Figure 5 the Instrumentation Part of a Piping and Instrumentation Diagram

2.6 Impact of Modern Development

Ralph Müller (1940) stated, "That the history of physical science is largely the history of instruments and their intelligent use is well known. The broad generalizations and theories which have arisen from time to time have stood or fallen on the basis of accurate measurement, and in several instances new instruments have had to be devised for the purpose. There is little evidence to show that the mind of modern man is superior to that of the ancients. His tools are incomparably better." [10] and [11].

Davis Baird has argued that the major change associated with Floris Cohen's identification of a "fourth big scientific revolution" after World War II is the development of scientific instrumentation, not only in chemistry but across the sciences [11] and [12]. In chemistry, the introduction of new instrumentation in the 1940s was "nothing less than a scientific and technological revolution" [13] in which classical wet-and-dry methods of structural organic chemistry were discarded, and new areas of research opened up [13].

As early as 1954, W. A. Wildhack discussed both the productive and destructive potential inherent in process control [14]. The ability to make precise, verifiable and reproducible measurements of the natural world, at levels that were not previously observable, using scientific instrumentation, has "provided a different texture of the world" [15]. This instrumentation revolution fundamentally changes human abilities to monitor and respond, as is illustrated in the examples of DDT monitoring and the use of UV spectrophotometry and gas chromatography to monitor water pollutants [12] and [15].

III. CONTROL ENGINEERING

3.1 Introduction

Control engineering or control systems engineering is an engineering discipline that applies control theory to design equipment and systems with desired behaviors in control environments [3]. The discipline of controls overlaps and is usually taught along with electrical engineering and mechanical engineering at many institutions around the world [16].

The practice uses sensors and detectors to measure the output performance of the process being controlled; these measurements are used to provide corrective feedback helping to achieve the desired performance. Systems designed to perform without requiring human input are called automatic control systems (such as cruise control for regulating the speed of a car). Multi-disciplinary in nature, control systems engineering activities focus on implementation of control systems mainly derived by mathematical modeling of a diverse range of systems.

3.2 Overview

Modern day control engineering is a relatively new field of study that gained significant attention during the 20th century with the advancement of technology. It can be broadly defined



or classified as practical application of control theory. Control engineering plays an essential role in a wide range of control systems, from simple household washing machines to high-performance F-16 fighter aircraft. It seeks to understand physical systems, using mathematical modelling, in terms of inputs, outputs and various components with different behaviors; to use control system design tools to develop controllers for those systems; and to implement controllers in physical systems employing available technology. Systems can be mechanical, electrical, fluid, chemical, financial or biological, and its mathematical modelling, analysis and controller design uses control theory in one or many of the time, frequency and complex - s domains, depending on the nature of the design problem.

3.3 History

Automatic control systems were first developed over two thousand years ago. The first feedback control device on record is thought to be the ancient Ktesibios's water clock in Alexandria, Egypt around the third century B.C.E. It kept time by regulating the water level in a vessel and, therefore, the water flow from that vessel. This certainly was a successful device as water clocks of similar design were still being made in Baghdad when the Mongols captured the city in 1258 A.D. A variety of automatic devices have been used over the centuries to accomplish useful tasks or simply just to entertain. The latter includes the automata, popular in Europe in the 17th and 18th centuries, featuring dancing figures that would repeat the same task over and over again; these automata are examples of open-loop control. Milestones among feedback, or "closed-loop" automatic control devices, include the temperature regulator of a furnace attributed to Drebbel, circa 1620, and the centrifugal fly ball governor used for regulating the speed of steam engines by James Watt in 1788.

In his 1868 paper "On Governors", James Clerk Maxwell was able to explain instabilities exhibited by the fly ball governor using differential equations to describe the control system. This demonstrated the importance and usefulness of mathematical models and methods in understanding complex phenomena, and it signaled the beginning of mathematical control and systems theory. Elements of control theory had appeared earlier but not as dramatically and convincingly as in Maxwell's analysis.

Control theory made significant strides over the next century. New mathematical techniques, as well as advancements in electronic and computer technologies, made it possible to control significantly more complex dynamical systems than the original fly ball governor could stabilize. New mathematical techniques included developments in optimal control in the 1950s and 1960s followed by progress in stochastic, robust, adaptive, nonlinear control methods in the 1970s and 1980s. Applications of control methodology have helped to make possible space travel and communication

satellites, safer and more efficient aircraft, cleaner automobile engines, and cleaner and more efficient chemical processes.

Before it emerged as a unique discipline, control engineering was practiced as a part of mechanical engineering and control theory was studied as a part of electrical engineering since electrical circuits can often be easily described using control theory techniques. In the very first control relationships, a current output was represented by a voltage control input. However, not having adequate technology to implement electrical control systems, designers were left with the option of less efficient and slow responding mechanical systems. A very effective mechanical controller that is still widely used in some hydro plants is the governor. Later on, previous to modern power electronics, process control systems for industrial applications were devised by mechanical engineers using pneumatic and hydraulic control devices, many of which are still in use today.

3.4 Control Theory

There are two major divisions in control theory, namely, classical and modern, which have direct implications for the control engineering applications.

3.4.1 Classical SISO System Design

The scope of classical control theory is limited to single - input and single - output (SISO) system design, except when analyzing for disturbance rejection using a second input. The system analysis is carried out in the time domain using differential equations, in the complex-s domain with the Laplace transform, or in the frequency domain by transforming from the complex-s domain. Many systems may be assumed to have a second order and single variable system response in the time domain. A controller designed using classical theory often requires on-site tuning due to incorrect design approximations. Yet, due to the easier physical implementation of classical controller designs as compared to systems designed using modern control theory, these controllers are preferred in most industrial applications. The most common controllers designed using classical control theory are PID controllers. A less common implementation may include either or both a Lead or Lag filter. The ultimate end goal is to meet requirements typically provided in the time-domain called the step response, or at times in the frequency domain called the open-loop response. The step response characteristics applied in a specification are typically percent overshoot, settling time, etc. The open-loop response characteristics applied in a specification are typically Gain and Phase margin and bandwidth. These characteristics may be evaluated through simulation including a dynamic model of the system under control coupled with the compensation model.



3.4.2 Modern MIMO System Design

Modern control theory is carried out in the state space, and can deal with multiple-input and multiple-output (MIMO) systems. This overcomes the limitations of classical control theory in more sophisticated design problems, such as fighter aircraft control, with the limitation that no frequency domain analysis is possible. In modern design, a system is represented to the greatest advantage as a set of decoupled first order differential equations defined using state variables. Nonlinear, multivariable, adaptive and robust control theories come under this division. Matrix methods are significantly limited for MIMO systems where linear independence cannot be assured in the relationship between inputs and outputs. Being fairly new, modern control theory has many areas yet to be explored. Scholars like Rudolf E. Kalman and Aleksandr Lyapunov are well known among the people who have shaped modern control theory.

3.5 Control Systems

Control engineering is the engineering discipline that focuses on the modeling of a diverse range of dynamic systems (e.g. mechanical systems) and the design of controllers that will cause these systems to behave in the desired manner. Although such controllers need not be electrical, many are and hence control engineering is often viewed as a subfield of electrical engineering.

Electrical circuits, digital signal processors and microcontrollers can all be used to implement control systems. Control engineering has a wide range of applications from the flight and propulsion systems of commercial airliners to the cruise control present in many modern automobiles.

In most cases, control engineers utilize feedback when designing control systems. This is often accomplished using a PID controller system. For example, in an automobile with cruise control the vehicle's speed is continuously monitored and fed back to the system, which adjusts the motor's torque accordingly. Where there is regular feedback, control theory can be used to determine how the system responds to such feedback. In practically all such systems stability is important and control theory can help ensure stability is achieved.

Although feedback is an important aspect of control engineering, control engineers may also work on the control of systems without feedback. This is known as open loop control. A classic example of open loop control is a washing machine that runs through a pre-determined cycle without the use of sensors.

3.6 Control Engineering Education

At many universities around the world, control engineering courses are taught primarily in electrical engineering and mechanical engineering, but some courses can be instructed in mechatronics engineering[17], and aerospace engineering. In others, control engineering is connected to computer science, as most control techniques today are

implemented through computers, often as embedded systems (as in the automotive field). The field of control within chemical engineering is often known as process control. It deals primarily with the control of variables in a chemical process in a plant. It is taught as part of the undergraduate curriculum of any chemical engineering program and employs many of the same principles in control engineering. Other engineering disciplines also overlap with control engineering as it can be applied to any system for which a suitable model can be derived. However, specialized control engineering departments do exist, for example, the Department of Automatic Control and Systems Engineering at the University of Sheffield [18] and the Department of Robotics and Control Engineering at the United States Naval Academy[19].

Control engineering has diversified applications that include science, finance management, and even human behavior. Students of control engineering may start with a linear control system course dealing with the time and complex-s domain, which requires a thorough background in elementary mathematics and Laplace transform, called classical control theory. In linear control, the student does frequency and time domain analysis. Digital control and nonlinear control courses require Z transformation and algebra respectively, and could be said to complete a basic control education.

3.7 Control Engineering Careers

A control engineer's career starts with a bachelor's degree and can continue through the college process. Control engineer degrees are well paired with an electrical or mechanical engineering degree. Control engineers usually get jobs in technical managing where they typically lead interdisciplinary projects. There are many job opportunities in aerospace companies, manufacturing companies, automobile companies, power companies, and government agencies. Some places that hire Control Engineers include companies such as Rockwell Automation, NASA, Ford, and Goodrich [20]. Control Engineers can possibly earn \$66k annually from Lockheed Martin Corp. They can also earn up to \$96k annually from General Motors Corporation[21].

According to a Control Engineering survey, most of the people who answered were control engineers in various forms of their own career. There are not very many careers that are classified as "control engineer," most of them are specific careers that have a small semblance to the overarching career of control engineering. A majority of the control engineers that took the survey in 2019 are system or product designers, or even control or instrument engineers. Most of the jobs involve process engineering or production or even maintenance, they are some variation of control engineering [22].

3.8 Recent Advancement

Originally, control engineering was all about continuous systems. Development of computer control tools posed a



requirement of discrete control system engineering because the communications between the computer-based digital controller and the physical system are governed by a computer clock. The equivalent to Laplace transform in the discrete domain is the Z - transform. Today, many of the control systems are computer controlled and they consist of both digital and analog components.

Therefore, at the design stage either digital components are mapped into the continuous domain and the design is carried out in the continuous domain, or analog components are mapped into discrete domain and design is carried out there. The first of these two methods is more commonly encountered in practice because many industrial systems have many continuous systems components, including mechanical, fluid, biological and analog electrical components, with a few digital controllers.

Similarly, the design technique has progressed from paper-and-ruler based manual design to computer-aided design and now to computer-automated design or CAD which has been made possible by evolutionary computation. CAD can be applied not just to tuning a predefined control scheme, but also to controller structure optimization, system identification and invention of novel control systems, based purely upon a performance requirement, independent of any specific control scheme [23] and [24].

Resilient control systems extend the traditional focus of addressing only planned disturbances to frameworks and attempt to address multiple types of unexpected disturbance; in particular, adapting and transforming behaviors of the control system in response to malicious actors, abnormal failure modes, undesirable human action, etc.[25].

IV. CONCLUSIONS

Control systems engineering activities are multi-disciplinary in nature. They focus on the implementation of control systems, mainly derived by mathematical modeling. Because instrumentation and control play a significant role in gathering information from a system and changing its parameters, they are a key part of control loops.

High demand for engineering professionals is found in the fields associated with process automation and engineering systems control. Specializations include industrial instrumentation, system dynamics, process control, and control systems. Additionally, technological knowledge, particularly in computer systems, is essential to the job of an instrumentation and control engineer; important technology-related topics include human-computer interaction, programmable logic controllers, and SCADA. The tasks center on designing, developing, maintaining and managing control systems [2].

The goals of the work of an instrumentation and control engineer are to maximize productivity, optimization, stability, reliability, safety and continuity.

Many universities teach instrumentation and control engineering as an academic courses at the graduate and

postgraduate levels. It is possible to approach this field coming from many standard engineering backgrounds, being the most common among them Electrical and Mechanical Engineering, since these branches cover strong foundational subjects in control systems, system dynamics, electro-mechanical machines and devices, as well as electric circuits.

V. REFERENCES

- [1]. "Instrumentation ", The Northern Alberta Institute of Technology., Retrieved 17 October 2012.
- [2]. "Instrumentation and Control Engineering is for Perfectionists", Diksha P. Gupta.
- [3]. "Early Clocks". 2009-08-12. Retrieved 1 March 2012.
- [4]. "Building automation history page". Archived from the original on 8 July 2011. Retrieved 1 March 2012.
- [5]. Multhauf, Robert P. (1961), the Introduction of Self-Registering Meteorological Instruments, Washington, D.C.: Smithsonian Institution, pp.95–116 United States National Museum, Bulletin 228. Contributions from the Museum of History and Technology: Paper 23. Available from Project Gutenberg.
- [6]. Lynn, L.H. (1998). "The commercialization of the transistor radio in Japan: The functioning of an innovation community". *IEEE Transactions on Engineering Management*. 45 (3): 220–229. Doi: 10.1109/17.704244.
- [7]. Anderson, Norman A. (1998). *Instrumentation for Process Measurement and Control* (third edition). CRC Press. pp. 254–255. ISBN 978 - 0-8493-9871-1.
- [8]. Anderson, Norman A. (1998). *Instrumentation for Process Measurement and Control* (3 edition). CRC Press. pp. 8–ISBN 978-0-8493-9871-1.
- [9]. *Aircraft Instrumentation – Leroy R. Grumman Cadet Squadron*.
- [10]. Katz, Eric; Light, Andrew; Thompson, William (2002). *Controlling technology: contemporary issues* (2nd edition). Amherst, NY: Prometheus Books. ISBN 978-1573929837. Retrieved 9 March 2016.
- [11]. Baird, D. (1993). "Analytical chemistry and the 'big' scientific instrumentation revolution". *Annals of Science*. 50 (3): 267–290. Doi: 10.1080/00033799300200221. Download the pdf to read the full article.
- [12]. Baird, D. (2002). "Analytical chemistry and the 'big' scientific instrumentation revolution". In Morris, Peter J. T. (edition). *From classical to modern chemistry: the instrumental revolution; from a conference on the history of chemical instrumentation: "From the Test-tube to the Auto analyzer: the Development of Chemical Instrumentation in the Twentieth Century"*, London, in August 2000. Cambridge: Royal Society of



- Chemistry in assoc. with the Science Museum. pp. 29–56. ISBN 9780854044795.
- [13]. Reinhardt, Carsten, ed. (2001). *Chemical sciences in twentieth century* (1st edition). Weinheim: Wiley-VCH. ISBN 978-3527302710.
- [14]. Wildhack, W. A. (22 October 1954). "Instrumentation Revolution in Industry, Science, and Warfare". *Science*. 120 (3121): 15A. Bibcode:1954Sci...120A...15W. Doi: 10.1126/science.120.3121.15A. PMID 17816144.
- [15]. Hentschel, Klaus (2003). "The Instrumental Revolution in Chemistry (Review Essay)". *Foundations of Chemistry*. 5 (2): 179–183. Doi: 10.1023/A: 1023691917565.
- [16]. "Systems & Control Engineering FAQ | Electrical Engineering and Computer Science". Engineering.case.edu. Case Western Reserve University. 20 November 2015. Retrieved 27 June 2017.
- [17]. Zhang, Jianhua. *Mechatronics and Automation Engineering Second Ed.* Proceedings of the International Conference on Mechatronics and Automation Engineering (ICMAE2016). Xiamen, China, 2016.
- [18]. "ACSE - The University of Sheffield". Retrieved 17 March 2015.
- [19]. "WRC Home". USNA Weapons, Robotics and Control Engineering. Retrieved 19 November 2019.
- [20]. "Systems & Control Engineering FAQ | Computer and Data Science/Electrical, Computer and Systems Engineering". Engineering.case.edu. 2015-11-20. Retrieved 2019-10-30.
- [21]. "Control Systems Engineer Salary PayScale". WWW.payscale.com. Retrieved 2019-10-30.
- [22]. <https://www.controleng.com/wp-content/uploads/sites/2/2019/05/Control-Engineering-2019-Career-and-Salary-Study.pdf>.
- [23]. Tan, K.C. and Li, Y. (2001) Performance-based control system design automation via evolutionary computing. *Engineering Applications of Artificial Intelligence*, 14 (4). pp. 473 - 486. ISSN 0952-1976.
- [24]. Li, Y., et al. (2004). CACSD - Evolutionary search and optimization enabled computer automated control system design. *International Journal of Automation and Computing*, 1(1). PP.76-88. ISSN 1751-8520.
- [25]. C. G. Rieger, D. I. Gertman and M. A. McQueen, "Resilient control systems: Next generation design research," 2009 2nd Conference on Human System Interactions, Catania, 2009, pp. 632 - 636.

IJEAST

INTERNATIONAL JOURNAL
OF ENGINEERING APPLIED SCIENCE
AND TECHNOLOGY

ABOUT IJEAST

International Journal of Engineering Applied Science and Technology (IJEAST) is a peer-reviewed, open access journal that publishes high-quality research papers in the field of Engineering, Applied Science and Technology.

IJEAST aims to provide a platform for researchers, academicians, and professionals to share their innovative ideas, research findings, and practical experiences with the global scientific community.

FOCUS AREAS

- Engineering
- Applied Science
- Technology
- Innovation & Development
- Interdisciplinary Studies



PEER REVIEWED

All submissions are rigorously peer reviewed to ensure quality.



OPEN ACCESS

Free and unrestricted access to research for all.



GLOBAL REACH

Connecting researchers and professionals worldwide.



TIMELY PUBLICATION

We ensure a swift and efficient publication process.



For more information, visit our website
www.ijeast.com



INTERNATIONAL JOURNAL
OF ENGINEERING APPLIED SCIENCE
AND TECHNOLOGY

✉ editor@ijeast.com

🌐 www.ijeast.com

📍 India



2455-2143