



IJEAST

INTERNATIONAL JOURNAL
OF ENGINEERING APPLIED SCIENCE
AND TECHNOLOGY



VOLUME : 4 ISSUE : 07 Print / Issue Publication Date: 07-Jan-2020



ISSN : 2455-2143



DOI : 10.33564/IJEAST.2019.v04i07.054

Indexed In



WWW.IJEAST.COM

editor@ijeast.com

COMPUTER MOTHERBOARDS WITH ELECTRO-OPTICAL INTERCONNECTIONS

Jagrut Jadhav
Department of Electronics
Ramrao Adik Institute of Technology,
Mumbai, Maharashtra, India

Abstract— Implementation of copper traces in PCB can lead to interference and attenuation of signals. PCB is very vital part of any computer systems. The thickness of PCB depends on the layers of copper traces it used. This paper presents a novel approach of using an optical fiber instead of many copper paths on a PCB board for computers and other applications. Even though copper traces cannot be eliminated completely, they can only be used for supplying power to the board, computation and signal conversion from electrical to optical. This paper takes into account the signal conversion from electrical to optical will take internally inside processor and other photonic components like photonic IC.

Keywords— Fiber Optic Communications, Optical Transducers, Optical Multiplexers/D-multiplexers, High Speed Optical PCB, Photonic IC, On-board Optics

I. INTRODUCTION

In today's computer systems there have been many changes in terms of speed and power consumption. With increase in computer technology it can be predicted how future computers would look like. Even though we have electrons travelling through our circuits, the speed of electrons is much less compared to light (Khatimi et al.2018). Since light emit photons the interference and attenuation is very less in light. So new technology that can be integrated in computers processors and IC is photonic technology (Kish at al.2017). Photonic ICs are integrated circuits with photonics transistors which used light energy to switch on or off a transistor.

If photonic IC is manufactured, the power consumption of the mother board will be very less and hence efficient and faster computers can be developed. With SOC Photonic IC, the computation and calculation of the processor will be faster than today's transistorized processors. The output and inputs of the IC will be a photonic and powering of the IC will be electrical.

Therefore in electro-optical motherboard, signals will be transmitted using optical fiber and power supplied to photonic ICs will be electrical. This paper will contain only Optical PCB and not photonic IC research. It is assumed the IC used in PCB is photonic IC and not electronic IC.

II. DIFFERENCE IN COPPER AND FIBRE OPTIC DATA TRANSFER

Signal speed—

A signal are affected by the dielectric constant (E_r) of the PCB material travels with slow speed on a PCB transmission line. The relations for calculating the signal speed on a PCB are given below

$$\text{Signal speed on striplines: } V_{p(\text{inner})} \approx \frac{V_c}{\sqrt{E_r}} \approx \frac{11.8 \text{ in/ns}}{\sqrt{E_r}} \quad (1a)$$

$$\text{Signal speed on microstrips: } V_{p(\text{outer})} \approx \frac{V_c}{\sqrt{E_{r\text{eff}}}} \approx \frac{11.8 \text{ in/ns}}{\sqrt{E_{r\text{eff}}}} \quad (1b)$$

V_c is the velocity of light in vacuum or air
 E_r is the dielectric constant of the PCB material
 $E_{r\text{eff}}$ is the effective dielectric constant for microstrips and its value lies between 1 and E_r

E_r , and is approximately given by.

$$E_{r\text{eff}} \approx (0.64 E_r + 0.36) \quad (1c)$$

Propagation delay –

The propagation delay is the time taken by a signal to propagate over a unit length of the transmission line:

$$t_{pd} = \frac{1}{V} \quad (2a)$$

Where:

V is the signal speed in the transmission line

In vacuum or air, it equals 85 picoseconds/inch (ps/in).

At first propagation delay might not look large, But if we calculate delay time for transmission of light the it is less than electrical signals (Babani et al. 2014). Optical fiber cable work best under harsh environments in comparison with its metallic parts. It is not fragile or brittle, not heavy or bulky, less prone to electrical interference, more resistant to corrosion, and has a life expectancy of up to thirty years [4].

Signal Losses– The low signal attenuation performance and superior signal integrity found in fiber optical systems enables much longer runs for signal transmission than copper-based systems [5]. Attenuation are losses attributed to microscopic and macroscopic impurities in the fiber material, which cause scattering and absorption of the light signal. Attenuation is a function of the wavelength, and the loss is usually stated in dB/km [4]. Optical pulses traveling through fiber suffer very little attenuation because the fiber absorbs light only weakly. An optical signal still retains 50 % of its signal strength after traveling 12 km over a single mode fibers, independent of the data rate (-.25 dB/km) [6]. Others factors contributing in signal loss are dispersion, connectors, splices and bending effect.

III. OPTICAL PCB STRUCTURE

Recently the printed circuit board is only compatible with board to board optical communications for high data transmission (Schaes et al., 2012). But with this technology data can be transmitted chip to chip with different wavelength of lights. Below figure shows the basic structure of how optical PCB would look like.

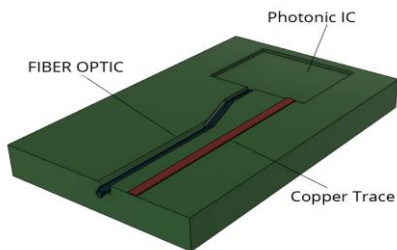

Figure 1: Optical PCB structure

The PCB contains multiple optical wave guide embedded in it. The outputs and inputs of the photonic IC will be directly connected to the optical fiber thus able to transmit and receive photonic signals. The upper bottom layer of the PCB will consist of copper traces to supply power to the system ICs and SOC. The MPO standard connectors are sufficient for connecting photonic IC transceiver to the PCB for successful communication between ICs.

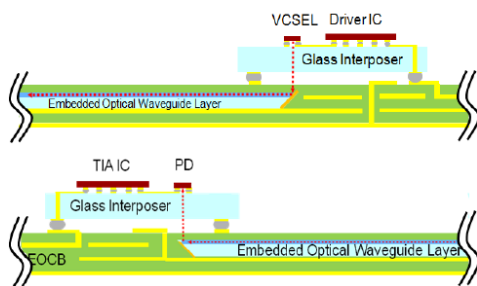

Figure 2

Current generation electrical switch IC supports 125 high speed lanes. The interface density may support 256 fiber optic cables. Now for multiple channel data transfer we need to use multimode fiber. For a computer system the address lines and the data lines are common which connects to corresponding memory components like RAM and ROM. The optical data transmission and reception may be easily possible by using multiplexing. Optical multiplexing is a method to merge different signals of different wavelength and the transmit it using one fiber. For this, multimode optical fiber is required to be embedded into the system. The following figure illustrate the data and address transmission using optical multiplexer.

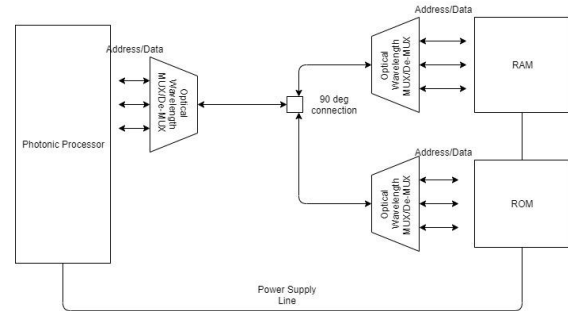

Figure 3: Multiple data transmission

As shown in diagram the 90 degree connector is used to divide the fiber into two different blocks. The 90 degree block is made from silica (Hwang, Park, Sae-Kyoung et al., 2006). The Fabrication of such PCB boards might cost more in the start but as the technology improves and more research is done in this field, the cost will eventually be affordable.

For Computers motherboards the fiber optic cables will be used only for transferring data from processor to different onboard components. The power supplied to the components will be electrical and will be distributed using copper traces connected to SMPS. The fiber cables embedded inside the PCB will be connected all the way from Northbridge and Southbridge to the PCI buses and input/outputs and ROMs. The data transmission will be taking place through fiber optics cables.

IV. INTERCONNECT SELECTION CONSIDERATIONS

The adoption of interconnect technology is always driven by usage model and the application. Many factors are involved in the selection of the best solution that meets all system requirements. One must consider major factors in the selection process to ensure optimized solution is possible for a target application. Today it is possible to develop transmitters and receivers with data rate of Gigabytes per seconds or even Terabyte per seconds. But maximum throughput of the device is limited to the power and the area that the device takes. These limitations can be solved using optical fibers which always give high throughput compared to electrical counterparts. As discussed earlier there is come propagation



delay and latency in transmitting data. The following data shows the delay in transmission in every temperature.

Temperature (°C)	Delay/Latency (ms)	
	Copper wire cable	Fiber Optic
22.77	13	3
23.33	13	3
23.88	13	3
24.44	13	3
25	12.95833333	3
25.55	13	3
26.11	13	3
26.66	13.95833333	4.239583333
27.22	14	4.791666667
28.33	14.56944444	5.430555556
28.88	14.1125	4.429292929
29.44	14.2962963	4.844017094
30	13.46722222	4.412563131
30.55	13.72988095	4.503695182
31.11	12.58333333	5.160714286
31.66	14.125	4.747596154
32.22	14.20833333	4.162037037

Figure 4

Change in air temperature affect increasing the value of delay which has effect of slowing down data transfer in both copper and optical fiber cable. So to consider a fiber operating at normal room temperature specific type of fiber should be used. It is deduced (Brushburg, Neukrish, Yadlowsky et al.2018) that an optical fiber made of glass is more reliable and efficient to use. Since glass has less thickness and high scalability in optical fiber, it is reliable to use in Optical PCBs. Optical sensors are sensitive to dirt particles that are stuck in between the connection points and degrade the optical coupling between fibers.

V. CONCLUSION

In this paper I have proposed a fiber optic technology embedded in PCB that can replace conventional method of tracing electrical copper paths on PCB. This technology will be efficient and reliable in computer systems as it will increase the operating speed and reduce power consumption. Implementing this technology will be easy and designing the PCB with guided holes and pin connections as per photonic IC is possible. Once such technology comes into existence, the speed of recent computers will be much less compared to futuristic fiber optic motherboard computers.

VI. ACKNOWLEDGEMENT

The Author is thankful to his parents for supporting him on this research paper. Moreover his sincere gratitude to his friends and college professors who directly or indirectly have lent their helping hand in this venture.

VII. REFERENCE

- [1] Kish Fred, Evans Peter, (2017)- "System-On-Chip Photonic Integrated Circuit", *JSTQE-INV-IPIP2018-06851-2017*.
- [2] Khatimi Hushnul, Setya Vijaya Eka, Sari Yuslena , (2018) ," Performance Comparison Between Copper Cables and Fiber Optic in Data Transfer on Banjarmasin Weather Temperature Conditions," MATEC Web of Conferences *ICSBE 2018*
- [3] Babani S., Bature A. A, Faruk M. I., Dankadai N. K., (2014), " COMPARATIVE STUDY BETWEEN FIBER OPTIC AND COPPER IN COMMUNICATION LINK", *International Journal of Technical Research and Applications, e-ISSN: 2320-8163*
- [4] Fiber Optical Networks Revealed, 2003 *RuggedCom Inc*,<http://www.ruggedcom.com>
- [5] The Benefits of Fiber Optics, Buddy Oliver, FiberPlex, Inc.2004, www.fiberplex.com.
- [6] Information in <http://www.kitco.com>
- [7] Schares L., Schow C., Doany F., Schuster C., Kash J., Kuchta D., Pepeljugoski P., Schaub J., Trehella J., Baks C., R. John, L. Shan, S. Hegde, Y. Kwark, D. Rogers, Libsch F., Budd R., Chiniwalla P., Rosner J., Tsang C., Patel C., Kucharski D., Guckenberger D., Dangel R., B. Offrein, M. Tan, G.Trott, M. Nystrom, A. Tandon, C.K. Lin, D. Dolfi, (2012) "Terabus – Awaveguide-based parallel optical interconnect for Tb/s classon-board data transfers in computer systems," *Proc. ECOC*,
- [8] Park Hyo-Hoon, Sung Hwan, Mu Hee Cho, Sae-Kyoung Kang, and Lee Tae-Woo,(2006)"Fusion of Fiber-Optic and PCB Technologies for In-board Optical Interconnection"Published in IEEE 2006 edition, 0-7803-9790-8
- [9] Brushburg Lars., Neukrish Ulrich, Yadlowsky Michael, (2018), "Onboard optical fiber and embedded waveguide interconnect" published in IEEE 2018 edition, 987-1-5386-6814-6
- [10] Kang S.-K., Lee T.-W., Plant D. V., and Park H.-H., (2006), "A Novel bidirectional CMOS transceiver for chip-to-chip optical interconnectws," *IEEE Photon. Technol. Lett.*, vol.18, no.1, pp. 70-72.
- [11] Cho H. S., Cho M. H., Rho B. S., Hwang S. H., and Park H.-H., (2005),"Passive optical components for chip-on-board type optical interconnection," *Proc. of SPIE*, vol. 5731, .pp.72-78, San Jose, USA, 2005.
- [12] Lemoff B. E. et al., (2004), "MAUI: Enabling Fiber-to-the-Processor With Parallel Multiwavelength Optical Interconnects" IEEE J. of Lightwave Technology, Vol. 22, No. 9 (2004), pp. 2043–2054.



- [13] Krisnamoorthy A.V. et al.,(2009), "*Computer Systems Based on Silicon Photonic Interconnects*", Proc. of the IEEE. Vol. 97, No. 7, Jul 2009. pp. 1337–1361.
- [14] OIF - Optical Internetworking Forum
- [15] Anritsu, "*Signal Integrity Analysis of 28 Gbit/s High-Speed Signals*", Application Note, May 2011

IJEAST

INTERNATIONAL JOURNAL
OF ENGINEERING APPLIED SCIENCE
AND TECHNOLOGY

ABOUT IJEAST

International Journal of Engineering Applied Science and Technology (IJEAST) is a peer-reviewed, open access journal that publishes high-quality research papers in the field of Engineering, Applied Science and Technology.

IJEAST aims to provide a platform for researchers, academicians, and professionals to share their innovative ideas, research findings, and practical experiences with the global scientific community.

FOCUS AREAS

- Engineering
- Applied Science
- Technology
- Innovation & Development
- Interdisciplinary Studies



PEER REVIEWED

All submissions are rigorously peer reviewed to ensure quality.



OPEN ACCESS

Free and unrestricted access to research for all.



GLOBAL REACH

Connecting researchers and professionals worldwide.



TIMELY PUBLICATION

We ensure a swift and efficient publication process.



For more information, visit our website

www.ijeast.com



INTERNATIONAL JOURNAL
OF ENGINEERING APPLIED SCIENCE
AND TECHNOLOGY

✉ editor@ijeast.com

🌐 www.ijeast.com

📍 India



2455-2143