



# IJEAST

INTERNATIONAL JOURNAL  
OF ENGINEERING APPLIED SCIENCE  
AND TECHNOLOGY



**VOLUME : 5    ISSUE : 4    Print / Issue Publication Date: 15-Oct-2020**



**ISSN : 2455-2143**



**DOI : 10.33564/IJEAST.2020.v05i04.072**

Indexed In



[WWW.IJEAST.COM](http://WWW.IJEAST.COM)

[editor@ijeast.com](mailto:editor@ijeast.com)

# PERFORMANCE ANALYSIS OF SOLAR PV- BATTERY GRID CONNECTED SINGLE PHASE TRANSFORMERLESS INVERTER

Kaviya.V

Department of EEE

Government College of Technology, India.

Maruthupandi.P

Department of EEE

Government College of Technology, India.

**Abstract**— Solar power efficiency is reduced by location and weather. To overcome this drawback, different renewable sources and converters are needed to be integrated with each other. In this paper, a grid tied solar PV system with energy storage is proposed. The aim is to provide continuous power supply for consumer by consuming the solar energy effectively. For this purpose, two components such as collector and a storage unit are required due to the nature of solar energy. BEMS helps to manage the situation by absorb it when excess energy is produced from PV panels and release it when the productivity drops by using Bidirectional converter. MPPT is used to obtain a maximum power tracking point. By Synchronous reference frame theory, the output from a transformerless inverter is connected to the grid. Simulation results are obtained from MATLAB/SIMULINK.

**Keywords**— Solar energy, battery storage system, MPPT, transformerless inverter, tied to grid.

## I. INTRODUCTION

In today's climate of growing energy needs and increasing environmental concern, alternatives to use of non renewable and polluting fossil fuels have to be investigated [1,2]. One such alternative is solar energy. It is one of the important sources due to its characteristic such as renewable, clean, eco-friendly during electricity production. Much of the world's required energy can be supplied directly by solar power. Integrating of renewable energy resources in existing system is going wild. The existing topology [3] is shown in fig 1. In this, dc power obtained from the PV array is stepped up by using converter [4]. Huusari *et al.* (2012) suggested that to meet the requirements for high-power applications, the converters are connected in series or in parallel [5]. Then inverter converts DC into AC to make it suitable for grid connection. A single-stage [6-8] or double-stage topology [9,10] is used. Barnes *et al.* (2012) have suggested that the efficiency of two-stage topology is higher than single-stage [11]. But expected efficiency is not obtained yet.

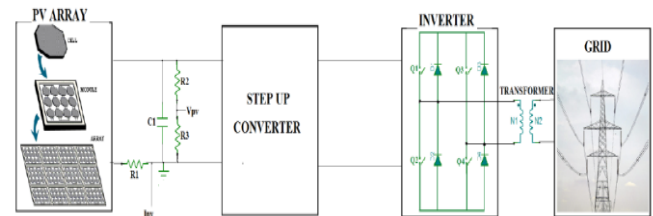

Fig.1.The equivalent circuit of a single-phase full bridge inverter with connected to grid.

Carrasco *et al.* (2006) stated the issue that solar energy output during the course of the day and year is not predictable. Reasons are clouds that pass over affect the solar power plants limit generation for short time, change in weather conditions and during night time [12,13]. This affects the efficiency of the solar power. To overcome this battery storage is included to have uninterrupted power supply.

## II. PROPOSED SYSTEM

### A. Description of a proposed system –

In this paper detailed modeling, control and simulation of a PV energy system that supply the load with battery backup are developed. Between battery storage and dc-link, a control algorithm is developed using bidirectional converter. LC filter is connected after the inverter to eliminate the high frequency harmonics.

A single phase transformerless inverter with vector control scheme is used to control the load side voltage in names of amplitude and frequency. The overall block diagram of the proposed system is shown in fig.2.

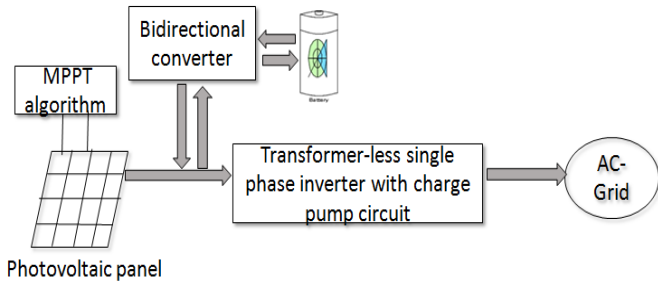

Fig.2. A proposed solar power system connected to the grid

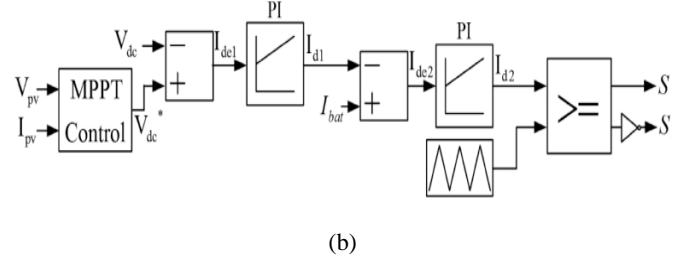

Fig.3. (a) bidirectional converter (b) control algorithm to maintain reference DC-link voltage

**B. Mpp algorithm –**

To maximize the power from the panels, MPPT is used by controlling the voltage and current optimal point. This power extraction control is required due to changes with solar radiation incident and panel temperature. The MPPT communicates with bidirectional converter for knowing whether the battery is charging or discharging. Its function is to control the output voltage by regulate the PWM duty cycle. There are different types of MPPT algorithm. Among these P&O algorithm is chose for its simple and efficient.

**C. Bidirectional converter –**

A charging to discharging and discharging to charging process is required in battery storage system. For this process to be take place bidirectional converter is used. This buck-boost is suitable for this operation because this topology requires minimal storage elements and two switching devices. This means less space ultimately less cost.

The bidirectional converter acts as boost converter, when  $V_{out}$  is higher than battery voltage or acts as a buck converter, when  $V_{out}$  is lower than battery voltage. If less power obtained from the solar panel means battery is discharged and if solar radiation is high means battery is charging by the control algorithm of bidirectional converter as shown in the fig.3. The two different operation modes are shown in fig.4 (a),(b). It achieves the best efficiency by using lower voltage power devices and operating current.

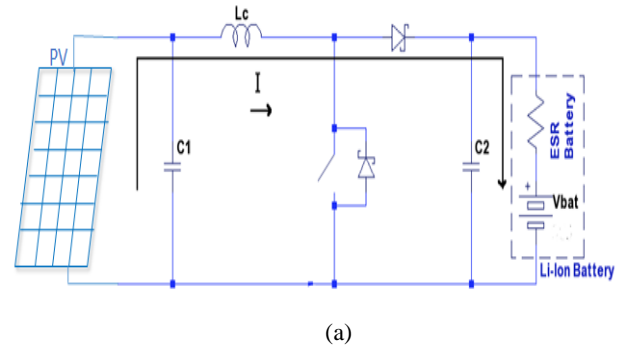

Fig.4. (a) Operation of Bidirectional converter in Boost mode

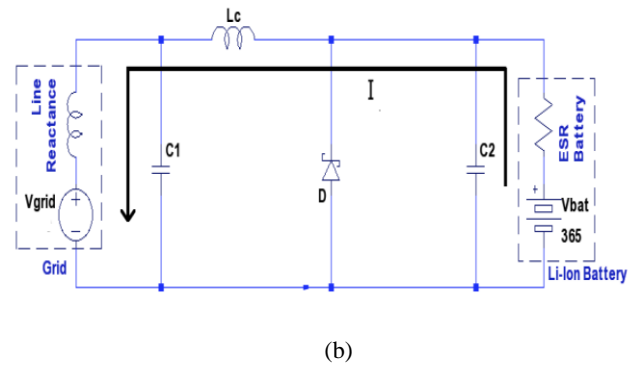
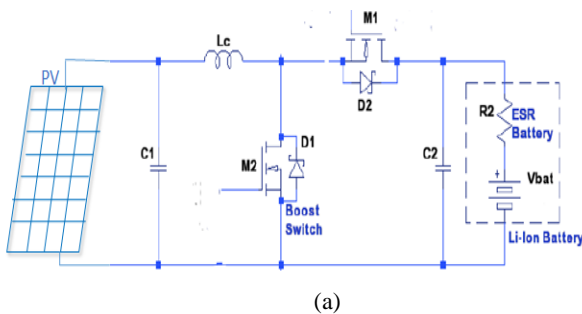

Fig.4. (b) Operation of Bidirectional converter in Buck mode

Table -2 Modes of bidirectional converter

| MODES | S1  | S2  | DESCRIPTION                                 |
|-------|-----|-----|---|
| Boost | On  | Off | Battery is charged.                         |
| Buck  | Off | On  | Battery is discharged by supply its energy. |



**D. Transformerless inverter –**

An inverter is necessary for any PV system involving a conversion between DC and AC power. The inverter selection, as with any other in the system, must be chosen carefully. Single phase transformerless inverter is used here. It consists of 4 MOSFET switches and 2 diodes as shown in fig. 6. This topology is chosen because it eliminates the leakage current by connecting the neutral of the grid to the negative terminal of the charge pump circuit. Diodes D1, D2 and capacitors C1, C2 connected across switches S3 and S4 to form charge pump circuit. Hence, the injection of dc into the grid is eliminated. This topology is also simple and easy to design.

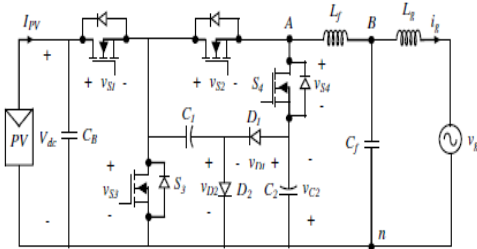

Fig.5. Single phase transformerless inverter

This topology is modulated by unipolar PWM. Four mode of operation that generate voltage state of +V<sub>dc</sub>, 0, -V<sub>dc</sub> is shown in table 2. Mode 1 conduction generates +V<sub>dc</sub>. Likewise, Mode 3 during negative cycle generates -V<sub>dc</sub> and Mode 2, Mode 4 for zero state.

Table -2 Modes of operation

| Modes | S1 | S2 | S3 | S4 | Output voltage  |
|-------|----|----|----|----|-----------------|
| 1     | 1  | 1  | 0  | 0  | +V <sub>d</sub> |
| 2     | 0  | 1  | 1  | 0  | 0               |
| 3     | 1  | 0  | 0  | 1  | -V <sub>d</sub> |
| 4     | 0  | 1  | 1  | 0  | 0               |

**E. Inverter control –**

The main aim is to generate sinusoidal reference grid currents, in order to operate the grid at unity power factor. Therefore, the inverter is controlled by using SRF theory, in order to generate reference grid currents. In the Synchronous reference frame, it converts grid voltage and grid current into frame that rotates synchronously with grid voltage vector by park transformation.

$$\begin{bmatrix} i_d \\ i_q \end{bmatrix} = \begin{bmatrix} \cos wt & \sin wt \\ -\sin wt & \cos wt \end{bmatrix} \begin{bmatrix} i_\alpha \\ i_\beta \end{bmatrix}$$

To obtain this, phase angle of grid voltage is detect by phase-locked loop. Now, steady state error is reduced by pi controller. Next d and q axes reference current are converted into  $\alpha, \beta$  using the below expression.

$$\begin{bmatrix} i_\alpha \\ i_\beta \end{bmatrix} = \begin{bmatrix} \cos wt & -\sin wt \\ \sin wt & \cos wt \end{bmatrix} \begin{bmatrix} i_d \\ i_q \end{bmatrix}$$

It needs a phase locked loop to generate synchronized sine and cosine signals, for  $\alpha, \beta$  to d-q reference frame transformation and for vice-versa.

**III. EXPERIMENT AND RESULT**

MATLAB 14a software platform is use to perform the experiment is shown in fig.6. The parameters are listed in table 3. The proposed scheme is simulated. From the simulation of the experiment results shown in fig.7(a),(b), we can draw to the conclusion that changes in solar panel power due to irradiance and temperature does not affect the inverter output due to the help of battery energy management.

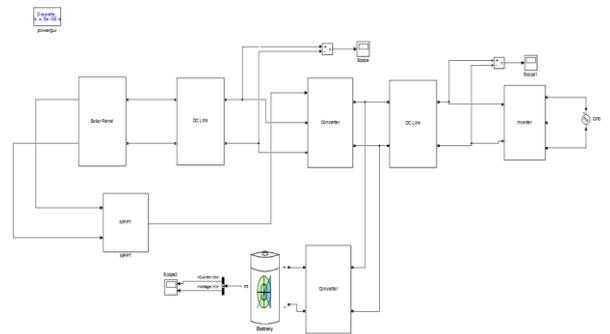
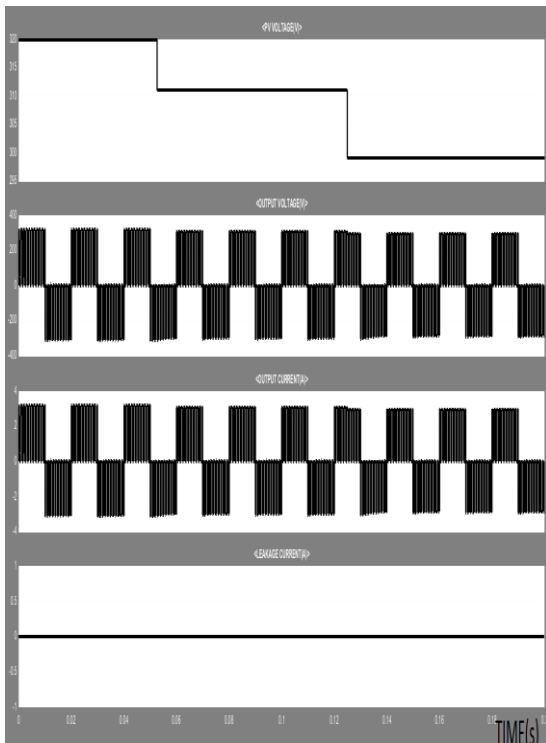

Fig.6. SIMULINK diagram of a proposed system

Table -3 Parameters of a proposed system

| PARAMETRERS         | RATING   |
|---------------------|----------|
| Input voltage       | 312V     |
| Grid voltage        | 220(rms) |
| Grid frequency      | 50Hz     |
| Rated power         | 5Kw      |
| AC output current   | 16A      |
| Switching frequency | 20kHz    |
| Lf                  | 6mH      |
| Cf                  | 13μF     |
| Lg                  | 3mH      |
| Battery voltage     | 440V     |
| Battery Ah          | 200Ah    |
| SOC                 | 40%      |



(a)

Fig.7. (a) PV voltage , output voltage of inverter without LC filter, output current without LC filter, leakage current.

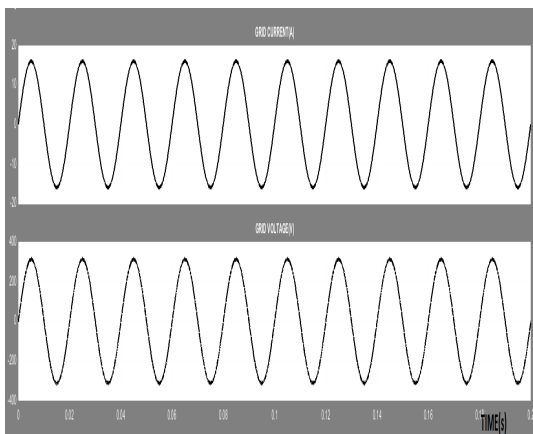

(b)

Fig.7. (b) Grid current, Grid voltage

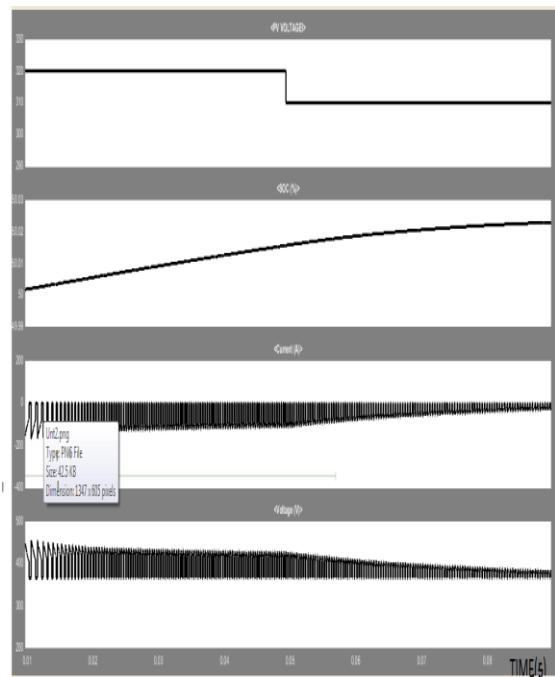

(a)

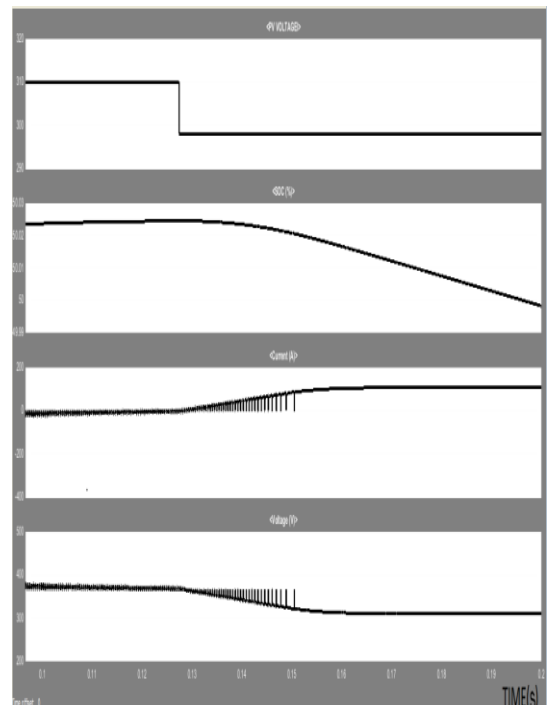

(b)

Fig.8. (a) show PV voltage, SOC, battery current, battery voltage while battery is charging. (b) show PV voltage, SOC, battery current, battery voltage while battery is discharging.

When the solar power is less than DC-link voltage, battery discharge and as well as charge if solar power is excess to maintain the required DC-link voltage is shown in fig. 8(a),(b).



#### IV. CONCLUSION

The varying nature of the solar power output decreases the efficiency of the system. This is over come by a storage unit called battery. At the same time, solar energy is utilized effectively.

Therefore, charging function of battery absorbs excess PV power and during reduced PV power discharging function provides continuous power supply to the grid by the bidirectional DC-DC converter. The leakage current is eliminated by charge pump circuit of transformerless inverter. By synchronous frame theory, the output from solar power generation is injected into the grid

A proposed design of single phase grid connected transformerless PV inverter system with energy storage is analyzed and simulated by using MATLAB/SIMULINK. This proves that continuous power supply to the grid irrespective of solar PV output.

Thus, this proposed configuration can greatly reduces the existing power demand by utilizing maximum of its energy, limits the use of conventional power generation techniques along with benefit of cost reduction from utility and also it is the only means to tackle the future power requirement.

#### V. ACKNOWLEDGEMENT

This work is supported by the Government college of technology, Coimbatore, Tamilnadu.

#### VI. REFERENCE

- [1] R. Batchu and M. P. Naran. (2015). Multi-stage scheduling for smart home with solar PV and battery energy storage, in Innovative Smart Grid Technologies - Asia (ISGT ASIA), IEEE, pp. 1–6.
- [2] Y. K. Wu, C. R. Chen, and H. A. Rahman. (2014). A novel hybrid model for short-term forecasting in PV power generation in International Journal of Photoenergy, vol. International Journal of Photoenergy, vol. 2014, Article ID 569249, 9 pages.
- [3] Hohm, D.P. Ropp. (2000). Comparative study of maximum power point tracking algorithms using an experimental, programmable, maximum power point tracking test bed in M.E.;Photovoltaic Specialists Conference, 2000. Conference Record of the Twenty-Eighth IEEE.
- [4] Rokade, S., Bandyopadhyay, B., Agarwal, V., *et al.* (2015). Control of single-stage grid-connected three-phase solar photovoltaic system using sliding mode control in Proc. IECON 2015 – 41st Annual Conf., Yokohama, pp. 3749–3754.
- [5] Huusari J., Suntio, T. (2012). Dynamic properties of current-fed quadratic fullbridge buck converter for distributed photovoltaic MPP-tracking systems in *IEEE Trans. Power Electron.*, 2012, **27**, pp. 4681–4689.
- [6] Libo, W., Zhengming, Z., Jianzheng, L. (2007). A single-stage three-phase gridconnected photovoltaic system with modified MPPT method and reactive power compensation in *IEEE Trans. Energy Convers.*, 2007, **22**, (4), pp. 881–886.
- [7] Jain, S., Agarwal, V. (2007). A single-stage grid connected inverter topology for solar PV systems with maximum power point tracking in *IEEE Trans. Power Electron.*, 2007, **22**, (5), pp. 1928–1940.
- [8] Rokade, S., Bandyopadhyay, B., Agarwal, V., *et al.* (2015). Control of single-stage grid-connected three-phase solar photovoltaic system using sliding mode control in Proc. IECON 2015 – 41st Annual Conf., Yokohama, pp. 3749–3754.
- [9] Sangwongwanich, A., Yang, Y., Blaabjerg, F. (2017). A sensorless power reserve control strategy for two-stage grid-connected PV systems in *IEEE Trans. Power Electron.*, 2017, **32**, (11), pp. 8559–8569.
- [10] Singh, B., Dwivedi, S., Hussain, I., *et al.* (2014). Grid integration of solar PV power generating system using QPLL based control algorithm in Proc. Sixth IEEE Power India Int. Conf. (PIICON), Delhi, 2014, pp. 1–6.
- [11] Barnes, K., Balda, J.C., Stewart, C.M. (2012). Selection of converter topologies for distributed energy resources in Proc. 27th Annual Applied Power Electronics Conf. Exposition (APEC), 5–9 February 2012, pp. 1418–1423.
- [12] Carrasco, J.M., Franquelo, L.G., Bialasiewicz, J.T., *et al.* (2006). Power-electronic systems for the grid integration of renewable energy sources: a survey in *IEEE Trans. Ind. Electron.*, 2006, **53**, (4), pp. 1002–1016.
- [13] Omran, W.A., Kazerani, M., Salama, M.M.A. (2011). Investigation of methods for reduction of power fluctuations generated from large grid-connected photovoltaic systems in *IEEE Trans. Energy Convers.*, 2011, **26**, (1), pp. 318–327.

# IJEAST

INTERNATIONAL JOURNAL  
OF ENGINEERING APPLIED SCIENCE  
AND TECHNOLOGY

## ABOUT IJEAST

International Journal of Engineering Applied Science and Technology (IJEAST) is a peer-reviewed, open access journal that publishes high-quality research papers in the field of Engineering, Applied Science and Technology.

IJEAST aims to provide a platform for researchers, academicians, and professionals to share their innovative ideas, research findings, and practical experiences with the global scientific community.

## FOCUS AREAS

- Engineering
- Applied Science
- Technology
- Innovation & Development
- Interdisciplinary Studies



### PEER REVIEWED

All submissions are rigorously peer reviewed to ensure quality.



### OPEN ACCESS

Free and unrestricted access to research for all.



### GLOBAL REACH

Connecting researchers and professionals worldwide.



### TIMELY PUBLICATION

We ensure a swift and efficient publication process.



For more information, visit our website  
[www.ijeast.com](http://www.ijeast.com)



INTERNATIONAL JOURNAL  
OF ENGINEERING APPLIED SCIENCE  
AND TECHNOLOGY

✉ [editor@ijeast.com](mailto:editor@ijeast.com)

🌐 [www.ijeast.com](http://www.ijeast.com)

📍 India



2455-2143