



# IJEAST

INTERNATIONAL JOURNAL  
OF ENGINEERING APPLIED SCIENCE  
AND TECHNOLOGY



**VOLUME : 6    ISSUE : 1    Print / Issue Publication Date: 08-Aug-2021**



**ISSN : 2455-2143**



**DOI : 10.33564/IJEAST.2021.v06i01.072**

Indexed In



[WWW.IJEAST.COM](http://WWW.IJEAST.COM)

[editor@ijeast.com](mailto:editor@ijeast.com)



# NON LINEAR CONTROL OF MULTIFED INDUCTION GENERATOR BASED OFFSHORE WIND TURBINE SYSTEM

Keerthana, Vahini, Sahana, Mohamed Rafi

Department of Electrical and Electronics Engineering  
Imayam College of Engineering, Kannanur

**Abstract**—Novel technique is used to improve the voltage ride of wind turbine system by using LVRT System. In most of the turbines sequence operation is a proper way to increase the capacity of electronic devices in PMDD wind power generation system. Direct Current Link are regulated in this system. Because it causes the ZSCC, which brings current oscillation, distortion of waveform, reduction in power, and interruption of Electromagnetic waves, and so on. This system gives a different methodology for offshore wind turbine system which are composed of the various control strategies applied to the multi-phase converter which can deal with mostly imbalanced. Apart from average models of the turbine system MVF is used to compensate highly imbalance load but not affecting the static and dynamic response of the system. Based on the above topology, the schematic diagram of the proposed system is constructed. The simulated results of offshore wind turbine system will show the advantages of the proposed system and control strategies.

**Key words** – Wind turbine system, Novel technique, Control strategies, Multi Variable Filter

## I. INTRODUCTION

Wind power has emerged to be one most viable renewable source of energy. From the growth of offshore wind turbine system, the rating of power wind turbine becomes large. In the PMDD wind power production system, full power converter is employed to connect generator to line. There is very hard to transfer the enormous amount of power to the bus by using one converter. To identify and minimize the problem, non linear control for double fed induction generator the parallel is

studied. In last few decades increase of main steam wind power has increased from 6MW in 1996 to 282.6GW in 2012. When the capability of offshore wind power turbine is steady and non-variance, the electronic devices with minimum rating can be used to decrease the cost of sequence operation. sequence operation makes kit design compact to minimize the generation time and increase the applications of module. The third order harmonics of total power can be decreases enhancelly by using carrier phase shift. The rating of filter can be reduced to decrease the generation cost.

Energy wastes that increase the carbon di oxide level in the surroundings, so it is the called "global warming". Wind energy is the new way of centralized electricity production. Harmonics can be eliminated through Control and Protection Switchgear or the various construction of various sides of power transformer to decrease the pollution effects to the line. vertical axis turbines are the main components of windmills. MPPT is available to track the speed of wind. Increases losses in power, decreases the efficiency of the system, and shortened the life of switching devices.

There are mostly two ways to reduce the Zero Sequence Circulating Current. This can be reduced by destroying the way of ZSCC. On the other side, it can be reduced by true control strategies. Isolation transformer is employed to destruct the route and eliminate the Zero Sequence Circulating Current. But the transformer works at the line frequency and its volume and weight are high, this may increases the production cost of energy. Hence, this topology is not suitable for the MW- level Permanant Magnet Direct Drive offshore wind turbine system. In this system with unique direct current buses is employed, which destruct the route and eliminates the Zero Sequence Circulating Current. But this methodology is only matched for generators

with separate windings. When the common multi-phase generator is employed, the problem of Zero Sequence Circulating Current is very large because the line-side Zero Sequence Circulating Current and the generator-side Zero Sequence Circulating Current are connected with one another. So the application of this field is limited. Furthermore, the disconnection of direct current buses increases the system size and is non convenient for hardware construction. In also, the two direct current bus voltages must be controlled, which requires more voltage and current sensors which makes the control system difficult. But this method of control strategy is more difficult to realize sequence operation with different modules. The Zero Sequence Circulating Current is suppressed by using null vector. But it requires to change the traditional space vector PWM (SVPWM) strategy, which turns it difficult to limit and achieve its application scope.

To reduce the above stated problems, this system proposes a new methodology for offshore wind power system. The MPPT method is employed to track the generator and compared with the grid power. According to the above research, the Zero Sequence Circulating Current controllers are designed, which depress the line-side Zero Sequence Circulating Current and the generator-side Zero Sequence Circulating Current effectively and do not enhance the module cost. The problems caused by Zero Sequence Circulating Current are current discrepancy, current waveform distortion, are overcomes and the efficiency and reliability of the topology are improved.

The proposed system of the offshore wind turbine system is shown. A suggested a compensative control strategy of LVRT enhancement for PMSG- based wind turbine when excessive power occurs during abnormal functions. The experimental and simulation results are verified by the theoretical as well as by MATLAB simulation.

## II. SYSTEM TOPOLOGY

The proposed system is shown in Fig. 1. Proposed topology is to introduce a PID adaptive control when the dedication of the framework is to balance the direct current link voltage against sag voltage.

The generator side converter is convert in ac to dc and grid side converter is convert from dc to ac supply. The PID control is used to stabilize the direct

current link voltage at constant to the rotor side converter.

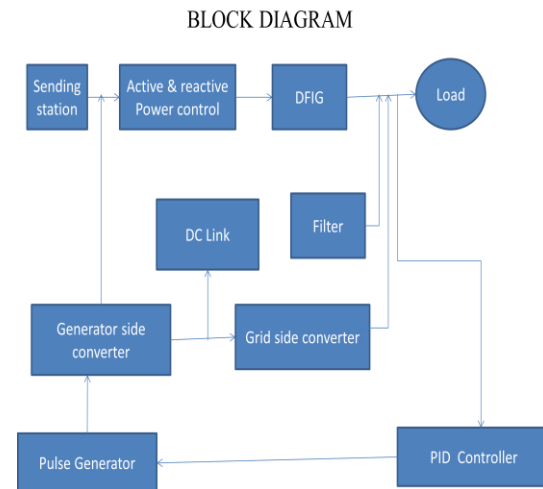

Fig 1 Block Diagram of offshore wind turbine system

Maximum power point tracking method is used to tracking the generator power. during voltage sags when the PID control to control in dc link voltage and meet LVRT by reducing the generator power.

Each converter is the back-to-back two-level voltage-source converter (VSC) and  $n$  converters with the same structures are

This study shows that the double fed induction generator is capable of fulfilling its role and providing the network with active power according to demand with good current quality, even in the case of an unbalanced load.

$C_k$  is the dc bus capacitor.  $L_{gk}$  is the three-phase inductance of generator-side, which has the function of filtering and avoiding the shortness of dc bus.  $L_{lk}$  ( $k = 1, 2, \dots, n$ ) is the three-phase inductance of line-side, which can filter the harmonic, store energy, and avoid the shortness of dc bus. Increasing the inductances can suppress the high-frequency components of the ZSCCs but cannot suppress the low-frequency components of the ZSCCs effectively. In addition, increasing inductances means the increment of volume, weight, and cost of the wind power converter. Therefore, the ZSCCs cannot be only suppressed by increasing the inductances.

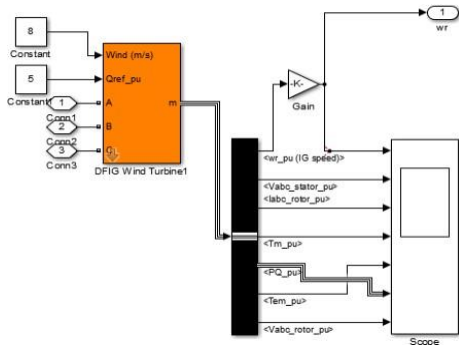

Fig 2 Model of the Wind turbine

Each converter is the second-level potential source converter and number of converters with the same structures. This study shows that the double fed induction generator which capable of complete its role and provide the system with active power based on the demand with good power quality, even in case of an imbalanced load.

### III. CONTROL STRATEGY

Fig. 3 shows the control scheme of the offshore doubly fed induction generator wind power and Fig. 6 is the rotor control scheme. The rotor angle position of the Permanent Magnet Side Generator  $\theta_g$  is obtained by using SMO, which has the more robust and enlarge the reliability of the system. Output of the system is given to all of the converters. The SMO is contained in the first generator-side controller. The  $k$ th generator-side controller has its own Zero Sequence Circulating Current controller which function is discussed next. Behalf of the SMO and the Zero Sequence Circulating Current controllers, the remaining parts of the generator side controller have no other differences, which are given as follows.

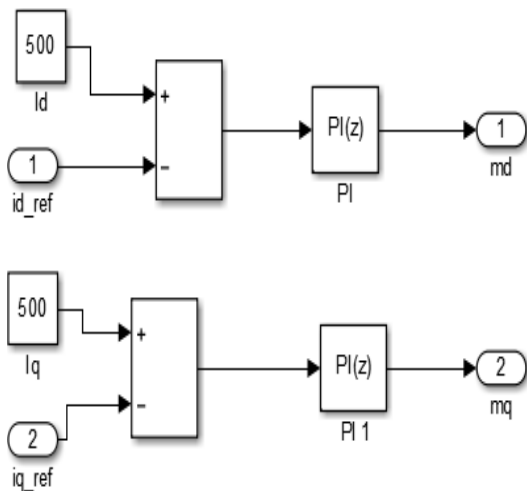

Fig 3 Current Control System of off shore wind turbine system

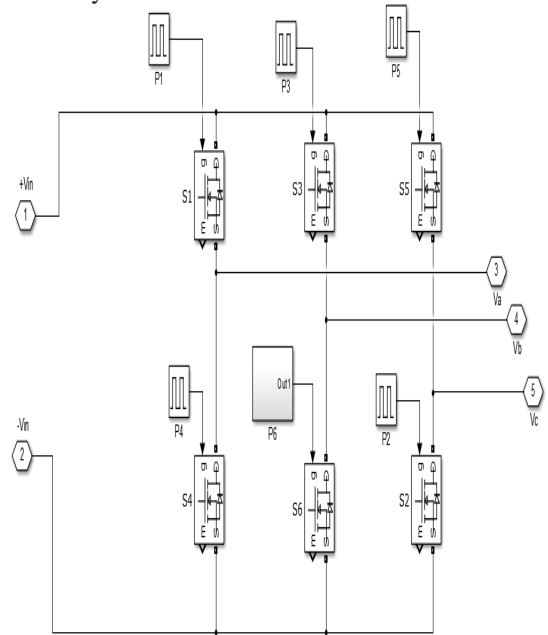

Fig 4 Control Scheme of Rotor Side Controller

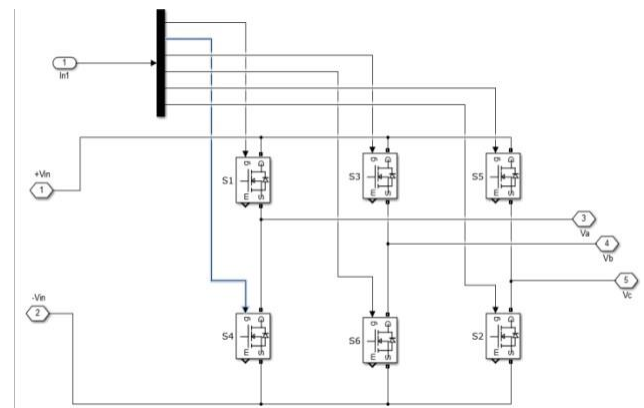

Fig 5 Control Strategy of Generator Side Converter

### IV. SIMULATION ANALYSIS

This proposed system gives the MATLAB simulation of two parallel converters to verify the parameters of the proposed system and various control scheme.  $n$  is assigned as two. It has been assigned by employing the simulation package The Permanent Magnet Side Generator operates at constant speed. The normal LL voltage of multi-phase grid is decreased to nominal voltage and the frequency of the grid is 50 Hz. The Pulse Width Modulation frequency is set to around 4.9 kHz. The capacitance value of the

two direct current capacitors are both around  $6799 \mu\text{F}$  and the voltage of the direct current bus is 451 V. To verify the characteristics of the parallel converters, some values are set manually. The inductance value of the two inductors are set as 2.1 mH and 1.8 mH, respectively. The inductances of the line-side are set at 4.2 mH and 3.9 mH, respectively. The dead-time of the generator and line side converters are  $2.13 \mu\text{s}$  and  $1.32 \mu\text{s}$ , respectively. Beside, the 24 Insulated Gate Bipolar Transistors used in the simulation have differences in resistance, voltage, tail time, and fall time.

Fig 6 Simulation Analysis of off shore wind turbinesystem

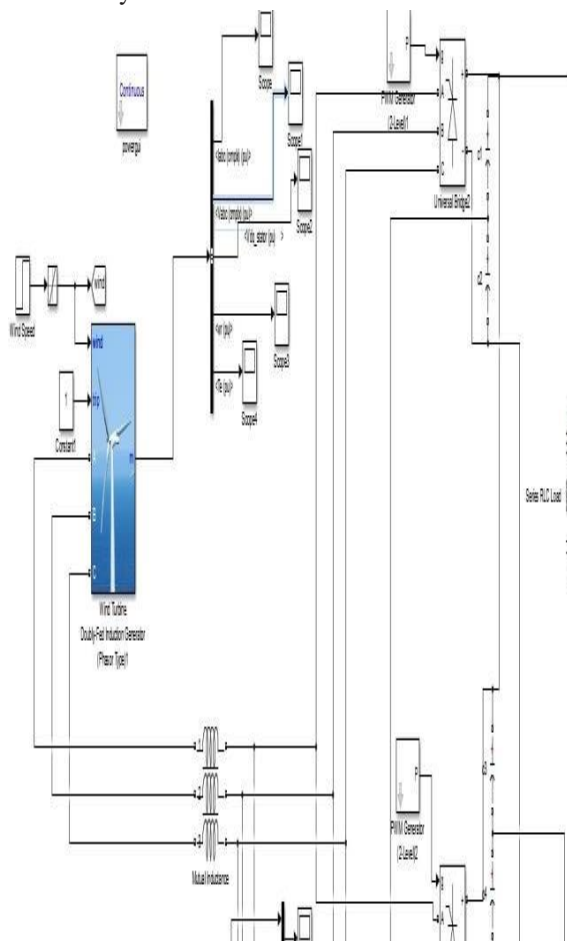

#### V. EXPERIMENTAL ANALYSIS

In addition to verify the past decades, the experiment has been conducted in a lab setup to verify the parameters of the system with the proposed methodology and the control schemes. The line-side converters and the generator-side converters are composed of two converters, respectively. In other words,  $n$  is valued to two. The characteristics of the Permanent Magnet Side Generator are identical with the one in the simulation that is given in Table I. Generator-side and line side converters are connected to the Permanent Magnet Side Generator through a multi-phase inductor. The inductance of the multilevel inductor is 2,1 mH and its accuracy is 9.8%. The capacitances of the two direct current capacitors are valued as  $6801 \mu\text{F}$  and the voltage value of the direct current bus is 451 V. The two converters are connected to the line through an inductor. The nominal inductance is 3.9 mH and its accuracy is  $\pm 9.9\%$ .

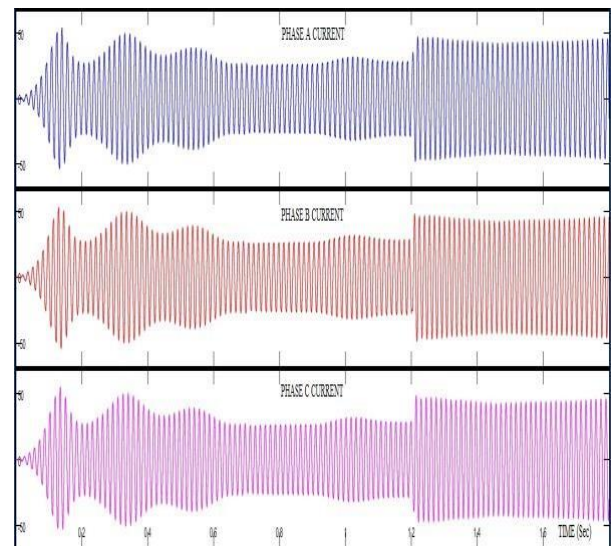

Fig 7 Output of phase current

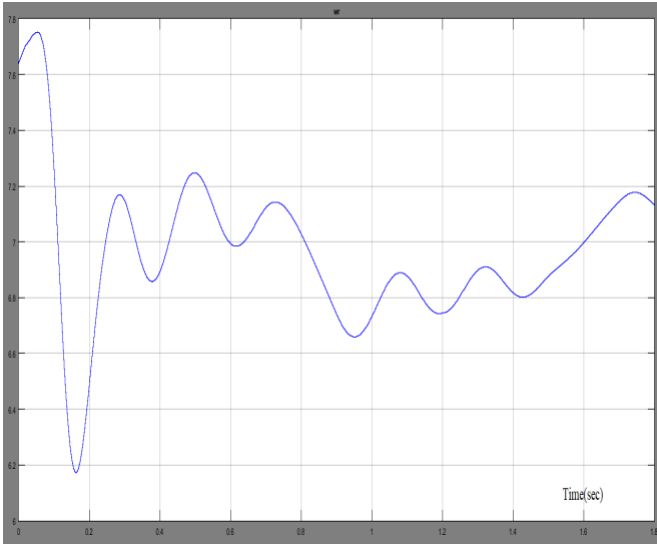

Fig 8 Output of wind turbine system

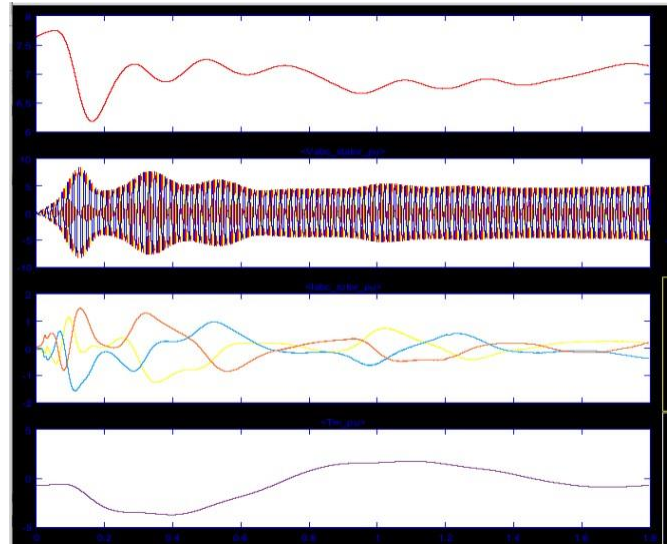

Fig 11 Output of Torque

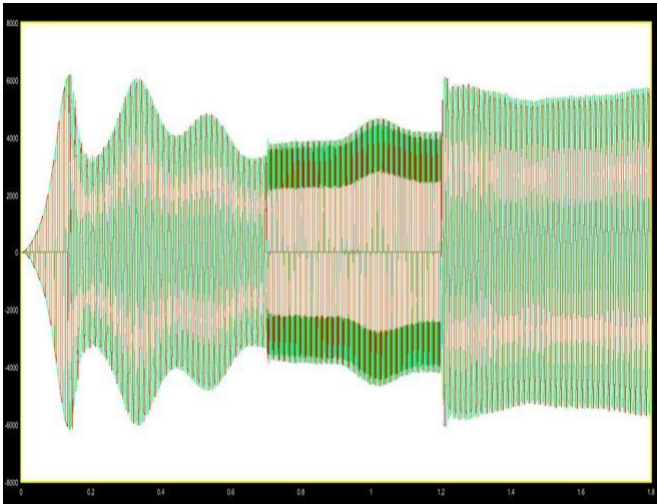

Fig 9 Output of DC Voltage system

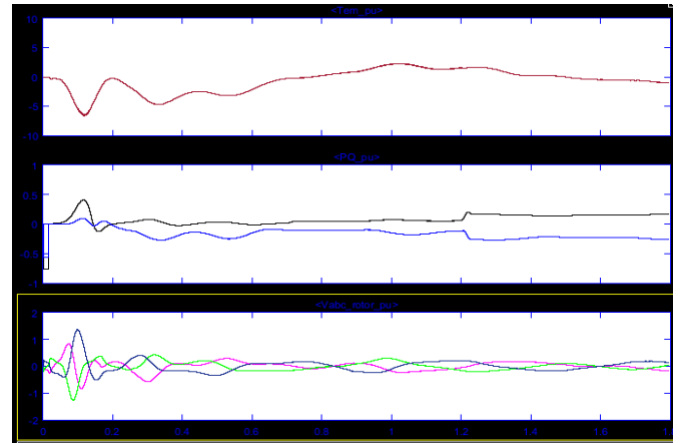

Fig 12 Output of Voltage

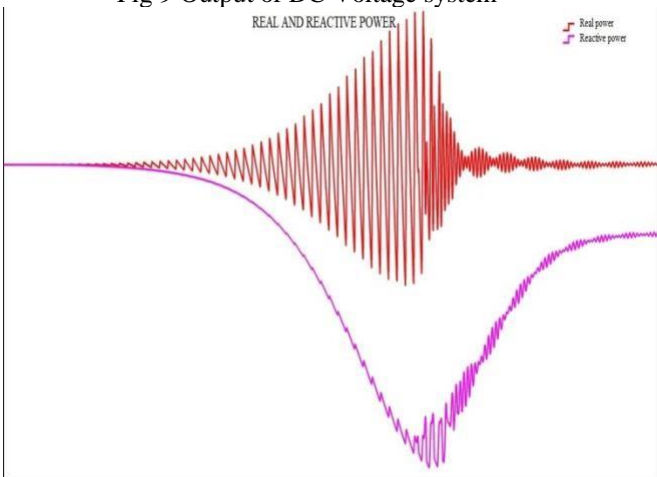

Fig 10 Output of Real and Reactive power

## VI. CONCLUSION

PMSG Non linear control unbalanced load not harmonic reduced minimum voltage produced. The proposed Zero Sequence Circulating Current controllers do not increase the module cost and they do not have no effect on the controlled variables. However, they may not modify the traditional SVPWM strategy, which turns them easier to expand and achieve their application scopes. They suppress the line-side Zero Sequence Circulating Currents and the generator-side Zero Sequence Circulating Currents effectively and the currents of converters are consistent and sinusoidal. The problems of asymmetry, current distortion, discrepancy, and are minimized well and the efficiency and reliability of the system are



increased. The output of this topology makes it possible to produce the wind power converters with maximum power rating. This paper studies the operation of non linear control of double fed induction generator based off shore wind turbine system. Reduced harmonics zero noise. high power produce better quality and high voltage.

#### VII. REFERENCES

[1] S. Li and T. A. Haskew, "Characteristic study of vector- controlled direct driven permanent magnet synchronous generator in wind power generation," in *Proc. Power Energy Soc. Gen. Meeting*, Pittsburgh, PA, 2008, pp. 1–9.

[2] S. Fukuda and K. Matsushita, "A control method for parallel-connected multiple inverter systems," in *Proc. Power Electron. Variable Speed Drive Conf.*, London, U.K., 1998, pp. 175–180.

[3] G. H. B. Foo and M. G. Rahman, "Direct torque control of an IPM-synchronous motor drive at very low speed using a sliding-mode stator flux observer," *IEEE Trans. Power Electron.*, vol. 25, no. 4, pp. 933–942, Apr. 2010.

[4] F. J. Lin, J. C. Hwang, P. H. Chou, and Y. C. Hung, "FPGA-based intelligent-complementary sliding-mode control for PMLSM servo-drive system," *IEEE Trans. Power Electron.*, vol. 25, no. 10, pp. 2573–2587, Oct. 2010.

[5] Z. Xu, P. Y. Ge, and D. G. Xu, "High performance control of a permanent magnet wind power generation system using an adaptive sliding observer," in *Proc. Power Electron. Drive Syst. Conf.*, Taipei, Taiwan, 2009, pp. 67–71.

[6] S. Z. Chen, N. C. Cheung, K. C. Wong, and J. Wu, "Integral sliding-mode direct torque control of doubly-fed induction generators under unbalanced grid voltage," *IEEE Trans. Energy Convers.*, vol. 25, no. 2, pp. 356–368, Jun. 2010.

[7] Z. Xu and M. F. Rahman, "An adaptive sliding stator flux observer for a direct-torque-controlled IPM

synchronous motor drive," *IEEE Trans. Ind. Electron.*, vol. 54, no. 5, pp. 2398–2406, Oct. 2007.

[8] T. P. Chen, "Circulating zero-sequence current control of parallel three-phase inverters," *Proc. Inst. Elect. Eng.—Elect. Power Appl.*, vol. 153, no. 2, pp. 282–288,

Mar. 2006.

[9] Y. Chen and K. M. Smedley, "One-cycle-controlled three-phase grid-connected inverters and their parallel operation," *IEEE Trans. Ind. Appl.*, vol. 44, no. 2, pp. 663–671, Mar./Apr. 2008.

[10] Z. H. Ye, D. Boroyevich, J. Y. Choi, and F. C. Lee, "Control of circulating current in two parallel three-phase boost rectifiers," *IEEE Trans. Power Electron.*, vol. 17, no. 5, pp. 609–615, Sep. 2002.

[11] S. K. Mazumder, "Continuous and discrete variable-structure controls for parallel three-phase boost rectifier," *IEEE Trans. Ind. Electron.*, vol. 52, no. 2, pp. 340–354, Apr. 2005.

[12] R. M. Cuzner, D. J. Nowak, A. Bendre, G. Oriti, and A.

L. Julian, "Mitigating circulating common-mode currents between parallel soft-switched drive systems," *IEEE Trans. Ind. Appl.*, vol. 43, no. 5, pp. 1284–1294, Sep./Oct. 2007.

[13] T. P. Chen, "Dual-modulator compensation technique for parallel inverters using space-vector modulation," *IEEE Trans. Ind. Electron.*, vol. 56, no. 8, pp. 3004–3012, Aug. 2009.

[14] F. S. Pai, J. M. Lin, and S. J. Huang, "Design of an inverter array for distributed generations with flexible capacity operations," *IEEE Trans. Ind. Electron.*, vol. 57, no. 12, pp. 3927–3934, Dec. 2010.

[15] R. Ramos, D. Biel, E. Fossas, and F. Guinjoan, "Interleaving quasi-sliding-mode control of parallel-connected buck-based inverters," *IEEE Trans. Ind. Electron.*, vol. 55, no. 11, pp. 3865–3873, Nov. 2008.

[16] J. Holtz, W. Lotzkat, and K. H. Werner, "A high-power multitransistor inverter uninterruptible power supply system," *IEEE Trans. Power Electron.*, vol. 3, no. 3, pp. 278–285, Jul. 1988.

[17] C. T. Pan, J. Y. Chang, C. M. Lai, Y. L. Juan, and Y. H. Liao, "Modeling of circulating currents for grid-connected parallel three-phase inverters," in *Proc. SICE Annu. Conf.*, Tokyo, Japan, 2008, pp. 1319–1322.

[18] L. L. Chen, L. Xiao, C. Y. Gong, and Y. G. Yan, "Circulating current's characteristics analysis and the control strategy of parallel system based on double close-loop controlled VSI," in *Proc. IEEE Power Electron. Spec. Conf.*, Aachen, Germany, 2004, pp. 4791–4797.

[19] Y. Chen and K. M. Smedley, "Parallel



- operation of one- cycle controlled three-phase PFC rectifiers,” *IEEE Trans. Ind. Electron.*, vol. 54, no. 6, pp. 3217–3224, Dec. 2007.
- [20] N. A. Rahim and J. Selvaraj, “Multistring five-level inverter with novel PWM control scheme for PV application,” *IEEE Trans. Ind. Electron.*, vol. 57, no. 6, pp. 2111–2123, Jun.2010.
- [21] W. Yao, M. Chen, J. Matas, J. M. Guerrero, and Z. M. Qian, “Design and analysis of the droop control method for parallel inverters considering the impact of the complex impedance on the power sharing,” *IEEE Trans. Ind. Electron.*, vol. 58, no. 2, pp. 576–588, Feb. 2011.
- [21] S. K. Mazumder, “A novel discrete control strategy for independent stabilization of parallel three-phase boost converters by combining space- vector modulation with variable-structure control,” *IEEE Trans. Power Electron.*, vol. 18, no. 4, pp. 1070–1083, Jul. 2003.
- [22] C. T. Pan and Y. H. Liao, “Modeling and coordinate control of circu- lating currents in parallel three-phase boost rectifiers,” *IEEE Trans. Ind. Electron.*, vol. 54, no. 2, pp. 825–838, Apr. 2007.
- [23] M. Jones, S. N. Vukosavic, and E. Levi, “Parallel- connected multiphase multidrive systems with single inverter supply,” *IEEE Trans. Ind. Elec- tron.*, vol. 56, no. 6, pp. 2047–2057, Jun. 2009.
- [24] K. Xing, F. C. Lee, D. Borojevic, Z. H. Ye, and S. Mazumder, “Interleaved PWM with discontinuous space- vector modulation,” *IEEE Trans. EnergyConvers.*, vol. 14, no. 5, pp. 906–917, Sep. 1999.
- [25] C. T. Pan and Y. H. Liao, “Modeling and control of circulating currents for parallel three-phase boost rectifiers with different load sharing,” *IEEE Trans. Ind. Electron.*, vol. 55, no. 7, pp. 2776–2785, Jul. 2008.
- [26] J. L. Li, Z. G. Gao, S. J. Hu, X. B. Fu, and H. H. Xu, “Applicationof parallel back-to-back PWM converter on the direct-drive wind power system,” *Autom. Elect. Power Syst.*, vol. 32, no. 5, pp. 59–62, Mar. 2008.

# IJEAST

INTERNATIONAL JOURNAL  
OF ENGINEERING APPLIED SCIENCE  
AND TECHNOLOGY

## ABOUT IJEAST

International Journal of Engineering Applied Science and Technology (IJEAST) is a peer-reviewed, open access journal that publishes high-quality research papers in the field of Engineering, Applied Science and Technology.

IJEAST aims to provide a platform for researchers, academicians, and professionals to share their innovative ideas, research findings, and practical experiences with the global scientific community.

## FOCUS AREAS

- Engineering
- Applied Science
- Technology
- Innovation & Development
- Interdisciplinary Studies



### PEER REVIEWED

All submissions are rigorously peer reviewed to ensure quality.



### OPEN ACCESS

Free and unrestricted access to research for all.



### GLOBAL REACH

Connecting researchers and professionals worldwide.



### TIMELY PUBLICATION

We ensure a swift and efficient publication process.



For more information, visit our website  
[www.ijeast.com](http://www.ijeast.com)



INTERNATIONAL JOURNAL  
OF ENGINEERING APPLIED SCIENCE  
AND TECHNOLOGY

✉ [editor@ijeast.com](mailto:editor@ijeast.com)

🌐 [www.ijeast.com](http://www.ijeast.com)

📍 India



2455-2143