



# IJEAST

INTERNATIONAL JOURNAL  
OF ENGINEERING APPLIED SCIENCE  
AND TECHNOLOGY



**VOLUME : 4    ISSUE : 05    Print / Issue Publication Date: 09-Nov-2019**



**ISSN : 2455-2143**



**DOI : 10.33564/IJEAST.2019.v04i05.067**

Indexed In



[WWW.IJEAST.COM](http://WWW.IJEAST.COM)

[editor@ijeast.com](mailto:editor@ijeast.com)



# DESIGN OF A FLIGHT CONTROLLER AND PERIPHERALS FOR A QUADCOPTER

Athanasios Sigalos  
Dept. of Industrial Design  
and Production  
Engineering,  
University of West Attica  
Athens, Greece

Michail Papoutsidakis  
Dept. of Industrial Design  
and Production  
Engineering,  
University of West Attica  
Athens, Greece

Avraam Chatzopoulos  
Dept. of Industrial Design  
and Production  
Engineering,  
University of West Attica  
Athens, Greece

Dimitrios Piromalis  
Dept. of Industrial Design  
and Production Engineering,  
University of West Attica  
Athens, Greece

**Abstract**— This paper will present the process of designing and implementing a controller that will be able to maintain control of a quadcopter. Although the market is now overwhelmed by such controllers, we wanted to design our own in order to give us the opportunity to apply, at practical level, the knowledge we gained during our studies. We start by giving a brief reference to the most important stations in the history of quadcopter as well as the various areas in which it excels. Then, we present the construction process of the quadcopter, giving an extensive description of the microcontroller, the sensors and the other peripherals used in our construction, including some information about the 3D object design program and the 3D printer we used in order to construct the body parts of the quadcopter. This will be followed by images of all the parts we have designed with their detailed description as well as pictures from all stages of our construction from the beginning to the completion. Finally, we present the method of operation of the quadcopter and we list the parts required for its typical operation, before making our conclusion comments.

**Keywords**—Quadcopter, microcontroller, sensors, 3D printer

## I. INTRODUCTION

There are a lot of air vehicles that give us the curiosity to study and understand how they work. One of these is the four-rotor helicopter known as quadrotor or quadcopter. Unlike common helicopters, where propellers change their pitch through a special mechanism, the quadrotors have fixed-pitch propellers like aircraft. Although the idea was innovative, many attempts had already been made in the past to create such aircraft and despite several successful efforts, the project was abandoned for several years until technology greatly reduced their size, weight and cost. Progress in the field of sensors, microcomputer technology, control and aerodynamic theory has made it possible to develop unmanned aircraft or else quadcopter. Quadcopters

are growing rapidly and have become widely known, in fact they have become a standardized research platform worldwide. The small size, low cost and flexibility of these systems has enabled them to be used in a variety of applications, such as exploration, rescue, and military use. They have also proven to be useful for exploring and 3D mapping the environment, as well as transporting, handling and assembling objects. A quadcopter is an unmanned multi-rotor helicopter with four arms each of which has a motor and a propeller at its ends. Unlike common helicopters where their control can change the pitch of the propellers in the quadcopters, the control is done by changing the angular velocity of the individual engines, using two pairs of identical propellers, two right-handed propellers (CW) and two left-handed propellers (CCW), where motion and lift can be controlled by the variation in the speed of each engine. This difference makes a quadcopter a simple construction but complicated with regard to the electronic control of each engine. The ability of the quadcopter to fly is entirely based on information about its position – angular position on three axes. This information is received by the sensors it consists of, usually of a gyroscope, an accelerometer and optionally a magnetometer.

## II. HISTORIC REVIEW

Quadcopters and drones have a very interesting story. The idea of a quadcopter had existed since the beginning of the 20th century. The first experimental attempts to build a rotating wing were made in 1907 by Jacques and Louis Breguet, two brothers from France, who built Gyroplane No 1 (Figure 1.1), but their design proved to be very unstable and therefore impractical.

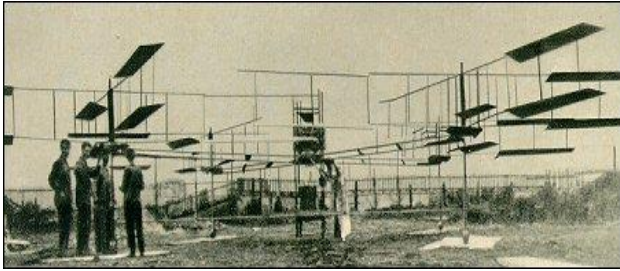

Fig. 1. Jacques and Louis Breguet Gyroplane No 1.

Then Etienne Oehmichen was the first scientist to experiment with a rotating wing in 1920. Among the six models he designed it was the second one that managed to take off successfully (Figure 1.2). This model was constructed from steel tubes on the ends of which the four double blade motors were based. He also placed five double blade motors laterally to ensure that it is stabilized. The aircraft had a significant degree of stability and was fully controllable and made more than a thousand test flights during 1920. Until 1923 it was able to stay for several minutes in the air and on April 14, 1924 it managed to travel a distance of 360 meters, thus defining a world record for an aircraft of this type at that time. Finally, after many pilot flights, it managed to complete a flight in a distance of 1 kilometer in 7 minutes.

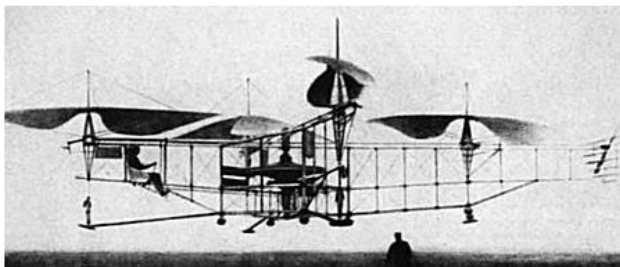

Fig. 2. Oehmichen No 2 Quadrotor.

After Oehmichen, engineers George de Bothezat and Ivan Jerome developed their own X-shaped aircraft (Figure 1.3), which consisted of four six-wing blades, and unlike that of Etienne Oehmichen they added wheels at the bottom in order to achieve smoother take off and landing. It made its first flight in October 1922 and until the end of 1923 it successfully completed 100 flights, with a maximum height of 5 meters.

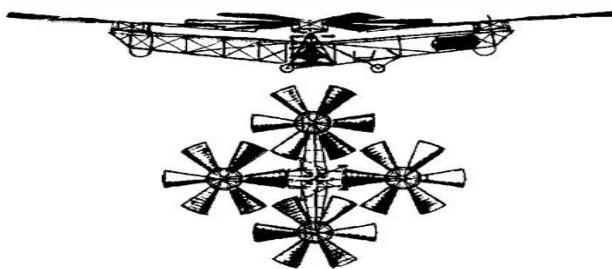

Fig. 3. George de Bothezat and Ivan Jerome Quadrotor.

Over the years there has been a significant improvement in the stabilization and control of quadcopters. In 1956, D. H. Kaplan had further refined his own aircraft (Figure 1.4) and demonstrated the ability to control the aircraft attitude using a different thrust between the engines. The aircraft incorporated four double blade motors and were mounted in an "H" like structure. The control mechanism was extremely simplified, it was not necessary to have a tail motor and the control was achieved by differential thrust change between the engines. It successfully made several flights and was the first quad-rotor aircraft to perform forward movement. However, due to the lack of orders for commercial or military use, the project was terminated.



Fig. 4. D. H. Kaplan model A Quadrotor

### III. DESIGNING AND CONSTRUCTING THE QUADCOPTER

When constructing a quadcopter we have to take into consideration the frame that we will use because on top of it we will install the engines, the battery and the control board of the various peripherals. There are two factors that must be taken into account when choosing the material for its construction, the weight of the construction, as the final construction must be as light as possible, and its durability on the applied forces. We decided to use a 3D printer in order to construct the quadcopter's frame. First of all we had to design the parts from which our framework will consist – for this part we used the designing program AutoCAD 123D Design. AutoCAD 123D Design is one of the most popular AutoCAD design programs. It is a complete set of two-dimensional and three-dimensional illustration that helps all stages of the designing process, including drawings, topographic analysis, design, photorealism and model presentation. Its main advantage over other similar tools is that it is designed with regard to the beginner user, with a friendly user interface, including tips and suggestions in every step.

#### A. Frame parts

Below we will present the sections we designed, including images for each individual segment. The parts of the construction are:

- Bottom frame: The bottom of the frame (Figure 3.1) is designed to provide easy fitting of various components. Left and right on the frame, two special positions are designed in

which we can easily place the two ESCs. In the lower left corner we have created a special position for the ultrasonic sensor as well as a position for the battery.

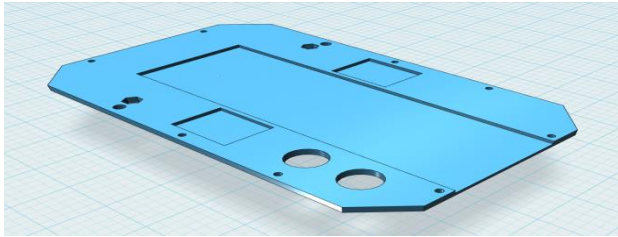

Fig. 5. Bottom frame

- Inner part (A): In this part (Figure 3.2) we also have two, left and right, positions where the other two ESCs will be placed. In addition we have created a special space on the back where two more ultrasound sensors could be placed. Finally we have left two open passes so that we can easily pass the lower level cables. As we can see, the inside of it is completely empty because the battery will pass through.

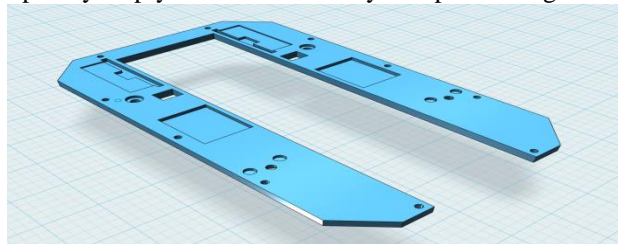

Fig. 6. Inner part (A)

- Inner part (B): This part (Figure 3.3) also includes the same bases with the previous part that help to correctly position the sensors of the upper part as well as the two open passages to pass the cables from the other two previous parts. In the middle, we observe a kind of channel as the battery will pass from there. rotated by 180 °.

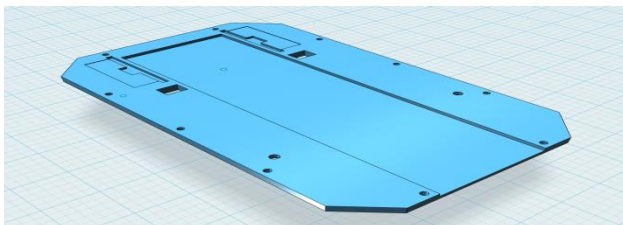

Fig. 7. Inner part (B) (rotated by 180 °)

- Top frame: In the upper part (Figure 3.4) we can see that the designed positions are rather different from the other parts and this is because most of the peripherals will be installed on it. At the two rear ends there are designed seats for the GPS units, two special spaces to put the radio transceiver and the

receiver of our remote control. Finally, there are places for the installation of the ultrasound sensors in the right, back and front sides.

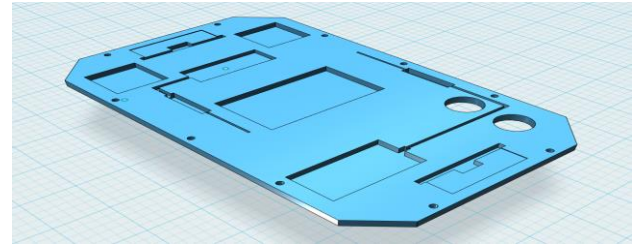

Fig. 8. Top frame

- Motor mount: Dc brushless motors will be mounted on the supports (Figure 3.5). At the front there is a space designed to fit an RGB LED and on the center there is a groove in which the cables will be passed. On the back there is a special socket into which we will place an aluminum rod. Finally, all necessary holes are provided through which the screws for supporting the motors as well as the rod will be passed.

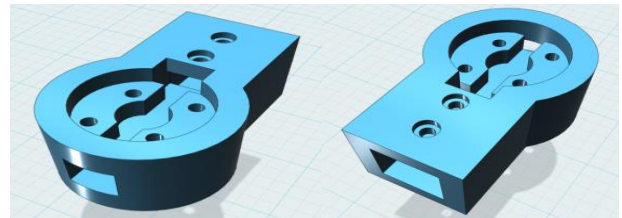

Fig. 9. Motor mount

- Arm coupling: The body coupling (Figure 3.6) is the one that will connect the motor to the main body of the chassis. Throughout its interior there is a continuous channel through which the motor wiring and the RGB LED will pass. Finally, its front part has been reinforced by designing two inner bases on which the aluminum bar will rest on, ensuring durability, stiffness and perfect support.

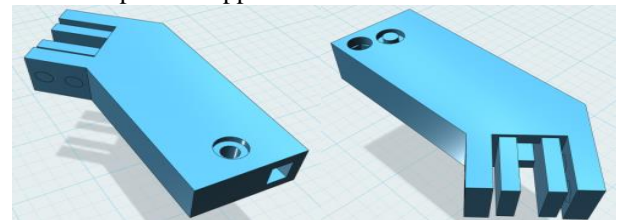

Fig. 10. Arm coupling

### **B. 3D printing the frame parts**

3D printing is an advanced technology, or better a process, that makes possible to create objects through the prosthetic method in which objects are made by sequentially adding layers of material. Two are the main categories of 3D printers,

FDM (Fused Deposition Modeling) technology and DLP / SLA (Digital Light Processing / Laser-based Stereolithography). 3D FDM technology printers rely on the melting and selective deposition of a thin thermoplastic fiber for the formation of successive layers that will create the final object. The objects produced are quite durable and usually ready to use without requiring any additional processing. Their main disadvantage is that they are lagging behind in the formation of very fine features. The raw material used by such a printer is a 1.75 or 2.85 centimeter thermoplastic yarn, produced in many categories with the best known PLA and ABS as they can be used in a wide range of applications. 3D DLP / SLA printers use stereolithography technology, which is achieved through light-thinning photopolymerisation specially designed for 3D printing of liquid resins. These resins have the property of being solidified when exposed to ultraviolet radiation, thus taking shape and incorporating each layer on top of each other, forming the natural copy of the digital 3D model. Objects produced by such a type of printer are of superior quality, precision and detail. They use special resins as raw material where depending on their type they confer on the final product specific properties and features such as casting and increased strength. Below we present the illustrations of the printed parts as well as the entire assembly of the parts.



Fig. 11. Printed parts of the Quadcopter



Fig. 12. The Quadcopter fully assembled

#### IV. SUMMARY OF ALL PARTS AND COMPONENTS

In the following paragraphs we will list the components and all special parts that we used in order to construct our quadcopter.

#### A. Microcontroller MK66FX1M0VLQ18

Trade is flooded by hundreds of development platforms each with its own capabilities. Considering that the microcontroller will be the heart of our project, we have paid particular attention to features such as connectivity, availability of I / O pins, and the required power. The microcontroller we decided to use in our project was the MK66FX1M0VLQ18, its technical specifications are given below:

Table -1 MK66FX1M0VLQ18 specifications

|                      |                                     |
|----------------------|-------------------------------------|
| Supply voltage       | 1.71V - 3.6V                        |
| Processor            | 180 MHz ARM Cortex-M4 with FPU      |
| Flash                | 1M                                  |
| Ram                  | 256K                                |
| EEPROM               | 4K                                  |
| I/O Pins             | 62                                  |
| Analog Inputs        | 25 (2 ADCs with 13 bits resolution) |
| Analog Outputs       | 2 (with 12 bit resolution)          |
| PWM Outputs          | 22                                  |
| DMA Channels         | 32                                  |
| Serial Ports         | 6 (2 with FIFO & Fast Baud Rates)   |
| SPI Ports            | 3 (1 with FIFO)                     |
| I2C Ports            | 4                                   |
| CAN Bus Ports        | 2                                   |
| SD Card Port         | 1 Native (4 bit SDIO)               |
| USB Port             | 1 (High Speed (480 Mbit/sec))       |
| Hardware Timers      | 14                                  |
| CRC Compilation Unit | Yes                                 |

It has all the features we needed to develop our own quadcopter. This one is not marketed as an integrated development platform, so we had to design it based on our own requirements. For our design we used the PCB eagle design software, an electronic circuit design software with printed circuit board (PCB), router and CAM production features. It also includes a 3D viewer that we can use to inspect our design on an interactive canvas. The board we designed, due to its complexity, had to be extracted in two layers.

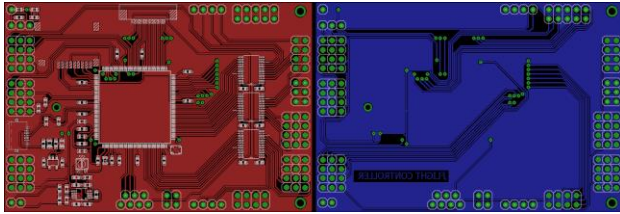

Fig. 13. Flight Controller PCB layout, 1 layer (red) - 2 layer (blue)

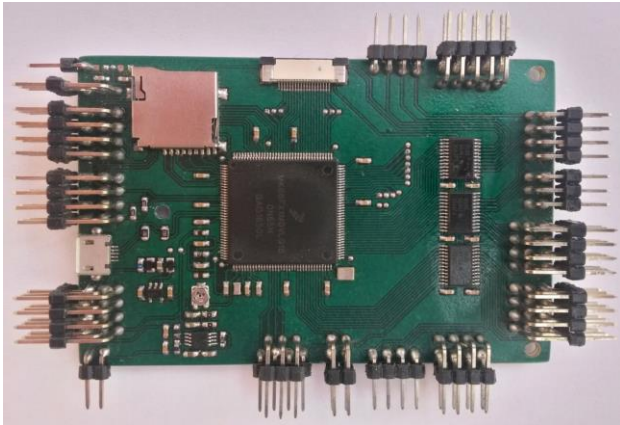

Fig. 14. Installed PCB Flight Controller

### B. Inertial Measurement Unit (IMU)

An Inertial Measurement Unit is an electronic device that detects the current acceleration rate, angular velocity and magnetic field changes, using a combination of gyroscope and magnetometer accelerometers. Although there are several such units in trade, we have designed our own, enabling us to shape it as we want for our trials. Its design was made with the PCB eagle design software and it had to be done in two layers.

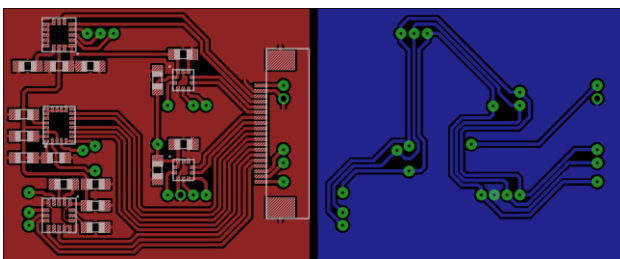

Fig. 15. IMU PCB layout, 1 layer (red) - 2 layer (blue)

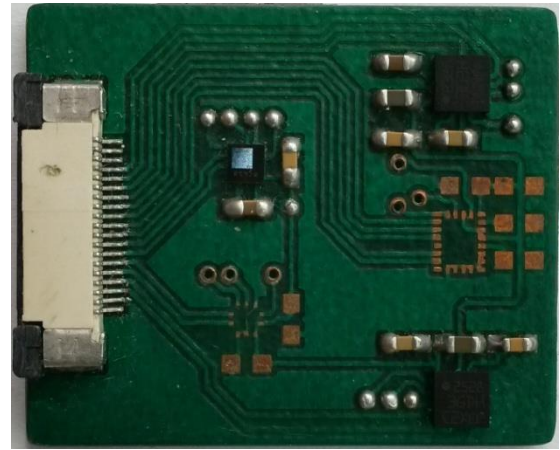

Fig. 16. Installed PCB IMU

### C. Gyroscope

A gyro sensor detects the angular velocity on three axes, so it can detect the shift angle on X (ROLL), Y (PITCH) and Z (YAW) respectively. The sensor we selected is the L3GD20H of STMicroelectronics (Figure 4.5), a 3-axis angular speed sensor with standard I2C / SPI serial interface output. The device has a full  $\pm 245 / \pm 500 / \pm 2000$  dps range and is capable of detecting changes in a bandwidth selected by the user. It also has a complete 32-position "first in – first out" (FIFO) controller that allows the user to store the data to limit the CPU intervention and two interrupt outputs that can be configured to produce stop signals. Finally it operates on an extended voltage range between 2.2 V - 3.6V with a low 5mA current.

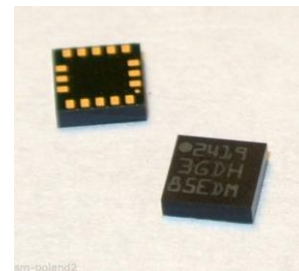

Fig. 17. Angle speed sensor L3GD20H

### D. Accelerometer – magnetometer

The acceleration sensor allows us to measure the accelerating force that a body receives on the three axes X, Y and Z, whereas our magnetometer provides magnetic field strength data. We used the STMicroelectronics LSM303D sensor (Figure 4.6), which has an accelerometer and a three-axis magnetometer. It includes an I2C serial bus that supports standard and fast operation as well as a SPI serial communication contact. It has a full linear acceleration range

of  $\pm 2 / \pm 4 / \pm 6 / \pm 8 / \pm 16$  g and a magnetic field range of  $\pm 2 / \pm 4 / \pm 8 / \pm 12$  gauss. It integrates a "first in - first Out" (FIFO) controller for each of the three output channels, saving energy as the continuous interference of the central processing is limited. It can still be set to produce stop signals from both outputs. It operates in a voltage range of 2.16 V - 3.6V with a consumption of 300 $\mu$ A.



Fig. 18. Accelerator - Magnetic field sensor LSM303D

### E. Brushless DC motors

A motor converts the supplied electric energy into mechanical. Brushless DC motors are synchronous direct current driven motors. They differ from conventional brushed dc motors because the switching of the input voltage applied to their armature takes place electronically and not with mechanical switches or carbon brushes. The electromagnets do not move, instead the permanent magnets are rotated and the armature stays static. These engines have many advantages such as their lack of collector that makes them reliable, they deliver a great torque even from the start (but they absorb high current), they produce low electric noise and can reach very high speeds yielding satisfactory torque. Finally they are divided into two categories: outrunner and inrunner. Outrunners have a higher torque at lower revs and are recommended to use for direct load without using a gearbox. Brushless motors are characterized by a constant called KV. It is the engine speed constant measured in RPM per Volt. This constant determines the maximum engine speed in no-load conditions. For example a motor with a KV = 750 if a 16V voltage is applied will rotate with  $750KV * 16V = 12000RPM$ .



Fig. 19. Brushless DC motor RCTIMER 5010

### F. ESC (Electronic Speed Controller)

An ESC is an electronic circuit that controls and regulates the speed of an electric motor, it can change its direction as well as act as a dynamic brake. In fact, an electronic speed controller drives an electric motor according to the PWM signal it receives at a given time, thus determining the speed at which it should rotate. Many ESCs incorporate a circuit design that allows us to provide electrical power to other circuits without the need for multiple batteries, this circuit is referred to as the "battery eliminator circuit" (BEC). The choice of esc has to do purely with the demands on the current of the engine we are going to drive.



Fig. 20. ESC HobbyKing 30A

### G. Propellers

The propellers convert the rotary motion from a motor or other power source into a rotating sliding current or otherwise called a thrust. Each propeller is characterized by the basis of two geometric parameters, the diameter and the pitch. For making a choice we should take into account those parameters that determine the maximum thrust it can be produced. The diameter corresponds to the diameter of the circle in which the propeller rotates while the step is an indicator that shows how much the propeller will move forward in one turn. There are different types of propellers depending on their diameter and pitch, depending on the type of engine and the total weight of the application.



Fig. 21. Carbon fiber Propellers

## V. PROGRAMMING SCENARIO FOR THE QUADCOPTER

Our quadcopter, as we mentioned earlier, consists of four motors that are symmetrically attached to the ends of the main frame. A fixed pitch propeller is mounted on each engine. They use two pairs of identical propellers, two right-handed

propellers (CW) and two left-handed propellers (CCW). A typical layout of a quadcopter can be seen on the image below:

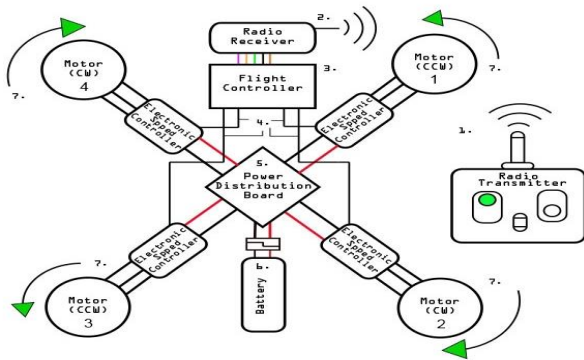

Fig. 22. Layout of a quadcopter.

As we can see, the main parts of a typical layout are the following:

- DC Brushless Motor
- ESC
- Flight Controller
- IMU
- Battery
- Propeller
- Transmitter - Receiver

The four available motors do not rotate in the same direction, two of them turn clockwise (CW) and the other two counterclockwise (CCW), thus the torque produced by the motors in the quadcopter body is zero. The torque depends on the angular velocity of the propellers, which means that the torques are reset only when all the propellers rotate at the same angular velocity, thus changing the angular velocities of the motors we can change its position. Any movement of the quadcopter is done through the wireless remote control which sends electrical signals to the central flight controller. The flight controller together with the information it receives from the sensors that make up the IMU performs calculations using flight parameters and mathematical algorithms. It then sends the computable data to each motor's electronic speed controllers, which then direct to increase or decrease their speed respectively.

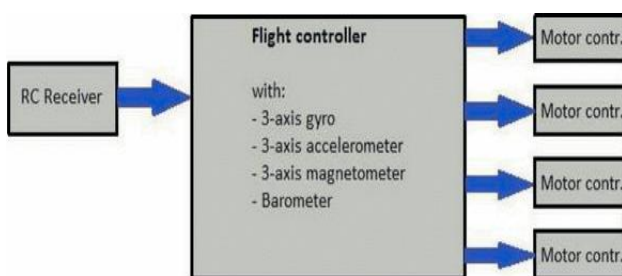

Fig. 23. Flight controller chart

The three rotational directions in which a quadcopter can move are called ROLL, PITCH and YAW.

Yaw: Rotates clockwise or counterclockwise from the Z axis.

Pitch: Directs either forward or backward along the X axis.

Roll: Direct either to the right or to the left along the Y axis.

By creating opposite variations in the angular velocities of the 2-3 and 1-4 propellers, the PITCH angle changes, resulting in forward or backward movement (Figure 1.10 (b)). Similarly, the angular velocity changes between the 1-2 and 3-4 propellers cause changes in the ROLL angle giving us the possibility of moving left or right (Figure 1.10 (c)). Also, if we change the angular velocity of propellers 1-3 and 2-4, the quadcopter rotates counterclockwise or clockwise on the YAW axis (Figure 1.10 (d)). Finally, the increase in angular velocity of the four propellers elevates the quadcopter while decreasing it down (Figure 1.10 (a)).

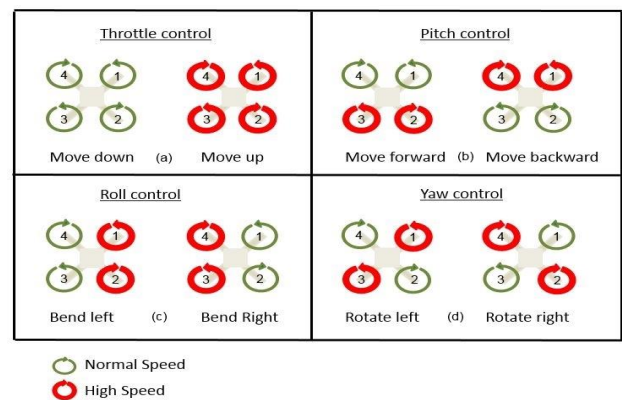

Fig. 24. Controlling the quadcopter

## VI. CONCLUSIONS AND FUTURE EXTENSIONS

The main purpose of this work was to develop both the hardware and the software of a quadcopter system. The difficulty of the project was given, as we had to develop our own software and build every piece of our construction from scratch. The know-how has been gained through the combination of theory and operations, enabling us to deepen our knowledge on a variety of subjects, in order to meet every need of our study and to familiarize ourselves with the design and construction of an integrated quadcopter system. Although its control and orientation calculations are based on the use of a single microcontroller, it is considered sufficient for a smooth flight and control. Its stabilization through the sequential controller implemented using an analogue P controller and a PID was considered optimal with respect to the use of a PID controller, either angular or angular velocity controller. Additionally, its complexity is small which results in limited additional delay in the run time of each loop. Other



control suggestions were considered to be of increased complexity without any improvement in the response of the system. The use of the supplemental filter even in high noise conditions has had very good results and given its small complexity it is considered a very good solution for low-power systems. Instead of a supplemental filter the Kalman filter can also be used, but this is not recommended due to increased complexity, although the results are similar to those of the supplement.

The quadcopter that we built, though fully functional, could be further developed in the future by adding some important functions, some of which would be:

- Create an autonomous navigation system.
- Position sensor distances around the frame to avoid obstacles.
- Telemetry to monitor all in-flight information.
- Placement of various sensors such as smoke, heat, CO<sub>2</sub>, etc. enabling it to be used in a variety of applications.

## VII. ACKNOWLEDGMENTS

All authors would like to thank the University of West Attica for the financial support provided to them for this research project.

## VIII. REFERENCES

- [1] <http://krossblade.com/history-of-quadcopters-and-multirotors/>
- [2] What is PID –Tutorial Overview. Date Accessed: 19 August 2011 Accessed: January 2012. <http://www.expertune.com/tutor.htm>
- [3] <https://www.dronezon.com/learn-about-drones-quadcopters/how-a-quadcopter-works-with-propellers-and-motors-direction-design-explained/>
- [4] Gogoi, Manoj Bouabdallah, S. & Siegwart, R. “Proportional Integral Derivative (PID) Controller Design For Robust Stability of Arbitrary Order Plants with Time Delay and Uncertainty” , 2007.
- [5] <https://www.byteparadigm.com/applications/introduction-to-i2c-and-spi-protocols/>
- [6] [https://en.wikipedia.org/wiki/Serial\\_Peripheral\\_Interface](https://en.wikipedia.org/wiki/Serial_Peripheral_Interface)
- [7] <https://formlabs.com/blog/3d-printing-technology-comparison-sla-dlp/>
- [8] <https://www.autodesk.com/products/eagle/overview>
- [9] <http://slic3r.org/>
- [10] <https://sites.google.com/site/myimuestimationexperience/filters/complementary-filter>
- [11] <http://electronicsmaker.com/sensors-and-connectivity-in-drones>
- [12] <https://www.dronezon.com/learn-about-drones-quadcopters/three-and-six-axis-gyro-stabilized-drones/>
- [13] <https://pdfs.semanticscholar.org/5328/684eeca10fe475a42873939d19766f7ac23a.pdf>
- [14] [https://aerospace.honeywell.com/en/~media/aerospace/files/technical-articles/applicationsofmagneto-resistivesensorsinnavigation-systems\\_ta.pdf](https://aerospace.honeywell.com/en/~media/aerospace/files/technical-articles/applicationsofmagneto-resistivesensorsinnavigation-systems_ta.pdf)
- [15] [https://www.nxp.com/filesstatic/32bit/doc/ref\\_manual/K66P144M180SF5RMV2.pdf](https://www.nxp.com/filesstatic/32bit/doc/ref_manual/K66P144M180SF5RMV2.pdf)
- [16] <https://gr.mouser.com/datasheet/2/389/13gd20h-954865.pdf>
- [17] <https://gr.mouser.com/datasheet/2/389/lsm303d-955044.pdf>
- [18] <https://gr.mouser.com/datasheet/2/389/lps22hd-1112295.pdf>

# IJEAST

INTERNATIONAL JOURNAL  
OF ENGINEERING APPLIED SCIENCE  
AND TECHNOLOGY

## ABOUT IJEAST

International Journal of Engineering Applied Science and Technology (IJEAST) is a peer-reviewed, open access journal that publishes high-quality research papers in the field of Engineering, Applied Science and Technology.

IJEAST aims to provide a platform for researchers, academicians, and professionals to share their innovative ideas, research findings, and practical experiences with the global scientific community.

## FOCUS AREAS

- Engineering
- Applied Science
- Technology
- Innovation & Development
- Interdisciplinary Studies



### PEER REVIEWED

All submissions are rigorously peer reviewed to ensure quality.



### OPEN ACCESS

Free and unrestricted access to research for all.



### GLOBAL REACH

Connecting researchers and professionals worldwide.



### TIMELY PUBLICATION

We ensure a swift and efficient publication process.



For more information, visit our website

[www.ijeast.com](http://www.ijeast.com)



INTERNATIONAL JOURNAL  
OF ENGINEERING APPLIED SCIENCE  
AND TECHNOLOGY

✉ [editor@ijeast.com](mailto:editor@ijeast.com)

🌐 [www.ijeast.com](http://www.ijeast.com)

📍 India



2455-2143