



IJEAST

INTERNATIONAL JOURNAL
OF ENGINEERING APPLIED SCIENCE
AND TECHNOLOGY



VOLUME : 7 ISSUE : 11 Print / Issue Publication Date: 14-May-2023



ISSN : 2455-2143



DOI : 10.33564/IJEAST.2023.v07i11.009

Indexed In



WWW.IJEAST.COM

editor@ijeast.com



PNEUMATIC BENCH VICE

Mohamed Shafi S

Department of Mechanical Engineering
Mohamed Sathak AJ College of Engineering

Purushothaman O H

Department of Mechanical Engineering
Mohamed Sathak AJ College of Engineering

Abstract— The goal of this project is to create a model of bench vice which is pneumatically operated. Using air pressure to create mechanical motion in the spindle of the vice provides a safe & efficient way to reduce human effort. The mechanical motion in the spindle is created with the help of a double actuating cylinder which is operated by a 5/2 pilot valve & two 3/2 push buttons with the help of the air hoses. A vice is a mechanical screw apparatus used for holding or clamping a work piece to allow work to be performed on it with tools such as saws, planes, drills, mills, screwdrivers, sandpaper, etc. Vices usually have one fixed jaw and another parallel jaw which is moved towards or away from the fixed jaw by the screw. Vice is used to drill a wood, metal, etc. by holding your work piece tightly, it gives you all stability you need so you can make precise cuts. Even it is used for sawing a job with constant force applied by hand, or automatically, in order to cut desired shapes. A pneumatic system is controlled through manual or automatic process. In this Automatic pneumatic vice project for metal working is provided with widely and quick movable clamping jaw and fixed jaw where the vertical clamping surface of the fixed jaw and the horizontal surface of the fastening plane for the working piece confirm an accurate and unchangeable. Using automatically operated pneumatic vice will help you to get the work down easily and save energy.

Keywords— screwdrivers, drills, mills, planes.

I. INTRODUCTION

Pneumatics is that part of innovation, which manages the review and utilization of purpose of compressed air to influence mechanical movement. "Pneumos" signifies "Air" and "Spasms" signifies "Innovation Pneumatics is utilizing air to push/pull things or suck them up. The cylinders and tubing are light and strong, lighter than comparable engines; in any case, the blower is itself an engine and is weighty. When the important choice to add the blower is made, adding additional cylinders is a lot more straightforward and lighter than adding additional engines (and outfitting). The air blower keeps air capacity tanks filled and the capacity

tanks give the hold air to fill the actuators or cylinders rapidly. Capacity tanks are no less than two times the tension of the actuators so one tank of capacity air will rapidly fill an actuator a similar size, yet after that the air blower can't renew the pre-owned air rapidly. It adds generally a portion of a cubic foot of air each moment relying upon the tension currently in the framework that it's endeavoring to push more air into. Less air is moved close to full tension (.24cfm) and more at nothing (.79cfm) pressure, so in a whole brief match anticipate that the air blower should add ~.8 cubic feet of air. Anticipate doing a test while watching the fundamental high-pressure check to perceive how low it gets during what you hope to be ordinary activity. A tight clamp or bad habit (see American and English spelling contrasts) is a mechanical screw device utilized for holding or quieting a work piece to permit work to be performed on it with instruments like saws, planes, drills, factories, screwdrivers, sandpaper, and so on. Tight clamps as a rule have one fixed jaw and another, equal, jaw is moved to work holding gadget. There are two principal types: a carpentry tight clamp and specialist's tight clamp. The woodwork tight clamp is working processer the hand, designing bad habit is utilized worked the little places. To comprehend how packed air can get things done, we should consider a ball. In the event that we explode the ball so it is full, it will contain a ton of compacted air. Assuming we skip the ball, it will bob exceptionally high. Nonetheless, in the event that the ball is exploded, the packed air will get away and the ball won't bob as high. Basically, the ball bobs since it is utilizing the energy put away in the packed air.

II. LITRATURE REVIEVE

Mechanical jacks were very common for jeeps and trucks. For example, the World War II jeeps (Willys MB and Ford GPW) were issued the "Jack, Automobile, Screw type, Capacity 1 1/2 ton", Ordnance part number 41-J-66. This jacks and similar jacks for trucks were activated by using the lug wrench as a handle for the jack's ratchet action to of the jack. The 41-J-66 jack was carried in the jeep's tool compartment. Screw type mechanical jack's continued in use for small capacity requirements due to low cost of production raise or lower it. A control tab is marked

up/down and its position determines the direction of movement and almost no maintenance. Thomas J. Prather (2009): In this, there was an introduction about vehicle lift system. A drive assembly was mechanically coupled to the piston. The drive assembly was operated in first direction to raise an upper end of the piston with respect to the housing. The drive assembly was operated in a second direction to lower the upper end of the piston with respect to the housing. The drive assembly was coupled to the power supply port which is removable to supply electrical power to the drive assembly. Lokhande Tarachand (2012): This paper referred to optimize the efficiency of square threaded mechanical screw jack by varying different helix angle. Manoj Patil (2014): In this general article, screw jack is developed to overcome the human effort. It is actually difficult job to operate for pregnant women and old person. Changing the tyre is not a pleasant experience. Especially women can't apply more force to operate. For that, electric operated car jack is introduced. With the industrial revolution of the late 18th and 19th centuries came the first use of screws in machine tools, via English inventors such as John Wilkinson and Henry Maudsley The most notable inventor in mechanical engineering from the early 1800s was undoubtedly the mechanical genius Joseph Whitworth, who recognized the need for precision had become as important in industry as the provision of power. In Alleghany County near Pittsburgh in 1883, an enterprising Mississippi river boat captain named Josiah Barrett had an idea for a ratchet jack that would pull barges together to form a „tow“. The idea was based on the familiar lever and fulcrum principle and he needed someone to manufacture it.

B. BENCH VICE

It's a gadget used to hold the work pieces for various machining tasks, for example, fitting, completing and so on and is fixed to the work table with the screws and nuts through openings gave on the bad habit base.

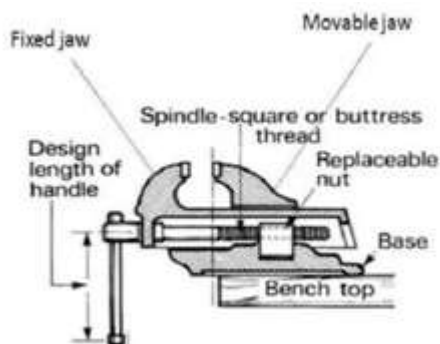

It consists of four main parts:

- **FIXED JAW:** It is usually cast integral with vice body or base.

- **MOVABLE JAW:** It slides on the ways of the casting & is operated with a screw or spindle.
- **SCREW:** It gives movable jaw the forward or backward movement.
- **CASTING:** It constitutes the base of the vice & has ways for the movable bar.

C. TYPES

MACHINIST VICE: Also called as engineering vice, it's a heavy duty vice made of ductile iron. There are two main differences b/w machinist vices & other vices: 1. Thick metal construction

2. **Mount:** A machinist vice is mounted with bolts to the top of a worktable. Its heavy metal construction gives it the ability to tolerate repeated, heavy strain. Depending on the base, a machinist vice might have multiple functions.

MECHANIC VICE:

The mechanic vice is designed to function more than a mere vice having a swivel base. They usually have an integrated anvil area & are made of low grade iron.

POST VICE:

It's a blacksmith tool & features a post going to ground so it may be hammered upon. These vices are made of forged wrought iron allowing them to have ductility. It is therefore possible to spring the jaws without breaking them.

WOOD WORKER VICE:

It's a under mount vice with retractable dog for clamping the work upon the workbench.



FIG1.2 MACHINIST VICE FIG1.21MECHANICVICE



FIG 1.22POST VICE FIG 1.23WOODWORKVICE

D: MATERIALS

The bench vices are usually made of cast iron or ductile iron. The phrase cast iron usually implies grey or white cast irons which are brittle due to significant graphite component existing in the iron in flakes.

Ductile iron graphite is in a nodular shape which inhibits cracking. It's an important distinction in vices because high quality vices are made from nodular or spheroid iron & cheaply made economy vices are made of grey cast iron.

1) Components

- Pneumatic Actuator
- Pneumatic Parts & Fittings
- Vice Heads
- Connecting Rods
- Base Frame
- Mounts & Joints
- Screws & Fittings

III. PNEUMATICS

Pneumatics is the discipline that arrangements with the mechanical properties of gases like strain and thickness and applies the rule to involve packed gas as a wellspring of ability to tackle designing issue. The most broadly utilized packed gas is air and in this way its utilization has become inseparable from the term pneumatics.

Today the most important property of the medium air is the simple conversion of pressure into force & translational displacement using a piston in a circular bore.

a) ADVANTAGES OF AIR

- Does not generate sparks.
- Poses no health hazard.
- Can be easily stored.
- Atmospheric air is free & this had led to statement that compressed air is a cheap form of energy.

Due to low viscosity, air cannot be used to lubricate the machinery it actuates. However, advances in electronics helped to develop control systems for electric drives that made them superior to formerly used fluid power actuators. This technology can also enhance the performance of the pneumatic drives.

Examples are pressure controlled chambers in lorry braking circuits or position controlled actuators for process valves. Typical ranges of pneumatic systems are shown in figure below:

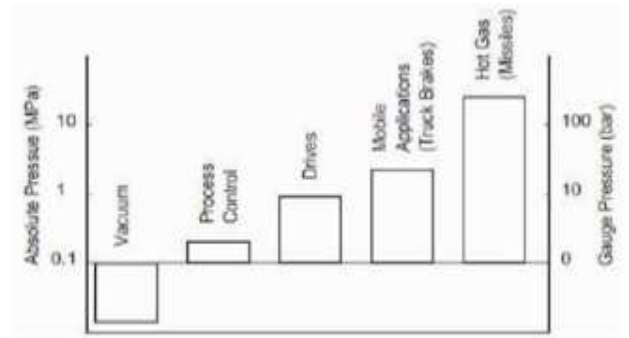

AREA OF APPLICATION OF PNEUMATICS

- Damp Hopper
- Stamping
- Mining(Door opening & closing)
- Material flow
- Automobile (Braking System, engine etc.)
- Tools (Jackhammer, drills etc.)
- Punching
- Motion Restriction in CNC machines
- Dental Care
- Pneumatic gun for bolt tightening



2.ELEMENTS OF A BASIC COMPRESSED AIR PNEUMATIC SYSTEM

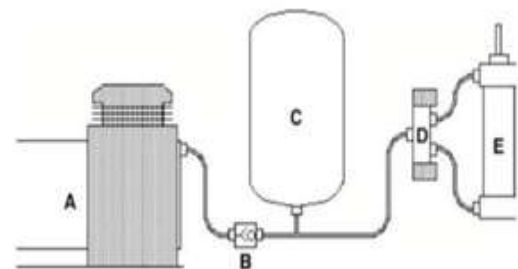

AIR COMPRESSOR

Driven with the assistance of an electric engine, it packs the air raising gaseous tension to above surrounding strain for use in pneumatic framework. Normally utilized air blowers are the ones where progressive volumes of air are disconnected and then, at that point, compacted. These are:

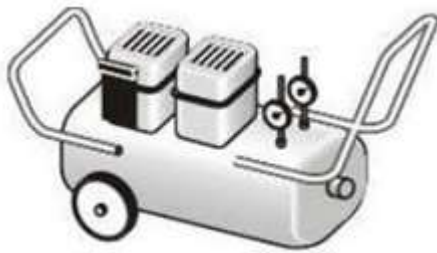
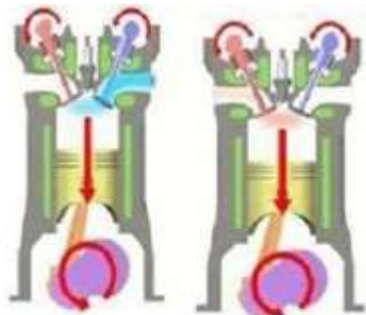

FIG 2.3 COMPRESSOR

SINGLE ACTING, SINGLE STAGE, VERTICAL RECIPROCATING COMPRESSOR

As shown in the figure, on the air intake stroke the descending piston causes air to be sucked into the chamber through the spring loaded inlet valve & when the piston starts to rise again, the trapped air forces the inlet valve to close & so becomes compressed. When the air pressure has risen sufficiently, the spring loaded outlet valve opens & the trapped air flows into the compressed.



IV. EXPERIMENTAL SETUP

This chapter presents the discussion on the experimental setup, experimental targets & strategies taken while doing the project. It provides a brief overview & complete details of the bench vice with pneumatic setup.

4.2. THE MODEL

A model of bench vice coupled with double acting cylinder which is operated by 5/2 pilot valve & 3/2 push button (spring return) is used for the test purpose.

4.3. EXPERIMENTAL TARGET

The experiment was designed to hold the workpiece with the help of the pneumatic force provided by the double acting cylinder rod.

4.4. EXPERIMENTAL STRATEGY

The experimental strategy was to design a bench vice with mild steel as a material & then couple it with the rod of the double acting cylinder so as to obtain the desired pneumatic force which is used to hold the work piece.

SCHEMATIC DIAGRAM

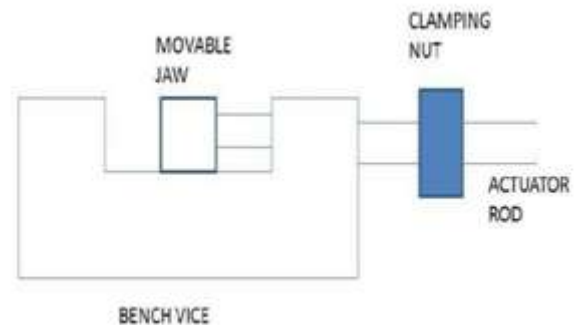

PROCEDURE:

Design a bench vice with the mild steel as its material. (Designing is done in CATIA V5 which can be seen on APPENDIX I) A double acting cylinder is coupled with the 5/2 pilot valve & 3/2 push button with the help of air hoses & its working has been checked. (pneumatic drawing is done with the help of FESTO FLUID DRAW 5 DEMO which can be seen on APPENDIX II). The bench vice is bolted to the wooden work table. The double acting cylinder is now bolted to the wooden work table from one side & on another side it is placed in a frame which is bolted to the wooden work table at a specified distance. The frame is shown in the figure below:

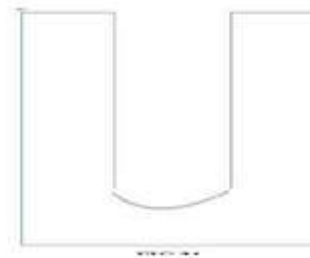

The advantage of using frame is that the cylinder rod can be aligned accurately with the bench vice spindle. The cylinder rod is clamped to the bench vice spindle. Working of bench vice is then checked by operating it with the help of push buttons.

B. Experimental Results & Discussions

The project strategy was to operate the bench vice with the help of the mechanical motion obtained by the cylinder rod from the pneumatic force supplied by the system. The present chapter includes the result obtained by implementing this strategy.

PNEUMATIC BENCH VICE ANALYSIS

It has been found that this bench vice can be used to hold the work pieces of different sizes & weights with different pressures varied with the help of the pressure regulator. Also, the stroke of the movable jaw in backward direction is

not complete due to short stroke length of the cylinder rod of the double actuating cylinder (The movable jaw displacement from the fixed jaw can be changed or nullified by changing the stroke length of the cylinder rod of the actuator).

CALCULATION

1 BAR = 100Kpa
 = 100KNm

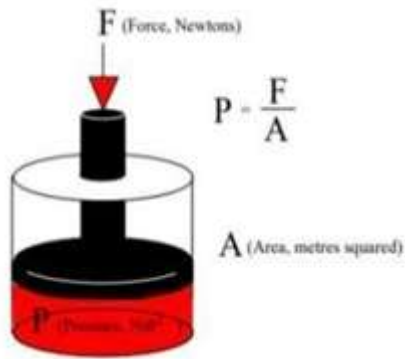

$$P = \frac{F}{A}$$

Equation $P = F/A$

$$P = 10 \text{ bar} = 1.01 \text{ N/mm}^2$$

Diameter of Piston = $d = 50 \text{ mm}$

$$A = (3.14/4) * d * d$$

$$= (3.14 / 4) * 50 * 50 = 1963 \text{ mm}^2$$

MATERIAL OF THE BENCH
 VICE: MILD STEEL CYLINDER:
 DOUBLE ACTUATING VALVE:
 5/2 PILOT VALVE
 3/2 SPRING RETURN
 PUSH BUTTON VALVE

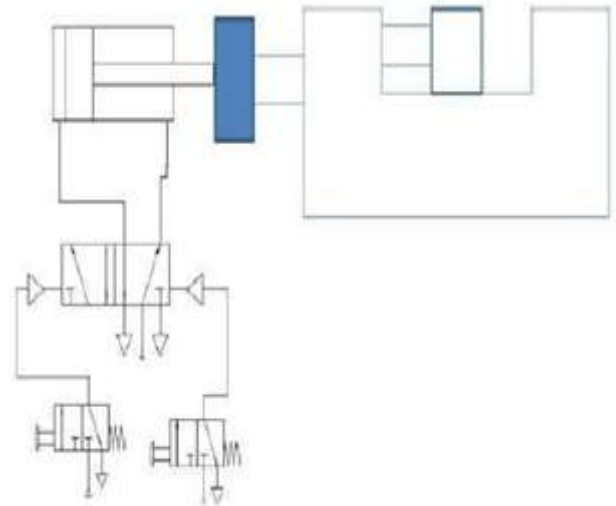

V. REFERENCE

- [1]. Robotics Eagle, Pneumatic System 2020<http://team358.org/files/pneumatic/Pneumatics StepByStep.pdf>
- [2]. http://www.team358.org/files/pneumatic2011 FIRST_Robotics_Compition_Pneumatics_Manual_Rev_B.pdf
- [3]. Vice with Automatic, guidelines Tips_Good%20Practices_RevC.pdf Diameter of Piston = $d = 50 \text{ mm}$
- [4]. http://team358.org/files/pneumatic/MEAD_pneumatic_handbook.pdf
- [5]. <http://team358.org/files/pneumatic/SY3000valveAs-sembly.Pdf>

IJEAST

INTERNATIONAL JOURNAL
OF ENGINEERING APPLIED SCIENCE
AND TECHNOLOGY

ABOUT IJEAST

International Journal of Engineering Applied Science and Technology (IJEAST) is a peer-reviewed, open access journal that publishes high-quality research papers in the field of Engineering, Applied Science and Technology.

IJEAST aims to provide a platform for researchers, academicians, and professionals to share their innovative ideas, research findings, and practical experiences with the global scientific community.

FOCUS AREAS

- Engineering
- Applied Science
- Technology
- Innovation & Development
- Interdisciplinary Studies



PEER REVIEWED

All submissions are rigorously peer reviewed to ensure quality.



OPEN ACCESS

Free and unrestricted access to research for all.



GLOBAL REACH

Connecting researchers and professionals worldwide.



TIMELY PUBLICATION

We ensure a swift and efficient publication process.



For more information, visit our website
www.ijeast.com



INTERNATIONAL JOURNAL
OF ENGINEERING APPLIED SCIENCE
AND TECHNOLOGY

✉ editor@ijeast.com

🌐 www.ijeast.com

📍 India



2455-2143