



IJEAST

INTERNATIONAL JOURNAL
OF ENGINEERING APPLIED SCIENCE
AND TECHNOLOGY



VOLUME : 4 ISSUE : 12 Print / Issue Publication Date: 10-Jun-2020



ISSN : 2455-2143



DOI : 10.33564/IJEAST.2020.v04i12.093

Indexed In



WWW.IJEAST.COM

editor@ijeast.com



DESIGN AND IMPLEMENTATION OF HYBRID POWER GENERATION USING SOLAR AND PELTIER PLATE

Mrs. K. Fathima
Assistant Professor,
Department of Electrical
and Electronics
Engineering, Vel Tech,
Chennai, India

K. N. Asniya
Students, Department of
Electrical and Electronics
Engineering, Vel Tech,
Chennai, India

V. Krithika
UG Students, Department
of Electrical and
Electronics Engineering,
Vel Tech, Chennai, India

M. Mahalakshmi
UG Students, Department
of Electrical and
Electronics Engineering,
Vel Tech, Chennai, India

Abstract—This manuscript establishes the use of thermal dissipation energy management to increase effectiveness of solar cells. Energy radiated from sun is restored as an alternative energy source along with the energy generated by the Peltier plate. The nature of Peltier plate enables it to capture the heat dissipation from the surroundings and convert into an Electrical energy. The material used in Peltier plate is Bismuth Telluride Semiconductor. This hybrid technology increases the efficiency of the solar power system which helps us to use the green energy both in the presence and absence of sunlight.

Keywords—solar panel, peltier plate.

I. INTRODUCTION

In today's world, it is necessity to maximize power generation capacitance due to constant increase in consumption of electrical energy. To obtain, renewable energy is better choice. In current scenario the resource of fossil fuels is the source of energy which we rely upon, but it would exhausted soon because oil denotes restricted resource. Therefore, to overwhelm employ as renewable energy sources will also implement a clean surrounding to upcoming generation.

Among the available renewable energy sources, the system of solar power generation in upper list. However solar energy may only be derived in the presence of sunlight, we can hybridize it with Peltier plate. Solar and Peltier energy is restored in battery. This type of mechanism will increase the life of cell, improve performance, as well as implement equipped advantages at various conditions of surrounding (Changchien et al., 2010).

In significant factors select the type of renewable generator as time, location, as well as user requires. Information on climate energy sources as well as temperature availability is associated with locations. Energy plays an integral role in the socioeconomic evolvement of the society. Power plays a big

role anywhere there are livelihoods (Chen et al., 2011; Daud et al., 2012).

The consumption of electricity by the people is growing in an exponential proportion because of the industrial expansion and electrical gadgets usage. We utilize almost 0.8% conventional fossil fuels energy such as oil (0.36%), natural gas (0.21%) and coal (0.23%). In a work like this, solar energy converts radiant light into electrical energy, as well as Peltier plate converts heat energy into electrical energy. Power can be generated using solar panels due to the seasons by plenty of sunlight. When, thermoelectric generator systems implements power as well as heat is needed due to seasons by insufficient sunlight (Wu et al., 2013; Kugele et al., 1996).

II. METHOD OF PELTIER MODULE

In Peltier module denotes thermoelectric device has semiconductors of p-type as well as n-type. The module uses the principle of seebeck effect in converting heat energy into electricity. When two different semiconductor materials with different heat proportion are present across, it induces a voltage which in turn results in thermo electric power generation. This phenomenon is said to be as effect of seebeck. While electrical energy is generated in a circuit with two semiconductors, a temperature variance is generated at two junctions. This is known as peltier plate (Meng et al., 2015; Wai et al., 2008).

The Peltier device consists of two ceramic plates associated to electrical conductor, two semiconductor poles (type P and N). Seebeck generator contains numerous poles (P and N type) and every pair of legs form a thermoelectric couple. In a single conducting material which already has a temperature difference, an electric is allowed to flow by which heat is either held or dissipated over the solid. This phenomenon is known as the Joule- Kelvin expansion. Thus energy produced by this thermoelectric device is either utilized for heating or cooling (Zhang et al., 2008a; Zhang et al., 2008b).

When one side of the peltier plate is heated it pushes the electrons away from the high temperature end towards the low temperature end. As a result, electricity is produced.

A viable thermoelectric conductor has great thermoelectric power, large electrical conductivity, as well as small thermal conductivity. When one surface of the thermo electric generator is heated, the electron charge carriers present in the n-model semiconducting material and the perforation present in the p-model semiconducting material will move away from the thermal source. An electrical is produced due to this movement of charge carriers. The flow of current is in the direction opposite to that of association of electrons as well as at similar direction of movement of holes (Fritts, 1963; Yoneda et al., 2001; Chen, 1998).

III. PRINCIPLE OF SOLAR MODULE

Solar energy is considered one of the main renewable energy sources, as it is readily obtainable, clean as well as cheap. Nowadays, the production of solar energy is provided more significance due to its rapid technological evlvement as well as possible use towards global energy demands. The photovoltaic cell works on the effect of photovoltaic. The monocrystalline silicon solar cell (mc-Si) denotes part of silicon as solar cell family. The overall performance of a solar cell based on surrounding and irradiation conditions and the cell's tracking angle and temperature.

As the solar panel contains photocells, when it is displayed in the daylight, these photocells convert light energy straightly with 3Telectricity3T through 3T photovoltaic effect3T. Solar array power DC as well as peltier plate of DC with rechargeable battery in hybrid system.

Thus, this system can be used at any time of the day. Generated DC is converted into AC by connecting the battery to an inverter board. AC appliances via step up transformer are switched on through this AC voltage feed.

IV. EXPLANATION

It has peltier foil, solar panel, charge components, rechargeable units, DC motor, inverter, step up transformer as well as AC load and AC motor.

Output of solar and peltier plate associated with battery by charging circuit. Charging circuit converts variable voltage to constant regulated voltage, thus functioning as an electric regulator.

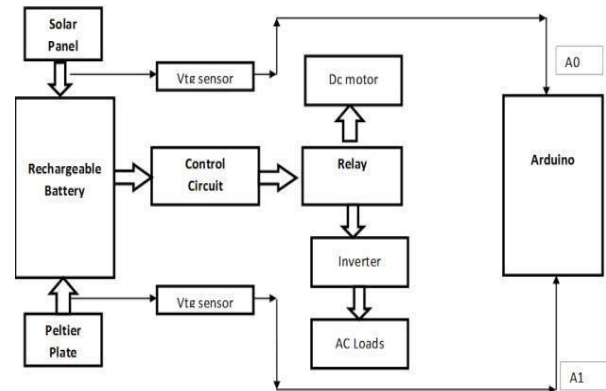

Fig.1. Block Diagram

It includes a solar panel, peltier plate, charging circuit; rechargeable controller prevents hybrid system from overcharging the battery. This supported by power management module which will keep account of the usage of the power stored in an efficient manner.

When the battery is fully charged, controller stops or reduces as flow of current to battery as system of power generations.

Since, battery output denotes DC; it may be straightly connected with DC load. For AC load, an inverter is employed to convert DC to AC, as well as battery is associated with inverter board by convert the DC to AC voltage generated. Thus, this system can be used at any time of the day.

Generated DC is converted into AC by connecting the battery to an inverter board. AC appliances via step up transformer are switched on through this AC voltage feed.

V. POWER UNIT

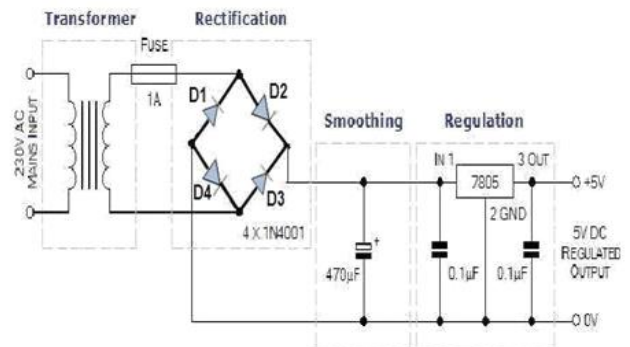

Fig.2. Power Supply

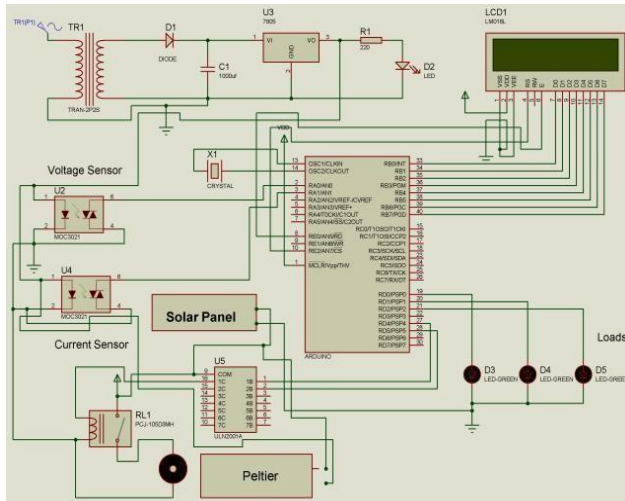

Fig.3. PIN Diagram

Generally, the step down transformers are used for converting high voltage into low voltage. It converts 230 volts into 12 volts according to the requirement of the circuit. It converts AC into DC. The fuse present in the circuit breaks the connection whenever a power fluctuation takes place, in order to prevent the circuit from damage. The bridge rectifier is used to provide the same output polarity for either input polarity. The filter is used for smoothing the ripples present in the single. An integrated circuit converts unregulated AC by stable DC to power supply regulated.

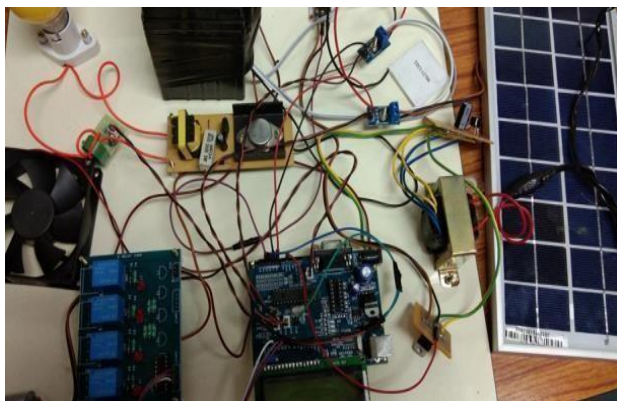

Fig.4. Hardware Kit

VI. DISCUSSION OF RESULT

Arduino the most efficient software used to analyse the battery withstand level and the switch over of voltage. The battery is recharged from two sources. In the presence of sunlight the solar panel can charge the battery. In the absence of sunlight the Peltier plate can charge the battery. The arduino is design and programmed in such a way that if battery level is low

which varies from 0 to 4 volt then load I (FAN) will be switched on and starts operating. At that time remaining two loads will be switched off. Similarly arduino is already coded in such a way that if battery level is medium which varies from 4 to 7 volt then load

II (MOTOR) will be switched on and starts operating . At that time load III will be switched off. If battery level is high which varies from 7 to 12 volt then all the loads will be operated.

It helps to determine the load and switch powers; cost efficient, performance, power consumption reduced by energy drain and used to check out the effectiveness system of power generation. The peltier module is a reliable source of power as it can work for long duration of hours continuously compared to other sources.

Due to the thermal lag, there is a very short heating up and cooling time in the TEC modules. The max temperature variance may be reached as one minute, beneath the condition as better heat indulgence on the hot side as well as no load at cold side. In this tec is a device that converts current- to-energy. .It achieves a high precision temperature control by controlling the current source. By this, an automatic control system can be built with remote control and computer control this helps to perform load scheduling. During power shortage we can make use of this device for power management and generation.

VII. RESULT AND FUTURE SCOPE

Further it can be implemented using a internet of things through which we can monitor the data by an emerging technology Big data

Big data is an essential element for power management and control towards the efficiency in power distribution network.

VIII. APPLICATION

In hospitals in case of emergency if there is any shortage of power and there is a need of immediate power supply Peltier Plates absorbs heat energy from the nearby devices which is converted into electrical energy and transmitted to the required battery.

Many institutions, such as furnace regions, industrial areas, and other locations are ideal purpose of establishing such energy centres where the heat dissipated are easily available for the recycling and conversion to the same system.

IX. CONCLUSION

This paper proposes that the energy that is exhausted as conversion of solar energy into electrical energy in the solar panel may be preserved as well as greater competence reached. These sources can help to execute DC motor, AC motor, and many other loads. Based on the power production, loads are swithed on and off process take place. By this,



finally we are generating power using hybrid sources and load scheduling.

Technology. Proceedings (Cat. No. 98EX105) (p. 860)..

X. REFERENCE

- [1] Changchien S.K., Liang T. J., and Yang L. S. (2010). Novel high step up dc-dc converter for fuel cell energy conversion system. *IEEE Trans Ind. Electron*, vol. 57, (pp. 2007–2017).
- [2] Chen S., Liang T. and Chen J. (2011). A cascaded high step-up dc-dc converter with single switch for Microsource applications, *IEEE Trans. Power Electron.*, vol. 26, (pp. 1146–1153).
- [3] Daud D., Nursyarizal Bin Mohd Nor., and Ibrahim T. (2012). Novel hybrid photovoltaic and thermoelectric panel, *IEEE International Power Engineering and Optimization Conference*, 2012.
- [4] Wu H., Sun k., Chen z., Chen., and Xing. (2013). Hybrid centralized-distributed power conditioning system for thermoelectric generator with high energy efficiency 2013, *IEEE Energy Conversion Congress and Exposition*.
- [5] Kugele R., Roth W., Schulz W., and Steinhuser A. (1996). Thermoelectric generators in photovoltaic hybrid systems, *Fifteenth International Conference on Thermoelectrics. Proceedings ICT '96*.
- [6] Meng N., Wang P., Wu H., Wang W., and Xu W. (2015), Optimal sizing of distributed generations in a connected DC micro-grid with hybrid energy storage system. *IEEE Energy Conversion Congress and Exposition (ECCE)*.
- [7] Wai R.J, Lin C.Y., Zuan D.Y, and Chang Y.R. (2008). High-Efficiency Power Conversion System for Kilowatt-Level Stand-Alone Generation Unit With Low Input Voltage, *IEEE Transactions on Industrial Electronics*, 55(10), pp. 3702-3714.
- [8] Zhang X., Chau K., Chan C., and Gao. S. (2008a). An automotive thermoelectric-photovoltaic hybrid energy system, *2010 IEEE Vehicle Power and Propulsion Conference*, 2010.
- [9] Zhang X., Chau K., Yu C., and Chan C. (2008b). An optimal solar-thermoelectric hybrid energy system for hybrid electric vehicles. *IEEE Vehicle Power and Propulsion Conference*, 2008.
- [10] Fritts, R. W. (1963). The development of thermoelectric power generators. *Proceedings of the IEEE*, 51(5), 713-721.
- [11] Yoneda, S., Ohta, E., Kaibe, H. T., Ohsugi, I. J., Shinohara, Y., and Nishida, I. A. (2001). Possibility of improvement of thermoelectric properties of $Pb_{1-x}Sn_xTe$ by the functionally graded material. *Journal of Advanced Science*, 12(4), 379-384.
- [12] Chen, G. (1998, October). Heat conduction in low-dimensional structures. In *1998 5th International Conference on Solid-State and Integrated Circuit*

IJEAST

INTERNATIONAL JOURNAL
OF ENGINEERING APPLIED SCIENCE
AND TECHNOLOGY

ABOUT IJEAST

International Journal of Engineering Applied Science and Technology (IJEAST) is a peer-reviewed, open access journal that publishes high-quality research papers in the field of Engineering, Applied Science and Technology.

IJEAST aims to provide a platform for researchers, academicians, and professionals to share their innovative ideas, research findings, and practical experiences with the global scientific community.

FOCUS AREAS

- Engineering
- Applied Science
- Technology
- Innovation & Development
- Interdisciplinary Studies



PEER REVIEWED

All submissions are rigorously peer reviewed to ensure quality.



OPEN ACCESS

Free and unrestricted access to research for all.



GLOBAL REACH

Connecting researchers and professionals worldwide.



TIMELY PUBLICATION

We ensure a swift and efficient publication process.



For more information, visit our website

www.ijeast.com



INTERNATIONAL JOURNAL
OF ENGINEERING APPLIED SCIENCE
AND TECHNOLOGY

✉ editor@ijeast.com

🌐 www.ijeast.com

📍 India



2455-2143