



IJEAST

INTERNATIONAL JOURNAL
OF ENGINEERING APPLIED SCIENCE
AND TECHNOLOGY



VOLUME : 5 ISSUE : 3 Print / Issue Publication Date: 15-Sep-2020



ISSN : 2455-2143



DOI : 10.33564/IJEAST.2020.v05i03.087

Indexed In



WWW.IJEAST.COM

editor@ijeast.com



OPTIMIZATION AND MODELLING OF CONTROL ALGORITHM FOR BRUSHLESS DC MOTOR IN-SITU OF DC MICROGRID

Vishwateja B
M.Tech, Dept. of EEE
B.M.S. College of Engineering,
Bengaluru, India

Dr Pradeepa S
Professor, Dept. of EEE
B.M.S. College of Engineering,
Bengaluru, India

Abstract- This paper carry out the implementation of flyback converter fed brushless direct current motor using neuro fuzzy logic control with PV as source. The proposed controller is used for torque control of a brushless direct current motor. To determine the effectiveness of the flyback converter fed brushless direct current motor using Neuro fuzzy logic control, the Zeta converter fed brushless direct current motor is compared using Fuzzy logic control. Implementation of the method is comparatively simple because it requires less calculation compared against fuzzy logic and neural networks.

Keywords - Zeta converter, Flyback converter, Fuzzy logic, Neuro-fuzzy logic, BLDC motor

I. INTRODUCTION

The continuously rising carbon emission and declining of fossil fuels embolden the consumers to adopt the sustainable energy. Developing physical, bountiful and renewable solar energy technologies will have tremendous benefits in the longer term. It will increase energy security for countries by relying on renewable, inexhaustible and mostly imported independent resources, boost sustainability, reduce emissions, reduce climate change mitigation costs and keep fossil fuel prices lower. Solar PV generation is emerging as the best option for various applications of non-renewable energy sources. With reference to this, the attempt has been made to integrate photovoltaic module with the brushless DC motor via Flyback converter and Neuro-Fuzzy logic control for various domestic load with gratifying output and cost effective approach. This leads to a more convenient step towards renewable energy and can be supported and introduced and used extensively for household purposes. The conventionally used induction motor is powerful, low cost and low maintenance requirements. However, induction motor has various drawbacks, such as problem overheating and complex control requirements. Hence the proposed Brushless DC motor has higher efficiency and low

torque ripple and it has no maintenance thus it is cost efficient.

A. BLDC MOTOR

The direct current motors are highly efficient where their only major downside is also that they require a mechanical switch as well as brushes which are prone to wear and tear but also require maintenance. DC machines are risky to be used in dangerous circumstances, while the brush would spark during vital operating conditions such as dynamic loading and abrupt reversing of velocity. The brushless direct current motors were also permanent magnet motors with solid state switches which really control the characteristics of both the switches and brushes. The brushless direct current motors were renowned of its high performance and low maintenance. The six circuit switch acts as just a mechanical switch.

BLDC machines can be classified by rotor permanent magnet location, geometrically depending on how the magnets are placed on the rotor. The magnets may either be placed on the surface or interior. In the case of surface mounted PM rotors per permanent magnet is mounted on the rotor surface. It is simple to create, and specially skewed poles are easily magnetised on this type of surface installed to reduce the cogging torque. But there's a risk it could break apart during high speed operation. In the case of an interior PM rotor per permanent magnet is installed within the rotor and is a great replacement for high speed operation. In the case of stator winding, there are two main types of brushless direct current motor drives that can all be represented by the shapes of their respective back EMF waveforms, namely trapezoidal and sinusoidal.

A brushless direct current motor is essentially a normal DC motor spinning inside and out. It ensures a coil is installed on the stator and permanent magnets in the rotor. The stator and rotor will not touch one another and directly. The stator consists of several coils, in which the current has been produced by a magnetic field which spins a rotor. Normally three phases offer six multiple ways to let the current flow it through coils. Of every brushless direct current motor the

moving elements were its magnets. This leads as in absence of the change in brushes with in brushless direct current motor that assures high reliability as well as longer service period since brushes or commutators are not there.

B. MATHEMATICAL MODELING OF BLDC MOTOR

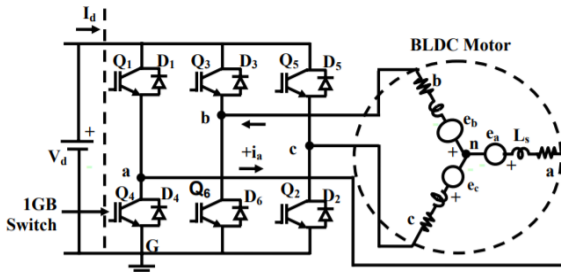

Fig 1- Dynamic model of BLDC motor

$$\begin{bmatrix} V_{an} \\ V_{bn} \\ V_{cn} \end{bmatrix} = \begin{bmatrix} R_s & 0 & 0 \\ 0 & R_s & 0 \\ 0 & 0 & R_s \end{bmatrix} \begin{bmatrix} i_a \\ i_b \\ i_c \end{bmatrix} + \begin{bmatrix} L & M & M \\ M & L & M \\ M & M & L \end{bmatrix} p \begin{bmatrix} i_a \\ i_b \\ i_c \end{bmatrix} + \begin{bmatrix} e_a \\ e_b \\ e_c \end{bmatrix}$$

Where, $e_a = K_a w_r$, $e_b = K_b w_r$, $e_c = K_c w_r$

$$i_a + i_b + i_c = 0, \text{ (or) } i_b + i_c = -i_a$$

$$V_{an} = R_s i_a + L \frac{di_a}{dt} + M \frac{d}{dt} (i_b + i_c) + e_a$$

$$V_{an} = R_s i_a + L_s \frac{di_a}{dt} - M \frac{di_a}{dt} + e_a$$

$$V_{bn} = R_s i_b + L_s \frac{di_b}{dt} - M \frac{di_b}{dt} + e_b$$

$$V_{cn} = R_s i_c + L_s \frac{di_c}{dt} + M \frac{di_c}{dt} + e_c$$

$$\begin{bmatrix} V_{an} \\ V_{bn} \\ V_{cn} \end{bmatrix} = \begin{bmatrix} R_s & 0 & 0 \\ 0 & R_s & 0 \\ 0 & 0 & R_s \end{bmatrix} \begin{bmatrix} i_a \\ i_b \\ i_c \end{bmatrix} + L_s \begin{bmatrix} \frac{di_a}{dt} \\ \frac{di_b}{dt} \\ \frac{di_c}{dt} \end{bmatrix} + \begin{bmatrix} e_a \\ e_b \\ e_c \end{bmatrix}$$

$$\begin{bmatrix} \frac{di_a}{dt} \\ \frac{di_b}{dt} \\ \frac{di_c}{dt} \end{bmatrix} = \left\{ \begin{bmatrix} V_{an} \\ V_{bn} \\ V_{cn} \end{bmatrix} - \begin{bmatrix} R_s & 0 & 0 \\ 0 & R_s & 0 \\ 0 & 0 & R_s \end{bmatrix} \begin{bmatrix} i_a \\ i_b \\ i_c \end{bmatrix} - \begin{bmatrix} e_a \\ e_b \\ e_c \end{bmatrix} \right\} * \frac{1}{L_s}$$

$$P_m = (e_a i_a + e_b i_b + e_c i_c)$$

$$T = \frac{P_m}{w_{rm}} = \frac{P P_m}{2 w_r} = \frac{(e_a i_a + e_b i_b + e_c i_c) P}{2 w_r}$$

$$T = \frac{P (K_a i_a + K_b i_b + K_c i_c) w_r}{2 w_r}$$

$$T = \frac{P}{2} (K_a i_a + K_b i_b + K_c i_c)$$

$$\frac{J}{P/2} * \frac{dw_r}{dt} + \frac{B}{P/2} * w_r + T_1 = T$$

$$\frac{dw_r}{dt} = \frac{P}{J} (T - T_1 - \frac{B}{P/2} * w_r)$$

C. ZETA CONVERTER

A Zeta converter is a DC-DC converter that involves two inductors as well as two condensers, and therefore can perform whether step-up or step-down mode.

Advantages:

- It is a converter of the buck-boost kind, that means you can raise the voltage and also step down.
- This gives greater performance and improved voltage than the standard buck-boost converter.

Disadvantages:

- The input current is discontinuous, undesirable for certain applications.
- Requirement for passive elements is more.

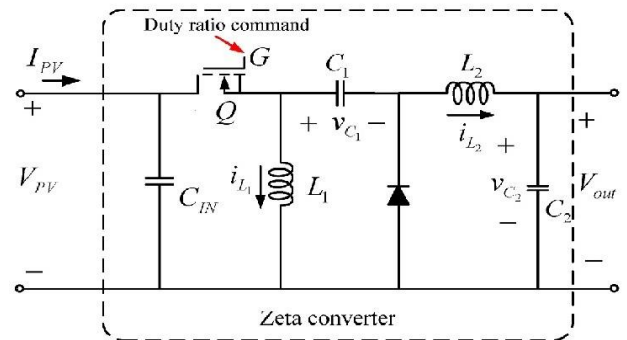

Fig 2- Zeta converter

D. FUZZY LOGIC CONTROL

A Fuzzy Logic Control System, a mathematical system which analyzes analog input data on the basis of logical variables which assume continuous value of 0 or 1, just like compared to classical as well as modern logic which operates rather on 1 or 0 binary values (true or false), accordingly.

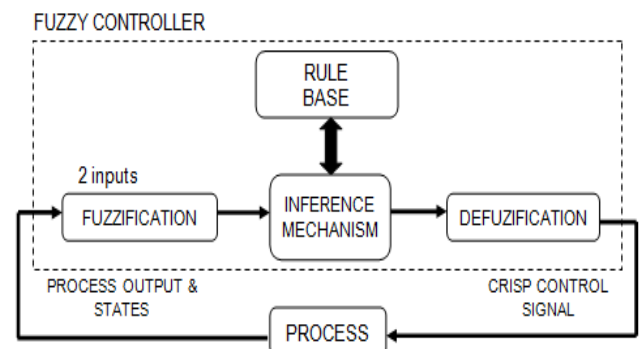

Fig 3- Fuzzy logic controller

Principle of fuzzy modelling

- I. Fuzzification- Process where certain membership functions have been used to convert the real scalar value to a fuzzy value.
- II. Fuzzy Inference- A framework that uses Fuzzy set theory to map input to output.
- III. Defuzzification- This is the last step to obtain quantifiable results in crisp logic using the specified fuzzy set and membership function.

II. SIMULATION DESIGN OF ZETA CONVERTER FED BRUSHLESS DIRECT CURRENT MOTOR USING FUZZY LOGIC CONTROLLER

The current simulation configuration is shows the zeta converter to capture the power from the sunlight to photovoltaic (PV) array that is then converted to an AC using inverter. The fuzzy controller is used to regulate the output speed Brushless Direct current motor.

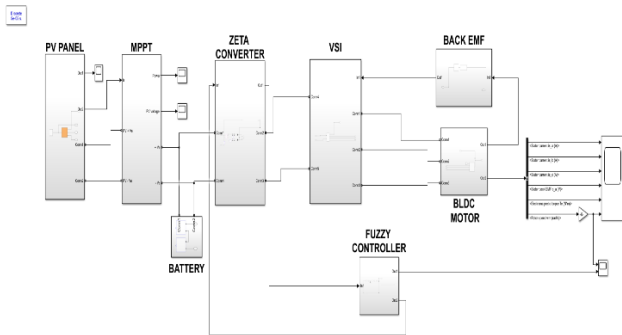

Fig 4- Simulation circuit of brushless direct current motor control using Fuzzy logic controller

A. SIMULATION WAVEFORMS OF ZETA CONVERTER FED BRUSHLESS DIRECT CURRENT MOTOR USING FUZZY LOGIC CONTROLLER

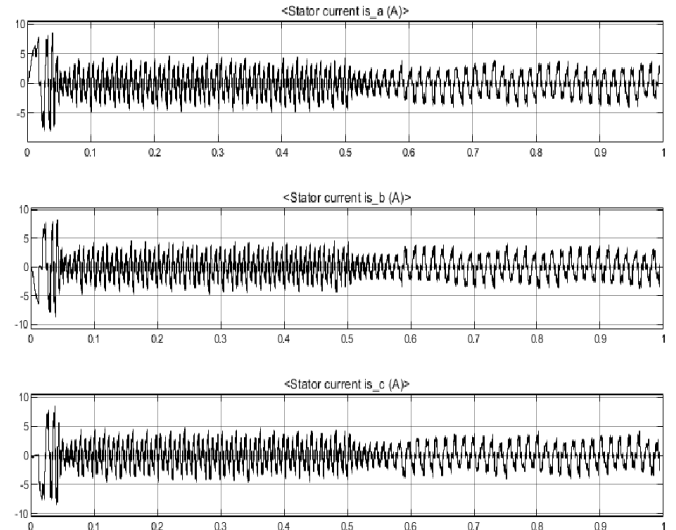

Fig 5- Output waveform of stator current

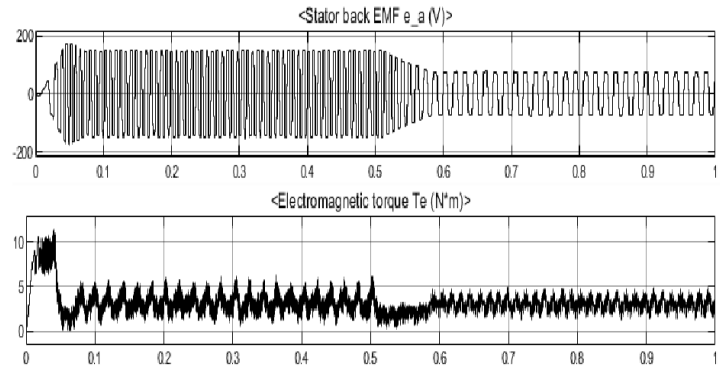

Fig 6- Output currents of Back EMF, Torque

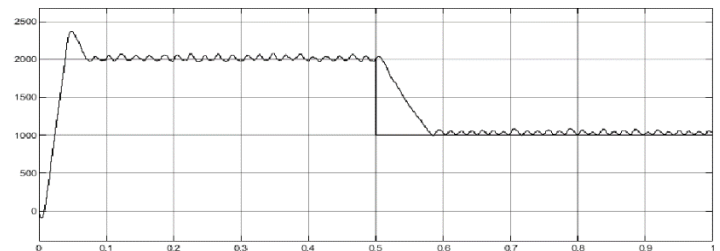

Fig 7- Speed characteristics using fuzzy controller

III. PROPOSED MODEL BLOCK DIAGRAM

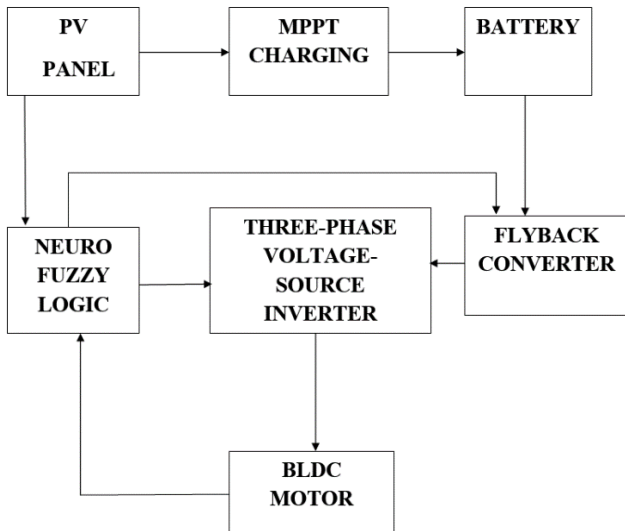

Fig 8- Block diagram of proposed model

Circuit explanation

The proposed methodology uses a concentrated solar module system connected to a flyback converter for ceiling fan use, powered by Brushless direct current motor. The electronic switching of the Brushless direct current motor regulates the switching frequency of the inverter, which reduces the inverter losses of the motor's high switching frequency power.

A. SOLAR PHOTOVOLTAIC ARRAY

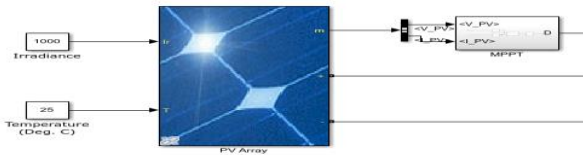

Fig 9- solar PV

B.MPPT USING BOOST CONVERTER

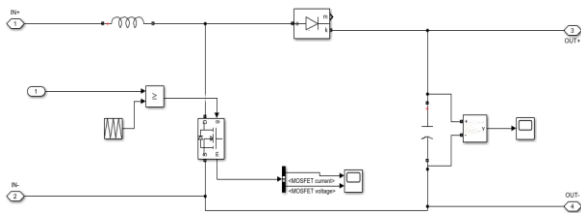

Fig 10- MPPT using boost converter

C.FLYBACK CONVERTER

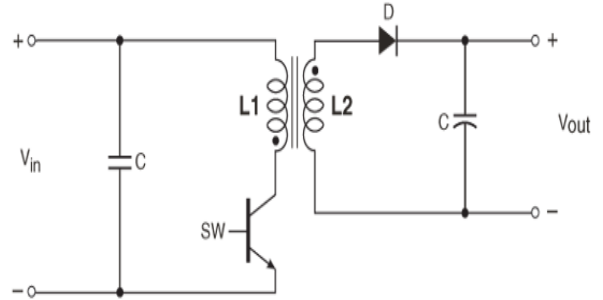

Fig 11- Flyback converter

The flyback converter is indeed a topology of the power supply that uses a mutually coupled inductor to store energy when current passes and release energy when power is withdrawn. The flyback converters are similar in design and efficiency to the Boost converters. Nonetheless, the transformer's main winding replaces the inductor, while the secondary one provides the output. The main and secondary windings are used as two different inductors in flyback configuration.

Advantages

- The main winding remains isolated from the output.
- Able to supply multiple output voltages, all disconnected from the main.
- Power to control the different output voltages with one control.
- It will perform at any wide range of input voltages.
- Compared with some other SMPS types, the Flyback converters often use few components.

D.NEURO-FUZZY LOGIC CONTROLLER

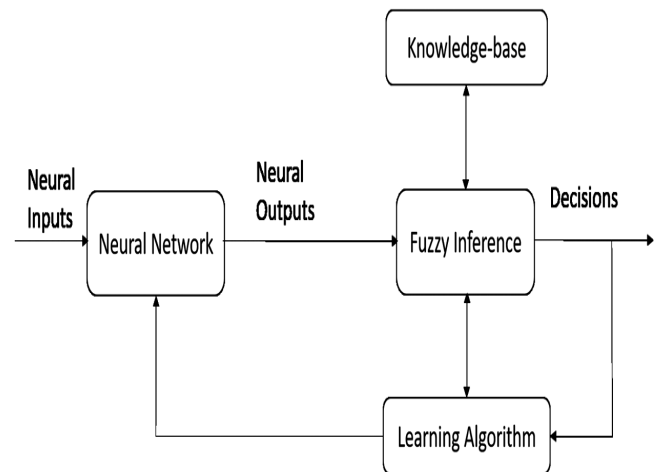

Fig 12- Neuro fuzzy system

Neural fuzzy systems are distinguished by the use of neural networks to have a sort of automated tuning mechanism for fuzzy systems, even without adjusting the functionality.

Though two types of neuro-fuzzy system exist

1. Mamdani approach.
2. Takagi & Sugeno's approach.

Mamdani-based neuro-fuzzy approach and layers are input layer, fuzzification layer, AND layer, fuzzy layer, defuzzification layer.

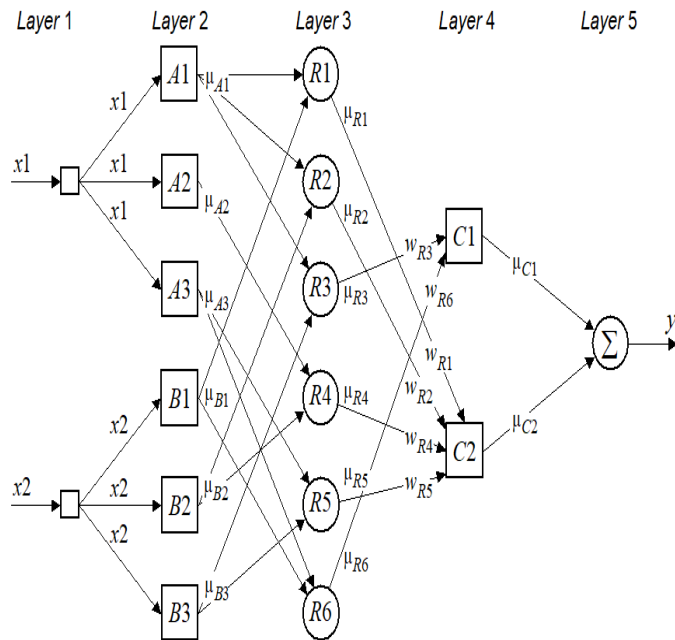

Fig 13- Layers of neuro fuzzy system

IV. SIMULATION OF A PROPOSED MODEL

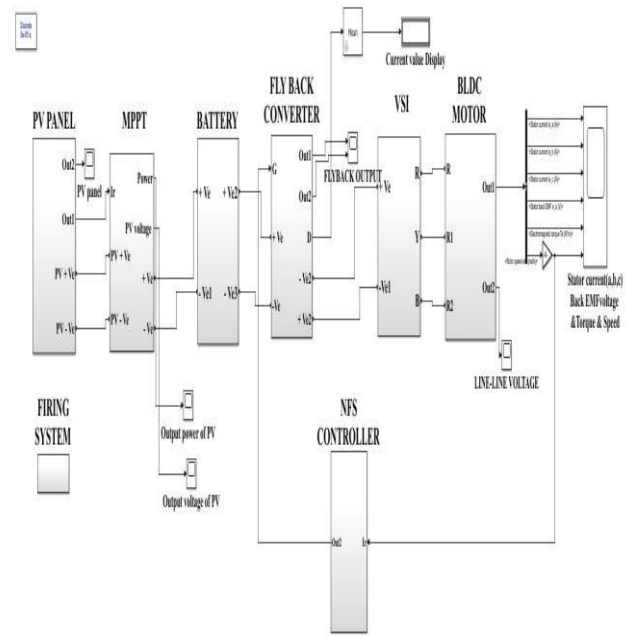

Fig 14- Simulation of a proposed model

A. SIMULATION WAVEFORMS OF PROPOSED MODEL

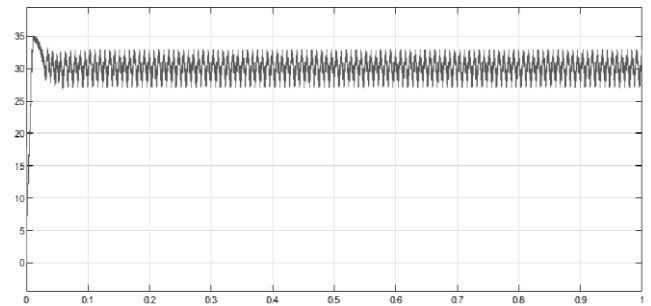

Fig 15- solar PV output waveform

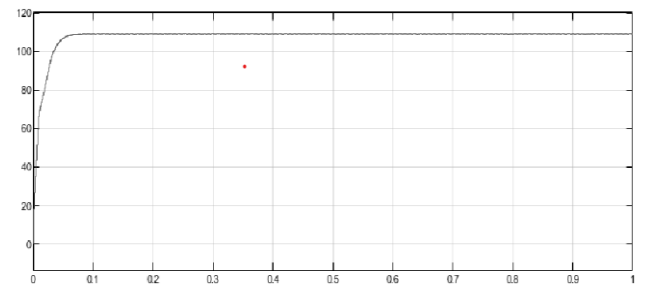

Fig 16- mppt waveform

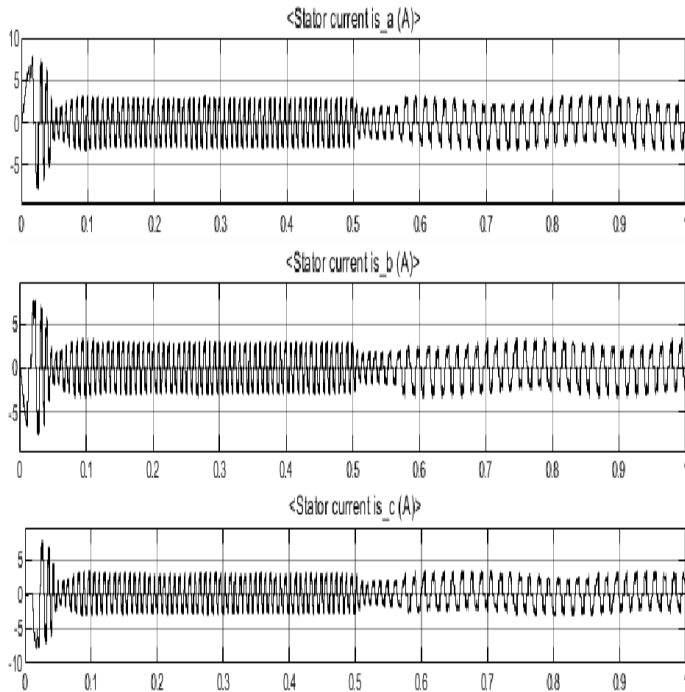

Fig 17- stator current waveforms

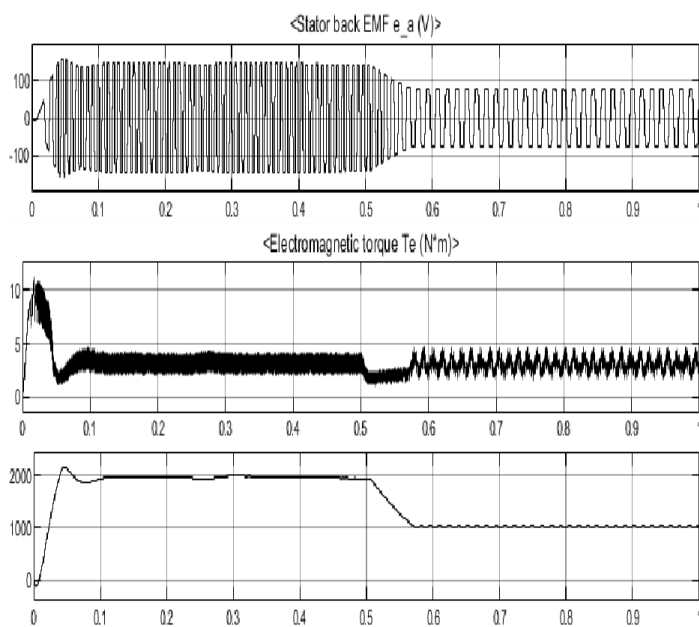

Fig 18- Back EMF, Torque and speed waveforms

Figure 18 and display the output characteristics of the neuro-fuzzy logic controller. Here, the step response is reduced at $t=0.5s$. The torque stays steady, and the stator current and speed output are steadily variable.

V. FUTURE SCOPE

The induction motor fans can be replaced by BLDC fans in the future because the power consumption in the BLDC fan is small compared to the induction motor fan. Through the use of the solar panel (PV), the BLDC fan can run directly on DC power without converting devices. Though a simulation was created in this project. There's still room for more improvement. Thus the proposed simulation model can be implemented with hardware.

VI. CONCLUSION

MATLAB Simulink software has been used to test improved torque control response on flyback converter fed Brushless direct current motor with Neuro-fuzzy logic controller. The dynamic characteristics of the brushless direct current motor are compared and analyzed, such as speed, torque, stator current and back emf voltage of the brushless direct current motor. It is found that the brushless direct current motor output is improved by the Neuro-fuzzy logic controller as compared to the Zeta converter fed brushless direct current motor with Fuzzy logic controller.

VII. REFERENCES

- [1] Padmaraja Yedamale (2003) "Brushless DC Motor fundamentals", AN885, Microchip.
- [2] Agile systems, Edrive Magazine, (April 2005) "Advances in sensorless control of brushless DC motors".
- [3] Dr. Mahesh rao ,(2012) "Energy efficient Ceiling fans using BLDC motors- a practical implementation", Proc. of the Intl. Conf. on Advances in Computer, Electronics and Electrical Engineering.
- [4] Jianwen Shao, (2003) "Direct Back EMF detection method for sensorless BLDC Motor drives", MSCEE Thesis submitted to VPI, Blacksburg, Virginia, USA,.
- [5] Nagadeven, SoibTaib, K. S. Rama Rao, (May 28-29, 2007) "DSP Based Sensorless Control of A BLDC Motor with Direct Back EMF Detection Method International Conference on Control", Instrumentation and Mechatronics Engineering Malaysia.
- [6] A Saxena, (IEEE 2014) "Performance and cost comparison of PM BLDC motors for ceiling fan;power electronics , drives and energy systems".
- [7] F.Parasiliti, M.Viliani, (2014) "PM brushless direct current motor with exterior rotor for high efficiency household appliances", IEEE.
- [8] D.F. Akhmetov, Y. Dote, S.J. Ovaska. (2001) "Fuzzy neural network with general parameter



- adaptation for modeling of nonlinear time-series".
IEEE Trans. Neural Netw., 12(1), pp. 148–152.
- [9] C.T. Sun. (1994)“Rule-base structure identification in an adaptive-network-based inference system”.
IEEE Trans. Fuzzy Syst., 2(1), pp. 64–79.
- [10] Amit Kapil, Bhadja Satish (4-6July2016)
“Analysis of cogging torque reduction by increasing magnet edge inset in radial flux permanent magnet brushless DC motor”
ICPEICES- 2016.
- [11] B.R. Lin, (1997) “Analysis of neural and fuzzy control power electronics control” , IEEE proceedings SCI .Meas. Tech Vol. 144,NO.1,jan.pp25-33.
- [12] D. M. Erdman, (March 31,1987) “Control system, method of operating an electronically commutated motor, and laundering apparatus,” US Patent 4654566.
- [13] P. Pillay and R. Krishnan,(Nov. 1988)
“Modeling of permanent magnet motor drives,”IEEE Trans. Ind. Electron., vol. 35, no. 4, pp. 537–541,.
- [14] P.Pillayand R. Krishnan(1987),“Modeling simulation and analysis of a permanent magnet brushless dc motor drive," presented at the IEEE IAS Annual Meeting, Atlanta,.
- [15] K.S. Tang, Kim Fun Man, Guanrong, Sam Kwong., (August 2001) “An Optimal Fuzzy PID Controller”, IEEE Transactions on Industrial Electronics Vol. 48, No. 4, pp.757-765.

IJEAST

INTERNATIONAL JOURNAL
OF ENGINEERING APPLIED SCIENCE
AND TECHNOLOGY

ABOUT IJEAST

International Journal of Engineering Applied Science and Technology (IJEAST) is a peer-reviewed, open access journal that publishes high-quality research papers in the field of Engineering, Applied Science and Technology.

IJEAST aims to provide a platform for researchers, academicians, and professionals to share their innovative ideas, research findings, and practical experiences with the global scientific community.

FOCUS AREAS

- Engineering
- Applied Science
- Technology
- Innovation & Development
- Interdisciplinary Studies



PEER REVIEWED

All submissions are rigorously peer reviewed to ensure quality.



OPEN ACCESS

Free and unrestricted access to research for all.



GLOBAL REACH

Connecting researchers and professionals worldwide.



TIMELY PUBLICATION

We ensure a swift and efficient publication process.



For more information, visit our website
www.ijeast.com



INTERNATIONAL JOURNAL
OF ENGINEERING APPLIED SCIENCE
AND TECHNOLOGY

✉ editor@ijeast.com

🌐 www.ijeast.com

📍 India



2455-2143