



IJEAST

INTERNATIONAL JOURNAL
OF ENGINEERING APPLIED SCIENCE
AND TECHNOLOGY



VOLUME : 5 ISSUE : 3 Print / Issue Publication Date: 15-Sep-2020



ISSN : 2455-2143



DOI : 10.33564/IJEAST.2020.v05i03.102

Indexed In



WWW.IJEAST.COM

editor@ijeast.com



AN ARDUINO SENSOR-BASED APPROACH FOR DETECTING THE FOOD SPOILAGE

Arun Kumar G

Department of Electrical and Electronics Engineering
PSG Institute of Technology and Applied Research, Coimbatore, Tamil Nadu, INDIA

Abstract— With the technology evolution and dependency of the people on the smart phones and raising demands of easy and quick way of solving their day-to-day life tasks, it has become vital to have a technological control over the industrial and the domestic applications using IoT. This paper substantially deals with the emerging technologies alongside the internet of things using Arduino which by the way employs the script programming and also the sensors like MQ2 Sensor, moisture sensor, DHT sensor, Arduino UNO etc. We develop a food quality detecting technique, where the sensors will be associated along the Arduino. Refrigeration is one of the essential techniques for food storage that operates by lowering the reproduction rate of the bacteria present in the food. But at some situations, one may fail to notice the food items that are not used for a long-term storage inside it. This paper is employed to solve the food spoilage problem, with the sensor assistance to identify the spoilage by continuous sensing. Based on the freshness and quality of food, the food spoilage will be displayed to the user through an alert message that is sent to their registered mobile numbers.

Keywords— Arduino UNO, DHT sensor, Food quality, Gas sensor, Internet of Things, Moisture sensor

I. INTRODUCTION

Food being the main source of energy for the living beings, the food quality and safety has been the highest demand throughout the history. Technologies like Internet of things (IoT) connects anything at anywhere and anytime. By utilizing the IoT in the food supply chain (FSC), it helps to enhance the life quality by tracking and tracing the condition of the food and live by sharing the data obtained from the consumers. Currently, the entire application of the IoT technology in FSC is still in the initial stage and a huge distance for improvements. The food hygiene and safety is the major concern to prevent the food from wastage. The food quality must be monitored and also should be prevented from decaying and routing the atmospheric factors such as darkness, humidity and temperature. Therefore, by deploying quality monitoring devices at food stores the wastage can be minimized. These kind of quality monitoring devices check on the atmospheric factors that are capable of causing food decay. Previously, the atmospheric factors were controlled by the

techniques such as refrigeration, vacuum storage etc., the contamination of food shall occur in the process of production, but mostly caused because of inefficient food handling practices due to the inappropriate ambient conditions during the food transportation and storage. There are various factors that leads to food poisoning, like humidity and temperature changes. So that the monitoring system which is capable of measuring the humidity and temperature difference during the food storage and transportation is of prime importance. Currently, almost everyone is getting affected by the foods they consume daily, not because of the junk food, but also the canned vegetables, food products that are consumed in daily-life, since their oxygen, temperature, and moisture content varies from time to time, they do not offer great quality. As most of consumers only pays attention towards the data provided on the packets, such as, the quantity of ingredients that are used and the nutritional value, they are blindly risking on their health by ignoring the atmospheric conditions to which these packages are subjected. To ensure the safety of the food, at every stage of supply chain, it must be monitored. It employs the purpose of protection to the consumer health by maintaining the required ambient conditions that are essential for food quality maintenance. The analysis and performance of the routine measurements, aims at the changes detection does not guarantee in the nutritional quality of the food. For the purposes of policy analysis, trend forecasting, program evaluation and planning, the information are collected by monitoring and surveillance should be analyzed and sent to the decision makers in an appropriate format to be of real value. Distribution of data must be an interactive process. The foremost job of the monitoring and control systems is to monitor a particular activity to make certain that it rests in the desired manner. By using various electronic sensors monitoring can be attained. Further for the controlling purpose, these recorded values shall be used. The information that are obtained from the Arduino-based sensors will be compared to the desired values. If the readings of the sensor are found to be differing from the desired values, then the control circuit would come into action to influence the allotted activity to maintain it in the desired quality. We propose the use of this principle to build a system that can preserve the raw food materials. The smart food monitoring system is primarily aimed to monitor and control the food items and thus preventing it from the spoilage that may occur due to

climatic and atmospheric changes. Also the inappropriate storing of the food items shall lead to food wastage. Thus the Smart food monitoring system mainly focus on the safe food storage by monitoring and controlling numerous parameters that are affecting the food items. This monitoring system uses the storage units that are embedded with various Arduino-based sensors that will read the parameters that are affecting the quality of the food items. The Control circuits are designed to overcome the issue of unenviable food storage conditions are the important part of this proposal. This project proposes an IoT foundation for easing the monitoring of the food items, so that it do not get spoiled due to the atmospheric conditions during storage and transportation. Currently, the work is completed in terms of the sensor values that are recorded and a comprehensive research has been executed.

II. PROPOSED ALGORITHM

A. Block Diagram –

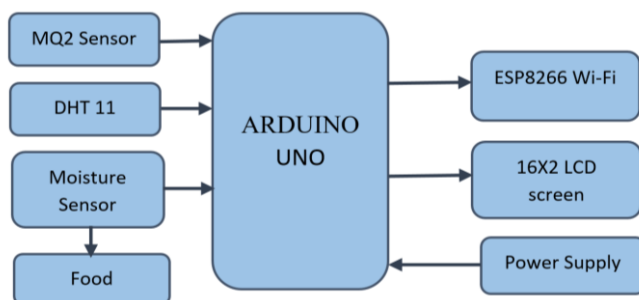

Fig. 1. Block Diagram of Arduino based food spoilage detector

B. Circuit Diagram –

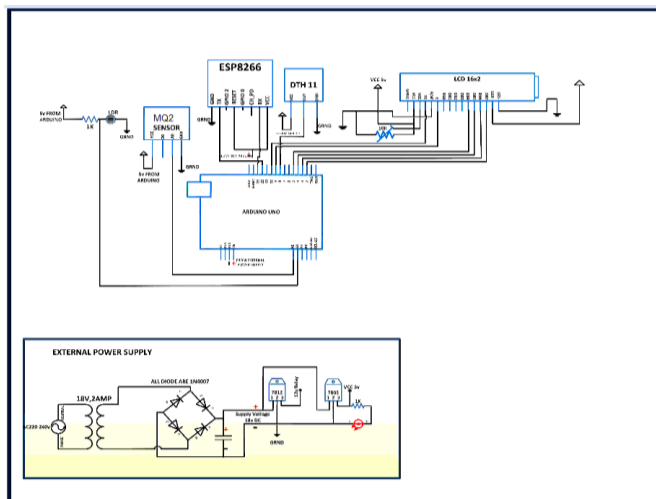

Fig. 2. Circuit Diagram of Arduino based food spoilage detector

C. Methodology –

A lot of people face the major problem of sustenance harming in their day to day life. The separation of nourishment waste

with the help of electronic and biosensors is the aim of this device. To keep away a significant issue, harming nourishment must be perceived ahead of schedule. The sensors that can distinguish different parameters of sustenance like pH, dampness, and ethanol level are used. The system comprises of a microcontroller Arduino Uno, Bluetooth module, electrical and biosensor like pH sensor, dampness sensor, and gas sensor. The nourishment should be placed inside the area of sensing range. After different sensors sensing, it is then compared with the comparing value which is already fed into the microcontroller. With the help of Bluetooth module, the client can receive information regarding freshness through Android portable application. A predefined calculation is fed into microcontroller and the readings from the sensor is compared. Based on sustenance freshness level, the output is displayed as "Great to utilize" or "Not great to utilize". In this venture, elements like temperature, moistness and liquor content will be constantly monitored by the system. As the system is based on Arduino UNO, it is an unmistakable prototyping board. Different sensors like DHT-11 to screen temperature and moistness, MQ2 to distinguish liquor content is linked with Arduino board. This is an IoT based system, sends necessary information to client/user. It is associated to the web by means of Wi-Fi switch, where ESP8266 Wi-Fi Modem (Node MCU) is interfaced with the Arduino. The IoT stage utilized for logging and checking of sensor information is IOT Watson. From anyplace, whenever, wherever and from any device, with the aid of Internet of Things, the sustenance stockpiling influenced by ecological component can be observed.

III. EXPERIMENT AND RESULT

Even before visible signs of decay such as mold or odor were to be observed, the Arduino based gas sensors were able to sense gases well and provide necessary information. The degree of spoilage of food was compared with the level of emissions of these 3 gases. As Arduino-based gas sensors are highly sensitive, even low amount of emissions of methane and ammonia can be detected/identified which is generated by decaying food. The levels of the gas emissions were very high (>20-fold) when visible signs of decay started to appear. Fruits produce better results when compared to other foods. Food products like rice and milk when tested provide much lower value of gases.

COMPONENTS REQUIRED:

1. Arduino UNO
2. ESP-8266 Wi-Fi module
3. GSM800
4. 16*2 LCD Display
5. DHT-11 Sensor
6. Ch4 Sensor
7. Light Sensor
8. Humidity sensor

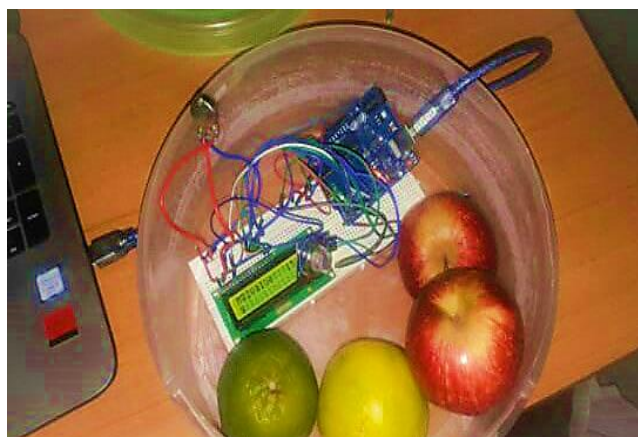

Fig. 3. Arduino based food spoilage detector

IV. ADVANTAGES

- With the help of this system, fruits and vegetables can be stored and used for longer time as the period of freshness can be determined.
- Clean and hygienic surrounding can be maintained.
- Analysis can be made with the help of data of food products saved in cloud.
- The system reduces the commercial loss and increases commercial profit.

V. FUTURE SCOPE

- Detection of alcohol level in food substance to expand the sensing fields.
- For application in liquid process food streams, inclusion of Nano-Detect process will be used to develop on-line and off-line monitoring systems (sensors) which combine the expertise of sensitive molecular biological processes with the potency of nanotechnology.
- Usage of high precision sensors to increase area of sensing.
- Integration of two or more sensors for foods which display dual parameters.
- Based on amount of calorie consumption a pressure sensor is included which helps to maintain a balanced diet.

VI. CONCLUSION

Detecting the naturally emitted gases such as Methane, Ammonia and Ethylene as food decay can be used to detect food spoilage. Even before the presence of any visible signs of spoilage, Arduino gas sensors are able to detect gas emissions from food items. Using sensors to detect the presence of these gases among foods can help detect food spoilage early and prevent consumption of spoiled food. Different types of

sensors can be linked to further extend the usage of system and to increase the sensitivity of such detection methods.

VII. REFERENCE

- [1] Yousefi H., Ali M M., Su H M., Filipe C D., and Didar T F.(2018). Sentinel wraps: Real-time monitoring of food contamination by printing dnazyme probes on food packaging. *ACS Nano*, (pp. 3287–3294)
- [2] Min C., Jiafu W., and Fang L. (2012). Machine-to-machine communications: Architectures, standards and applications. *KSII Trans. Internet Inf. Syst*, (pp. 480–497)
- [3] Wisitsoraat A., Tuantranont Comini E., Sberveglieri G., and Wlodarski W. (2009). Characterization of n-type and p-type semiconductor gas sensors based on NiOx doped TiO2 thin films, *Thin Solid Films*, (pp. 2775–2780)
- [4] Abdullah M Z., Aziz S A., and Dos Mohamed A M. (2000). Quality inspection of bakery products using a color-based machine vision system, *Journal of Food Quality*, (pp. 39–50)
- [5] Syeda Erfana Zohora A M., Khan A K., Srivastava A. (2013). Electronic Noses Application to Food Analysis Using Metal Oxide Sensors: A Review, *Journal of Soft Computing and Engineering*, (pp. 79–84)
- [6] Chanthini B., Manivannan D., and Umamakeswari A. (2017). Perishable Food Quality Monitoring – An Internet of Things (IoT) Approach, *International Journal of Pure and Applied Mathematics*, (pp. 63– 67)
- [7] Sazonov E., and Fontana J M. (2011). A sensor system for Automatic detection of food intake through non-invasive monitoring of chewing, *IEEE Sens.J*, (pp. 1340– 1348)
- [8] Wang J., Nakano K., Ohashi S., Kubota Y., Takizawa K., and Sasaki Y. (2012). Detection of external insect infestations in jujube fruit using hyperspectral reflectance imaging, *Biosystems Engineering*, (pp. 345–351)
- [9] Arghya Sett., Suradip Das., Pragya Sharma., and Utpal Bora. (2012). Aptasensors in Health, Environment and Food Safety Monitoring, *Open journal of applied biosensor*, (pp. 9–19)
- [10] Ashish Kumar Singh., and Neelam Verma. (2014). Quartz Crystal Microbalance Based Approach for Food Quality, *Current Biotechnology*, (pp. 127– 132)
- [11] Venkatesh A., Saravanakumar T., Vairamsrinivasan S., Vigneshwar A., and Santhosh Kumar M. (2007). A Food Monitoring System Based on Bluetooth Low Energy and Internet of Things, *Int. Journal of Engineering Research and Application*, (pp.30– 34)
- [12] Sumathi M S., Thejaswini S., Pranav Kashyap., Shahina Anjum., Shashi Shanker., and Shreya G K. (2011). IoT based project for food quality and monitoring, *International Journal on Recent and Innovation Trends in Computing and Communication*, (pp. 3172 – 3174)



- [13] Kong Xiansheng., and Sun Jing. (2014). Design and implementation of food intelligent monitoring system based on pH sensor, China Journal of Chemical and Pharmaceutical Research, (pp. 1662– 1666)

IJEAST

INTERNATIONAL JOURNAL
OF ENGINEERING APPLIED SCIENCE
AND TECHNOLOGY

ABOUT IJEAST

International Journal of Engineering Applied Science and Technology (IJEAST) is a peer-reviewed, open access journal that publishes high-quality research papers in the field of Engineering, Applied Science and Technology.

IJEAST aims to provide a platform for researchers, academicians, and professionals to share their innovative ideas, research findings, and practical experiences with the global scientific community.

FOCUS AREAS

- Engineering
- Applied Science
- Technology
- Innovation & Development
- Interdisciplinary Studies



PEER REVIEWED

All submissions are rigorously peer reviewed to ensure quality.



OPEN ACCESS

Free and unrestricted access to research for all.



GLOBAL REACH

Connecting researchers and professionals worldwide.



TIMELY PUBLICATION

We ensure a swift and efficient publication process.



For more information, visit our website

www.ijeast.com



INTERNATIONAL JOURNAL
OF ENGINEERING APPLIED SCIENCE
AND TECHNOLOGY

✉ editor@ijeast.com

🌐 www.ijeast.com

📍 India



2455-2143