



IJEAST

INTERNATIONAL JOURNAL
OF ENGINEERING APPLIED SCIENCE
AND TECHNOLOGY



VOLUME : 7 ISSUE : 10 Print / Issue Publication Date: 17-Apr-2023



ISSN : 2455-2143



DOI : 10.33564/IJEAST.2023.v07i10.009

Indexed In



WWW.IJEAST.COM

editor@ijeast.com



AN ARTIFICIAL INTELLIGENCE-BASED SPEAKING SYSTEM FOR DUMB PEOPLE

Chilupuri Anusha, N Krishna Jyothi
Department of ECE
G. Narayanamma Institute of Technology and Science,
Hyderabad, Telangana, India

Abstract— For deaf-mute people all around the world, Gestures are the main mode of communication for Deaf-Mute people worldwide. In this gesture-based voice system, machine learning presents a real-time vision-based system for monitoring hand finger gestures. It was developed in Python using Raspberry Pi along with a camera module, which is compatible with the Open CV library for computer vision. The Raspberry Pi includes an image processing technique that monitors the fingers of the hand using the extracted attributes. The main purpose of a gesture based speaking system is to develop control communication between humans and computers. This leads to a system that can recognize and monitor known objects and has surveillance and application capabilities. The major goal of the suggested work was to allow the system to function properly. The main objective is to enable the system to recognize and monitor certain properties of objects specified by the Raspberry Pi along with camera module using an appropriate image processing technique. The Open CV library's feature extraction technique of the Open CV library for Python programming runs on Raspberry Pi using an external camera. A gesture based speaking system using machine learning provides a new, intuitive, and simple way to communicate with computers that are more human-like.

Keywords— Machine Learning, Keras, Sequential Model, Raspberry pi, Camera

I. INTRODUCTION

Pattern recognition and moving robot navigation are two applications of vision-based and image processing systems respectively. The fundamental activity in computer vision is object tracking, and extracting the features of the object, which can be used to control the traffic, interaction between humans and computers, gesture detection, augmented reality, and surveillance. Higher-level picture tasks will perform best with an efficient tracking technique. A surveillance system has been employed by people all over the universe to aid them in securing territory or specific locations. It led to the development of a surveillance system with applications for detecting and monitoring a known object.

The main goal of the work is to create a system utilizing a Raspberry Pi and a camera module that can detect and monitor

specific features of the gesture images that are specified according to image processing techniques. The feature extraction technique was written in Python and tested on a Raspberry Pi with an external camera using OpenCV libraries. Even in low-light situations, this system performs admirably. A Raspberry Pi-based hand gesture algorithm is utilized to drive a mobile robot, resulting in a vision-based system that depend on human-machine interaction.

The present work is organized as follows. Literature Survey, Objectives, Proposed System, Implementation of the system, methodology, results and conclusions.

II. LITERATURE SURVEY

In most cases, communication between disabled and non-disabled people utilizes the form of synthesized speech, also known as sign language. Information is transformed into voice commands with the help of flex sensor and an Arduino Mega 2560, allowing disabled people to communicate with normal people [1]. In case of an emergency, the user's present location can be followed using GPS, and a text message can be sent to the guardian via GSM module. However, most people do not comprehend sign language, a new method based on vision is being developed. The system complexity grows in the proposed system, requiring picture extraction and categorization [2]. Different studies are being conducted to assess and evaluate how the device can help people with hearing and speech disabilities communicate more effectively, as well as to determine the device's limitations in contrast to other technologies and devices pursuing a similar goal. Their only means of communicating with others is through hand motions and expressions, and they have created a prosthetic speaking mouth for deaf people. This will also assist others in comprehending people with disabilities [3]. For silent patients, a device has been developed that uses flex sensors to translate the twisting movement of the fingers into a voice. When spoken through a speaker, the messages are displayed on the LCD [4]. Another solution to the same problem is given by utilizing hand gloves that translates any sign language to a globally recognized language such that any person who can read and write may understand the disabled people [5] [6]. Several writers have discussed and created a prototype model using expensive sensors such as the Kinect V2 sensor and the leap motion controller, with an 89.5 percent recognition accuracy [7]. The next generation of glove devices results in

technical developments in computation, more powerful, more adaptable as sensor & actuator devices, materials, and processing/classification techniques [8] [9].

Sign language is a method of communication for deaf and hard of hearing persons. It has been noted that people with disabilities have a tough time interacting with society. Normal people are unable to comprehend their sign language. The proposed system functions as a bridge between disabled and normal persons to close this gap. So, using machine learning methods, a system is created that captures the gesture and outputs a speech command.

III. OBJECTIVES

The Hand gesture recognition system using machine learning should be able to identify the hand from other objects before moving on to image classification and it should capture the hand gesture. From the captured images, data set is prepared using Keras to train the sequential model. To make a model for hand gesture recognition system which can recognize gestures and display text and speech output utilizing a computer vision library (Open CV) and a Sequential Neural Network.

IV. PROPOSED DEVICE

The proposed system runs on a Raspberry PI and is said to use a camera module for image capture. To capture the images camera module, is used, which are stored in the gesture data set for processing feature extraction using sequential model. The extracted features are categorized, then the gestures are recognized, and the corresponding text displayed on LCD and voice command as an output from speaker. Abstract representation of raspberry pi-based Gesture recognition system and schematic of Gesture based speaking system is shown in Fig.1 and 2.

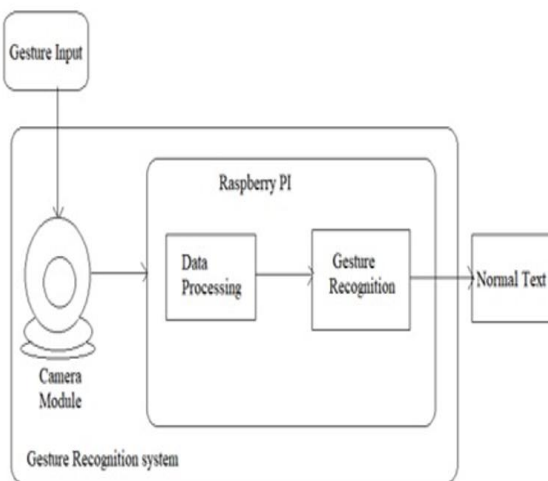

Fig. 1. Abstract Representation of Gesture Recognition System

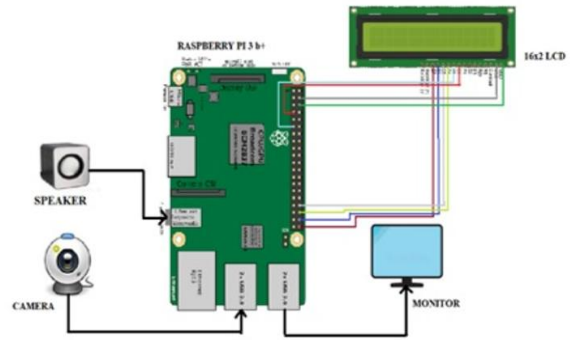

Fig. 2. Schematic of Proposed device

A. Implementation

This system is developed in python language using multiple libraries like Open CV, NumPy, Matplotlib, TensorFlow and Keras for data processing, model building and testing. Flowchart for developing a system is shown in Fig. 3.

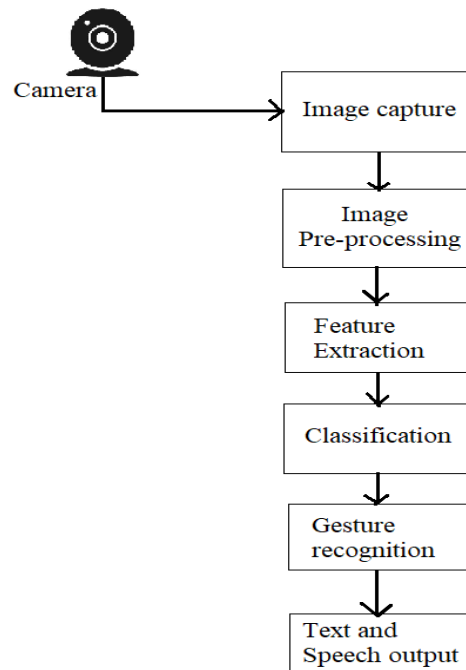

Fig. 3. Flow diagram of Proposed device

Various steps are involved in sign language gesture recognition [10]. First, placing hand in-front of the camera in order to recognize the fingers and capture the images. For this system uses a webcam of 30MP resolution [11]. Store the captured images in database, which further use for training and testing. Before training the system, images are pre-processed which involves Image Acquisition, Image Analyzing and Manipulation which extracts the information from digital images [12]. After pre-processing the images, feature extraction is done to reduce the amount of redundant

data from the data set which speed up the training process. Further Classification is also involved, where a class label is predicted for a given input data. For, Gesture Recognition, by keeping hand in front of camera and the system captures the images and tests if it is matching with the input data or not. If it is there then it will recognize the image and gives us the output. After recognizing the fingers, output in text displayed on LCD and voice through speaker which is connect to the Raspberry Pi.

B. Methodology

Preparing Dataset

The hand gesture recognition system using machine learning uses a dataset, to identify the static gesture, to train the system and to classify gesture. In this work first preparing our own dataset model with 16 gestures, and calling it from keras using the command “model = keras. models. load_model (r"best_model.h5")”. The camera module captures the image and the image is saved in the dataset which contains the threshold images of all the gestures and for each gesture 650 images are captured. The captured threshold images are shown in fig. 4.

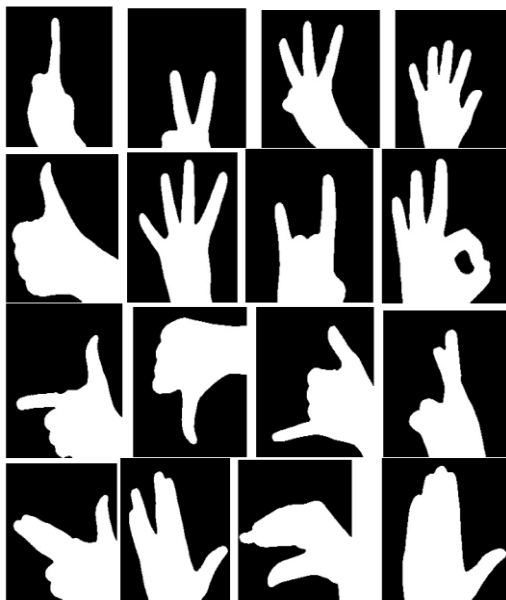

Fig. 4. Input Threshold Images

C. Training Testing and Evaluation

Ten epochs (iteration over the entire data provided) are used to compile the model and fitting it to the training data. Next to evaluate the loss and any model metrics at the end of each epoch data is validated on which the model is trained. As metrics = [‘accuracy’] the model will be evaluated based on the accuracy. For training we are using 500 samples of each gesture and for testing we are using 150 samples of each gesture.

Sequential model was chosen to train the model in this work is shown in Fig.5. The model was trained with features extracted for 10 iterations/epoch with ReLU/Tanh and SoftMax activation functions used for non-linear function. The usage of the ReLU activation function is to remove the negative input and make it 0 and to keep the positive input value as it is.

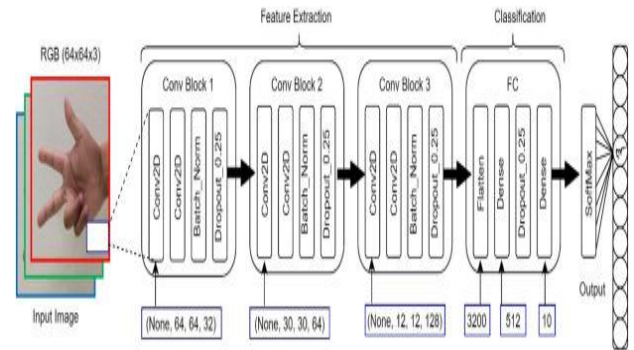

Fig. 5. Sequential Model for Training

This model is trained and tested using samples in the dataset for accuracy and the loss. The model is trained with the prepared dataset and was evaluated during the process of testing. Once the model got trained, testing is done.

III. EXPERIMENT AND RESULT

A reliable and efficient sign language speaking system using machine learning technique is designed to help the persons hard to hear and speak. In this work, 16 different gestures, for each gesture 650 images were taken, among that 85% have been taken to train the model and 15% was used to test the model, and successfully implemented which gives a voice command through speaker and corresponding message gets displayed on LCD, with an accuracy of 91%. This helps a speech-impaired person to express their needs using hand gestures. Thus, this model has made easy to understand the actions of the dumb people and providing the output in the form of voice and text which avoids the gap between the speed impaired people and the normal people. Further in this system the voice output can be manipulated in any language according to the user's need and the model can be trained and tested accordingly. The output results are shown in Fig. 6.



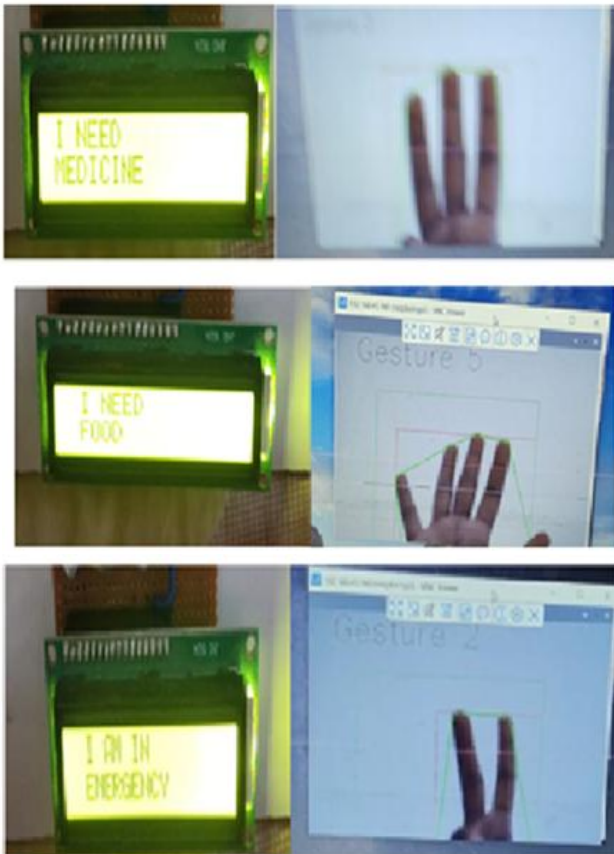

Fig. 6. Displaying Voice command on LCD Screen based on Gesture

IV. CONCLUSION

The proposed system was succeeded in detecting the hand and giving the text and voice output. The performance of machine learning algorithm is assessed based on the recognition of hand gestures. The novelty of the system is using our own data set of 16 different types of hand gestures. The results shown that this system can be used for detecting and recognition of hand gesture of human by least computer interaction technique. The hand gesture speaking system using machine learning is implemented efficiently using a raspberry pi along with camera module and developed in Python programming language using required OpenCV libraries. It can be introduced as a new and modern method for hand gesture speaking system that does not depend on traditional sensors (flex, IR, or Ultrasonic). Further thought of developing it with different states and countries sign language with different language as voice and text output.

V. REFERENCE

[1]. Meghana A S, Niveditha M, Prathibha K, Raksha G R, H C Sateesh Kumar, "Smart Speaking Glove For Speech Impaired People," International Research Journal of Engineering and Technology, vol. 6, no. 6, pp. 830-836, June 2019.

[2]. S.K. Imam Basha, S.Ramasubba Reddy, "Speaking System to Mute People Using Hand Gestures," International Research Journal of Engineering and Technology, vol. 5, no. 9, pp. 238-41, 2018.

[3]. Pallavi Nagarkar, Pravar Chaturvedi, Bhumika Neole, "Hand Gesture Speaking Unit for Mute People," International Journal of Computer Sciences and Engineering, vol. 7, no. 4, pp. 532-35, 2019.

[4]. Bachkar Y. R., Gupta A.R. & Pathan W.A. , "Smart Speaking Gloves for Speechless," IOSR Journal of Electronics and Communication Engineering, pp. 10-14.

[5]. Deepak Dhuri, Aditya Gaushal, Roshan Sawant, Tanaji Renose, Mrs. Mansi Kolwankar, " Speaking Hand using Raspberry pi 3," International Journal of Trend in Scientific Research and Development , vol. 2, no. 3, pp. 768-70, 2018.

[6]. S.Madhumitha, Neeraja S. Sathya, Pravya Pinto, Riyan John Stephan, "A Novel Method for Recognizing Sound of the Silent through Gestures-Sign Language Interpreter," International Journal of Advanced Research in Electrical, Electronics and Instrumentation Engineering, vol. 3, no. 5, pp. 9646-51, 2014.

[7]. Ujwala D Rode, Manali D Sonar,Stela R. Wavikar, Veenaya P Salve. , "Sign SignRecognition for Dump and Deaf people using Android App," Spvryan's International Journal of Engineering Sciences & Technology, vol. 2, no. 5, pp. 1-4.

[8]. Sudheesh Narayanan1, Tijomon C. K, Pramod Thankachan, Vishnu Chandran,Divya M. Kaimal, "Communication Aid With Home Automation For Deaf Dumb," International Journal of Research in Engineering and Technology, vol. 4, no. 3, 2015.

[9]. Deepak Sharma, Kenil Vora and Shivam Shukla. , "Hand Assistive Device for Deaf And Dumb People," International Journal of Advanced Research, pp. 1042-46, 2017.

[10]. Lionel pigou et al., "Sign Language Recognition using Convolutional Neural Networks," in Ghent University, ELIS, Belgium.

[11]. Senthilkumar, G., K. Gopalakrishnan, and V. Sathish Kuma, "Embedded image capturing system using raspberry pi system," International Journal of Emerging Trends & Technology in Computer Science , vol. 3, no. 2, pp. 213-15, 2014.

[12]. Ali A. Abed, Sarah A. Rahman, "Computer Vision for Object Recognition and Tracking Based on Raspberry Pi," in International Conference on Change, Innovation, Informatics and Disruptive Technology ICCIIDT'16, london,UK, 2016.

IJEAST

INTERNATIONAL JOURNAL
OF ENGINEERING APPLIED SCIENCE
AND TECHNOLOGY

ABOUT IJEAST

International Journal of Engineering Applied Science and Technology (IJEAST) is a peer-reviewed, open access journal that publishes high-quality research papers in the field of Engineering, Applied Science and Technology.

IJEAST aims to provide a platform for researchers, academicians, and professionals to share their innovative ideas, research findings, and practical experiences with the global scientific community.

FOCUS AREAS

- Engineering
- Applied Science
- Technology
- Innovation & Development
- Interdisciplinary Studies



PEER REVIEWED

All submissions are rigorously peer reviewed to ensure quality.



OPEN ACCESS

Free and unrestricted access to research for all.



GLOBAL REACH

Connecting researchers and professionals worldwide.



TIMELY PUBLICATION

We ensure a swift and efficient publication process.



For more information, visit our website

www.ijeast.com



INTERNATIONAL JOURNAL
OF ENGINEERING APPLIED SCIENCE
AND TECHNOLOGY

✉ editor@ijeast.com

🌐 www.ijeast.com

📍 India



2455-2143