



IJEAST

INTERNATIONAL JOURNAL
OF ENGINEERING APPLIED SCIENCE
AND TECHNOLOGY



VOLUME : 6 ISSUE : 5 Print / Issue Publication Date: 04-Dec-2021



ISSN : 2455-2143



DOI : 10.33564/IJEAST.2021.v06i05.010

Indexed In



WWW.IJEAST.COM

editor@ijeast.com



DESIGN AND FABRICATION OF A SMALL SCALE COCOPEAT COMPACTION MACHINE

Evans Magara
Faculty of Engineering and
Technology,
Multimedia University,
Kenya
P. O. Box 15653-00503,
Mbagathi, Nairobi.

Abel Mayaka
Faculty of Engineering and
Technology,
Multimedia University,
Kenya
P. O. Box 15653-00503,
Mbagathi, Nairobi.

Charles Ondieki
Faculty of Engineering and
Technology,
Multimedia University,
Kenya
P. O. Box 15653-00503,
Mbagathi, Nairobi.

Bernard Ikua
School of Mechanical
Engineering, JKUAT,
Kenya
P.O. Box 62000-00100
Nairobi, Kenya

Abstract - Coconut is one of the major crops grown by small-scale farmers in Kenya coast. This crop has a great potential to contribute to the economy of the region, owing to the wide applications of its products. Virtually all parts of the crop including its leaves, fruit, stem and roots are useful for many products, such as food, beverages, cosmetics, medicine, furniture, textiles and cocopeat. Cocopeat is a by-product in fibre production from coconut husks. The cocopeat is used as a planting medium in soilless culture in agricultural production and as a soil substitute in containerized crop production. Recently, these soilless media have received much interest especially in commercial applications in Kenya, especially in horticultural farms. Since the cocopeat is a loose material, its transportation poses a challenge due to its bulkiness. Therefore a need for compacting it for ease of transportation. For this purpose, an automated cocopeat block making machine was developed to compact the loose cocopeat into uniform blocks to facilitate stacking and ease of transportation from source to agricultural farms across the country. The machine was automated.

Key words: *Cocopeat, design, fabrication, Density, Compaction.*

1. INTRODUCTION

In the coastal counties of Kenya, many small scale farmers rely on the coconut crop for their livelihood. Kenya has 436,634 acres of land under coconut cultivation with a tree population of 9.9 million producing over 246 million mature nuts annually (Agriculture and Food Authority, 2019). The estimated potential of the coconut industry stands at KES 25 billion annually with the current exploited monetary value at KES 12.2 billion which is only 48.8% of the estimated potential. This is attributed to the under-developed coconut value chain in Kenya.

According to the Economic survey report of 2019 (Kenya Bureau of Statistics, 2019). Kenya produced 107,000 metric tons of coconut and imported 1,000 metric tons of coconut, this made a domestic supply of 108 metric tons in 2018. All this was used for domestic consumption as food, none was processed, used as feed or seed for replanting.

In 2017, Kenya produced 124,000 metric tons of coconuts of which 10,000 metric tons were used as feed, 34,000 metric tons processed, and 72,000 metric tons as

food while 8,000 metric tons went to waste. The Kenya Government estimates that the coconut sub-sector can contribute 4.5 percent of the Agricultural Gross Domestic Product (GDP) and 1.2 per cent of the national GDP at its full potential according to the Economic Survey Report of 2018 (Kenya National Bureau of Statistics, 2018). Despite the high coconut production rates, the sector is faced with many challenges that have made it not to realize its full potential. These challenges include: excessive harvesting of old coconut orchards, lack of proper storage facilities for harvested coconuts, lack of technologies for mass production, lack of machines in the coconut value chain to assist in coconut processing, lack of trained personnel to operate the processing machines, declining markets for traditional coconut products, limited research on ways to improve the coconut value chain and the exploitation of coconut farmers by middlemen in the value chain. These challenges have led to the development of coconut processing machines in the country, their design, manufacture, fabrication and performance evaluation, to realize maximum benefits in both products and by-products in the coconut value chain to improve the income levels of farmers in coconut growing areas in Kenya.

The demand for coconut products over time has decreased and this has necessitated the need to look for other profitable markets for the products. This requires stakeholders to bring the existing coconut industry to higher level in the development of the coconut value chain possibly by adding value. One way to do this is to use technology in the extraction of fiber (Krishnamurthy, Maheswari, Udayarani, & Gowtham, 2009). In the extraction of fiber, cocopeat is produced as a by-product. Cocopeat is used in agriculture as a growing medium for high value crops and in the propagation of seedlings, as it has conducive properties for growth and propagation (Fernando & Amarasinghe, 2017).

Cocopeat as a growing medium is becoming popular worldwide. It serves as a substrate for hydroponics and growing mixes in agriculture (Shiva, Anandkumar, & Naorem, 2017). For ease of transportation to the agricultural sites, the bulky cocopeat needs to be compacted or densified. Compaction technologies, classified as high-pressure compaction, medium pressure compaction and low-pressure compaction with binder are used in compaction. Currently the compaction and densification technologies include the screw and ram, and the piston



compaction. Ram and piston presses and screw extrusion presses are used for compaction in high- pressure compaction. The compacted products in this case are completely solid, the screw press compacted blocks have a concentric hole giving them better compaction characteristics due to the larger specific area created (7).

Compaction is the pressing of particles together in a confined volume. The fine materials, which deform under high pressures, need no binders when pressed. Valence forces, interlocking forces or the van der Waals forces influence the compaction characteristics of the blocks. The prevailing high-pressure forces act on the natural components of the compressed material to become binders although some material still may need binders even under high pressures conditions (Lardinois & Klundert, 1993).

Compaction makes transportation of cocopeat easier, and thus, the development of cocopeat compaction machines is essential for the agricultural sector. The compacted blocks must have the right compaction characteristics to avoid breakages during transportation. Press pressure and cocopeat moisture content are critical for the achievement of the the required characteristics (Agriculture and Food Authority, 2016).

The purpose of this research is to develop a simple and efficient cocopeat compaction machine for use by small scale coconut farmers.

1.2 Problem statement.

The coconut sub-sector demonstrate an immense potential to drive the economic development in the coconut growing areas. This potential is far from exploited as only 48% of the estimated potential is exploited (Khurmi R & Gupta, 2005). This high potential of the coconut sector in Kenya necessitated a re-look at the coconut value chain to realize its full utilization. In the coconut value chain, cocopeat transportation to agricultural firms is difficult due to its bulky and spongy nature therefore the need to compact it into blocks of optimum density for ease of transportation. The cocopeat compaction machines available for this purpose and in small-scale use in the country are manual with no data relating to their maintenance, operation and performance. On the other hand, the machines in industrial use are powered, automated, and efficient and have high production rates (Zion, Rackielyn, & Mirafel, 2019). These automated machines are expensive for small-scale use in terms of purchase, maintenance and operation. Thus, the need to develop a low cost locally- fabricated and automated cocopeat compaction machine that is efficient, accessible and easy to operate for small-scale use in the country.

1.3 RESEARCH OBJECTIVES

- 1) To carry out analysis of cocopeat compaction machines.
- 2) To design a machine for compacting cocopeat.
- 3) To fabricate a machine for compacting cocopeat.

1.4 RESEARCH MATERIALS AND METHODS

The research material used was cocopeat from cocogrow Ltd. Developmental research design was used. Analysis of

existing compacting machines was done, then design of the compacting machine which followed the following guidelines, preliminary research, machine design considerations, design concept development, compaction machine fabrication and automation and testing. The machine design considerations were, cost of machine developed, size of the blocks produced, strength and availability of the materials used, rigidity of the system, operation and safety considerations. The equipment used are the universal drilling machine, lathe machine, welding machine, power saw, hammer, and digital electronic balance, pressure gauge, moisture sensor and hand gloves. These equipment were at Mechanical laboratory at multimedia University of Kenya where the design, fabrication and testing was done.

1.5 Analysis of Cocopeat Compaction Machines

The cocopeat block making machines in the market are categorized as manual and automatic machine. An analysis was carried out on cocopeat compaction machines and the results tabulated as below.

Table 1: Analysis of Cocopeat Compaction Machines

Manual machine	Semi-automatic machine	Automated machine
Do not use any form of hydraulic system	Use hydraulic system	Use hydraulic system
Do not use electricity	Use electricity	Use electricity
Have significantly low maintenance costs	Moderate maintenance cost	High maintenance cost
Require minimal skills to operate	Some operations require skilled labour	Require high skilled labour to operate
All operations are by hand	Some operations are by hand	All operations are automated
Are cheaper compared to automated machines	Relatively cheaper that automated machines	Are expensive compared to manual machines
Are simple in design and suitable for small scale use	Are somehow complex in design and used for medium usage	Complex in design and suitable for large industrial use
Have low production rates	Medium production rates	High production rates
Operators become fatigued quickly for continuous operations	Operators become fatigued over time	Operators are not fatigued for continuous operations
Non uniform blocks are produced	Uniform blocks are produced	Uniform blocks produced

produced		
Inefficient	Relatively efficient	Efficient
Manually operated	Semi-automatic	Automatic
Low productivity (20 blocks per hour)	Medium productivity (100 blocks per hour)	High productivity 300 blocks per hour
Brick size (L x W x H); Not uniform	Brick size (L x W x H); 30 x 30 x 10 cm, uniform	Brick size (L x W x H); 30 cm x 30 cm x 10 cm
Compaction ratio, not uniform	Compaction ratio 5:1	Compaction ratio, 6:1
Cost Ksh. 90,000	Cost Ksh. 3,063,554.02	Cost Ksh. 10,421,990.00

Yields strength σ_y shear	145 Mpa
Modulus of elasticity (E)	200 Gpa
Modulus of rigidity	77.2 Gpa
Density (ρ)	7860 Kg/m ²
Coefficient of thermal expansion	11.7 Gpa

Determination of Yields stress

Maximum allowable stress = yield stress point/ Factor of safety

2.3 Design of Machine components

Frame

The frame is the housing of the machine. It is divided into the front and rear section. The front section houses the mold and the compactor, has guides for the mold and compactor and it also has the compacting plate while the rear side has the mixing chamber, motor and the pulley.

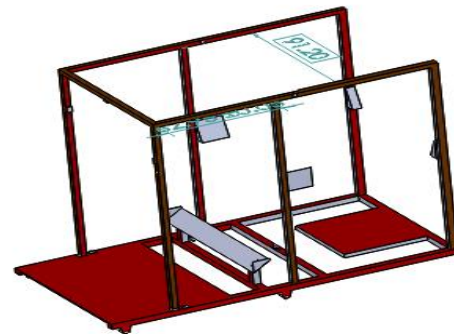

Plate 3: Frame

II. DESIGN OF AUTOMATED COCOPEAT COMPACTION MACHINE

The conceptual design of the compacting machine developed was as shown in plate 1. The conceptual design was based on the usage and purpose of the blocks, the composition of the blocks and mode of transportation.

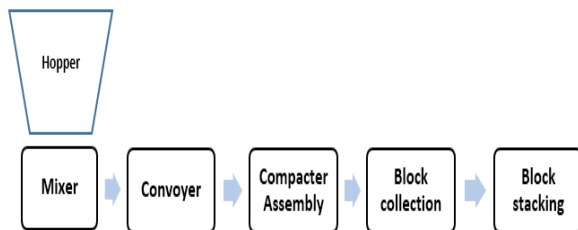

Plate 1: Conceptual design of the machine developed (Author)

2.1 Design Concepts

The following concept was developed

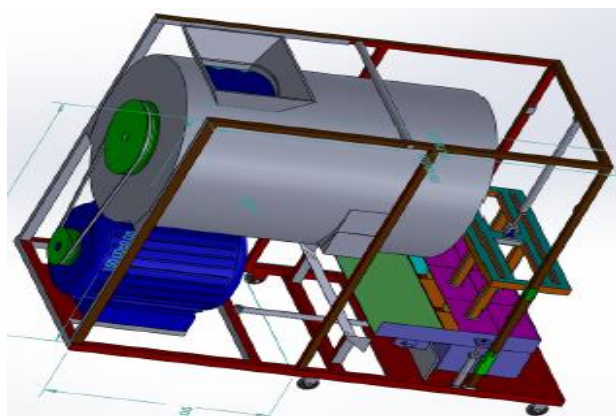

Plate 2: Design Concepts (Author)

2.2 Design calculations

The design calculations were as follows.

The material properties

The material used was mild steel with the following properties

Ultimate tensile strength	400Mpa
Yield strength σ_y tension	250 Mpa

2.4 The mould chamber`

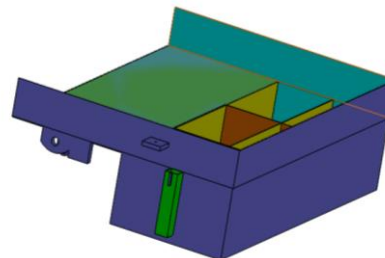

Plate 41: Mould developed

The mould chamber as in plate 3-4 was determined based on the size of the cocopeat block to be produced and the amount of the cocopeat mixture needed to produce the block, a constant volume approach was used. This was preferred as it produces blocks of the same dimensions for ease of stacking and transportation. The mould chamber was 600 mm by 300 mm by 80 mm

The factors that were considered include

- The cocopeat block dimensions (L x W x H) .(1)
 - Factor of safety = 4
 - The mould chamber to produce 4 blocks in a cycle
 - Mould chamber dimensions
 - Block Cross -Sectional area
 - Design compaction pressure
 - Design pressure

2.5 Mould Plate Thickness



The mould plate thickness was calculated using the relation, (Equating the maximum bending moment with the bending resistance of the plate material)

$$Wl^2/8 = f \times Z, \dots\dots\dots(2)$$

Where

W = load

l = length

t = thickness of plate

F = allowable bending stress = 0.66σ_y

Z = section modulus

$$Z = \frac{bt^2}{6}, \dots\dots\dots(3)$$

From the calculations thickness of the mould chamber walls was 10.8 mm

2.6 Deflection of the mould

The maximum deflection is given by $y_{max} = \frac{5wl^4}{384EI}$ (4)

Where :

W = distributed load(N/m)

L = Length of applied load (m)

I = area moment of inertia (m⁴)

E = Young's Modulus of elasticity (Pa or N/m²)

y_{max} = Maximum deflection

Deflection , $y_{max} = \frac{5wl^4}{384EI}$

This was considered minimal and therefore, the blocks had straight edges. The partitions in the mold chamber were joined by arc welding.

2.7 The piston rods

Since the load carrying capacity of the rods depend on the condition on the restraint at the two end of the rod, as shown in figure 3-2, which is given by a dimensionless quantity called end fixity coefficient(n) whose values are given in plate 3-6,

S. No.	End conditions	End fixity coefficient (C)
1.	Both ends hinged	1
2.	Both ends fixed	4
3.	One end fixed and other hinged	2
4.	One end fixed and other end free	0.25

Plate 5: Values of end fixity coefficient (C) for various end conditions

Using the Euler's equation, force per rod $F_{cr} = \frac{C\pi^2 EI}{L^2}$,

Where(5)

E= modulus of elasticity or young's modulus for the material

A= area of cross section

L= length of the beam

C =constant representing the end conditions of the piston or end fixity

I = moment of area

F_{cr} = force per rod (4 number)

Considering a circular rod, $I = \frac{\pi r^4}{4}$, $F_{cr} = \frac{\pi^2 E(\pi r^4)}{4L^2}$,
 $r^4 \geq \frac{4L^2 F_{cr}}{\pi^2 E}$ (6)

The diameter of the piston rods is 100 mm

2.8 Mixing cylinder design

The mixing cylinder is where a rotating shaft joined to mixing screw carries out the mixing process.

Determination of mixing cylinder volume

The mixing cylinder was designed to accommodate the volume of mix needed to produce at least 20 blocks per run. The length of the mixing chamber = 1.0 m, therefore, the diameter of the mixing chamber was given by

$V = \pi r^2 l$ (7)

The dimensions of the mixing chamber were 1 m length and 0.66 m diameter.

2.9 Bolt sizes

Since the machine was required to have ease of movement form one station to another, the major parts were fastened using bolts and nuts.

The bolt diameter was given by

$P = \frac{1}{4} * \pi d_c^2 * \sigma_c$ (8)

Where P- load

d= nominal diameter

d_c= core diameter

σ_c= allowable tensile stress

Mixing force of the mixer

The mixing force was calculated as below

$F = M_p \times g$ (9)

F= force

M = mass of cocopeat

g=gravitational acceleration

Loose density of cocopeat is 20 kg/ m³

Mass = density x volume(10)

Hopper

The hopper outlet must be large enough to prevent cohesive arches or stable ratholes from developing. The outlet size therefore depends on the cohesive strength and the bulk density of the cocopeat dust. The hopper was made of mild steel to standard at an inclined angle of 60° with respect to the mixing chamber when fixed horizontal.

2.10 Shaft

For the mixer, a shaft was used to support the rotating mixing blades. The shaft was subjected to axial or transverse loads as well as torsional loads acting singly or in combination. The shaft carries the blades and is powered by an electric motor though bearings and pulley system. The forces acting on the blades are transmitted to the shaft. These forces include the reaction due to weight of the blades, green compression strength of the mixer cocopeat and centrifugal effect of both the shaft and the blades.

2.11 Mixing speed

The shaft is attached to a pulley on the pulley system

Using pulley ratio and given that the motor speed N₁ is 1450 rpm, the shaft speed, N₂ in rpm was determined from the expression:

$$\frac{N_1}{N_2} = \frac{D_2}{D_1} \dots\dots\dots (11)$$

Angular velocity of the shaft = $\omega_s = \frac{2\pi N_2}{60} = 26.18$
rad.....(12)

Torque on the shaft

Torque of the shaft $T_s = r_b \times F_s$ (13)

$T_s =$ torque of the shaft

$r_b =$ radius of the blades = (0.33 m)

$F_s =$ force acting on the shaft

Power required for mixing the cocopeat

$$P_s(W) = T_s (N.m) \times \omega_s \dots\dots\dots (14)$$

The minimum diameter of the shaft

$$d_s = \sqrt[3]{\frac{16T_s}{\pi S_s}} \dots\dots\dots (15)$$

The efficiency of the mixer

The efficiency of the mixer was calculated using the equation

$$\epsilon = \frac{\text{output power/ powers required}}{\text{input power/ power supplied}} \times 100 \dots\dots\dots (16)$$

Where, The power required was calculated as 732.18W,

The power supplied was the rating of the electric motor provided is 0.75Kw, and

The efficiency was evaluated as 97%

Determined parameters

Parameter	Determined parameter
Yield stress	62.5 Mpa
Mold thickness	10.8 mm
Mold deflection	0.000104 mm
Piston rods diameter	100 mm
Length of mixing chamber	1 m
Diameter of mixing chamber	0.66 m
Bolt size (diameter)	7 mm
Shaft diameter	50 mm
Mixer efficiency	97%

III. MACHINE FABRICATION , AUTOMATION AND TESTING

3.1 Machine fabrication

The fabrication of the compaction machine was done through production of the various components and assembly. The fabrication of the various parts was carried out in the mechanical engineering workshop at JKUAT and Multimedia University. Standard parts were purchased from local dealers. The fabrication was modular, and at each stage on completion of a module, the module was tested for functionality before final assembly. The entire machine was assembled and tested to make sure that it functions as intended.



Plate 6: Fabricated machine

Frame

In machine fabrication, the frame was made of U- channels.

The material used is mild steel. The machine frame was made in a way that it can be assembled and dis- assembled for ease of moving it from one location to another. The cylinder frame was made of mild steel sheets.

The mold

The mold box assembly consists of two sides the longitudinal side and the lateral side. These sides form the longer side has a landing or conveyor for ease of filling the mold. It was made of mild steel.

Compaction plate.

The compaction plate was made of mild steel. It is placed below the mold.

The compacting chamber

The compaction chamber was made of mild steel. Considering end fixity points where both ends are fixed, the piston dimensions were round bars.

Mixing cylinder

The mixing cylinder designed to accommodate the volume of mix needed to produce blocks per cycle using a plate of required thickness. The mixing cylinder used bolts and nuts so that the mixing shaft can be dis-mantled from the cylinder when needed. The mixing cylinder included a shaft and an electric motor.

3.2 Hydraulic system circuit

The hydraulic system used consisted of three hydraulic cylinders, hose pipes, hydraulic pump, hydraulic valves and hydraulic reservoir tank. It also included sliding guides to align the moving parts. The hydraulic circuits transmit and control the power from mechanical input to mechanical output by means of liquids. Power transmitted hydrostatically. High pressures make static forces dominate over dynamic forces and energy is transmitted through static pressure at low flow velocities. The hydraulic pump pushes hydraulic fluid through the system to create fluid power. This fluid passes though the valves and flows to the cylinder where hydraulic energy converts into mechanical energy. Valves help to direct flow of the liquid and receive pressure as needed. The hydraulic system circuit is as shown in fig 1 below using FluidSim

Hydraulic system circuit

Hydraulic system circuit

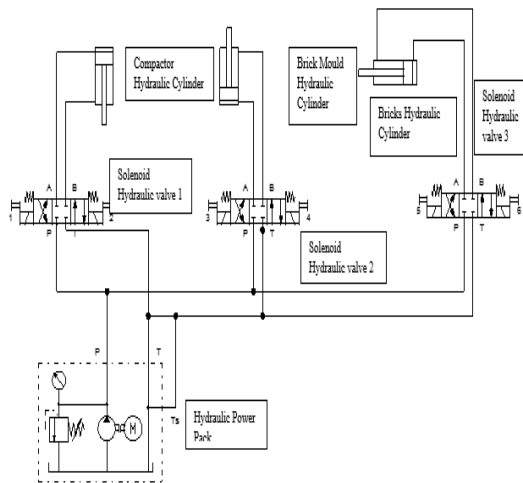

Figure 1: Hydraulic system circuit drawn using FluidSim (Hydraulics)

3.3 Machine control programme

The machine control programme was done using ladder logic as below.

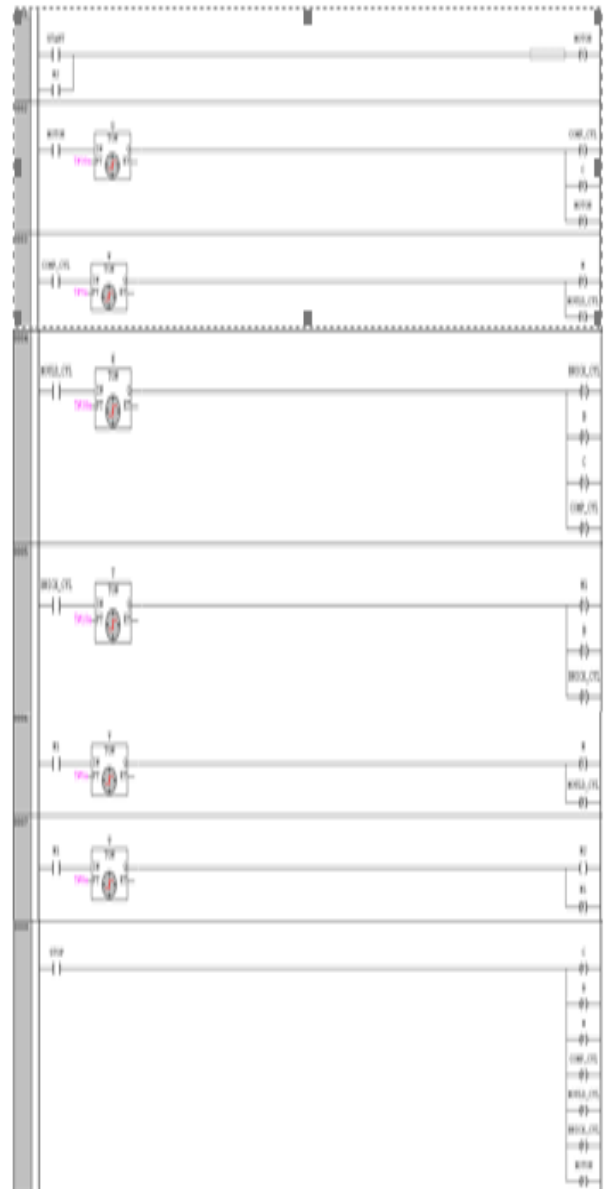

Plate 2: Machine control programme using ladder logic

3.4 PLC Control Circuit

The programmable control logic (PLC) is an industrial control system that continuously monitors the state of the input devices and does decisions based on a custom program to control the state of the output devices. It has the advantage of changing and replicating the operation or process while collecting and communicating vital information. There are four basic steps in the operation of PLCs, input scan, program scan, output scan, and housekeeping. Input scan detects the state of all the input devices that are connected to the PLC. The program scan executes the user created program logic. Output scan energizes or de-energizes all output devices that are connected to the PLC. Housekeeping step includes communications with programming terminals and internal diagnostics.

The control circuit used to control the operation of machine is as in plate 3.

Plate 3: Control circuit

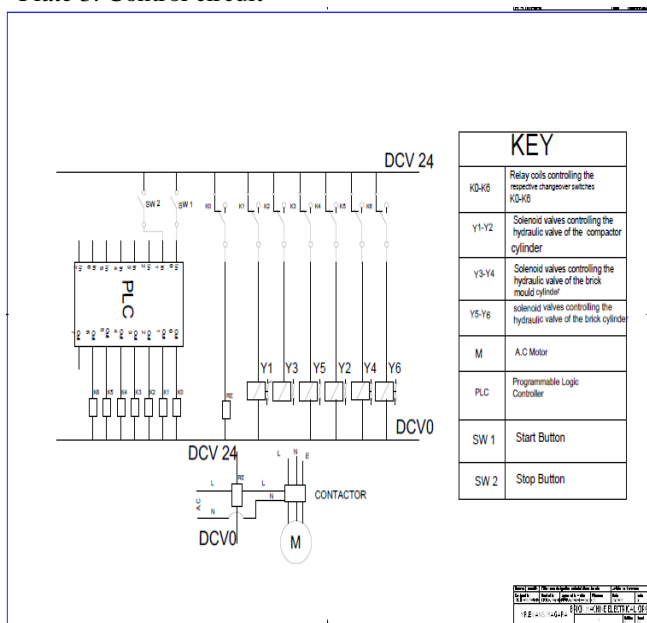

3.5 Machine Testing

Testing was critical as the machine was already assembled. Each component was first tested separately before the machine was tested as a whole. The hydraulic system was tested manually by means of directional- control valves to sure it works according to the design. This was done by trying to move the pistons up and down using buttons on hydraulic control system. The pressure control and the relief valves were tested to be sure that they are working well and that their performance is as required. The pressure indicator was monitored to ensure that the piston motion stops at the required pressure.

The next phase was to test the machine to ensure that it is working correctly as per the design. The test showed that the control system worked well. This indicated that the machine works as designed.

IV. CONCLUSION

The cocopeat compaction machine was designed, fabricated and tested. This machine is the main purpose of this project. This machine has many benefits. Compacting cocopeat is the most important benefit of the machine. Compacting cocopeat reduces its volume to make it easier to transport to agricultural farms which are usually located far from the cocopeat production areas. This increases savings in transportation costs, which will include in savings in fuel cost, labour cost, cost of whole truck of un compacted cocopeat, and maintenance costs for transportation trucks. These costs savings are an indication that the cocopeat compacting machine has reached its goal. It also helps in keeping the environment clean as it prevents overfilling of coconut shells in the farms, which are breeding zones for snakes and mosquitoes. Preventing or eliminating these heaps of coconut shells makes our country look attractive and thus improving the overall image of our nation. It works without human interference,

which will allow people to use it with ease. It is safe to use and portable.

V. RECOMMENDATIONS

The recommendations that could be done in order to reach a better solution to compacting cocopeat are either expensive or more advanced for a single product manufacture. Installing a solar panel unit, which will operate the machine using solar energy, which is a renewable energy source. This will reduce the machine running cost and make the machine more portable and for use in areas where there is no grid power.

Acknowledgements

I acknowledge the technical staff of Multimedia University for the technical assistance offered in the development of these paper. The management of Multimedia University for providing necessary equipment and materials and laboratories for all works done and the research chair , JKUAT, for their valuable guidance.

VI. REFERENCES

- 1 A study on the Physical and Hydraulic Characteristics of Coco Peat Perlite Mixture as a Growing Media in Containerised Plant Production 2017 *Sains Malaysia* 975-980
- 2 Agriculture and Food Authority. (2019, November 15th). Retrieved from <https://agricultureauthority.go.ke/>
- 3 Coconut Husk Mini-Chipper Machine. 2016 *International Journal of Engineering Research and General Science* 412091-2730
- 4 Design and development of Waste compactor for plastic bottles , metals cans and papers 2018 *university of Engineering college, Debrezeit, Ethiopia*.
- 5 Design and Fabrication of Coir Pith Prequetting Machine 2009 *World Applied Sciences Journal* 74552-558
- 6 Design and fabrication of Briquetting Machine for Solid Waste. 2018 *International Journal of Latest Engineering Research* 3561-66
- 7 Design and Fabrication of Coco Pith Block Making Machine 2017 *International Journal of Engineering and Advanced technology (IJEAT)* 64
- 8 Design construction and performance evaluation of a cocopeat block making machine 2019 *International Journal of Science and Technology*. 52202-212
- 9 Design Construction and testing of a Briquetting machine 2014 *Kwame Nkuruma University of Science and Technology - College of Engineering* 1-75



- 10 Design, Construction, and performance evaluation of a cocopeat block making machine2019*International Journal of Science and Technology*52202-212
- 11 Developemt of Briquette from Coir Dust and Rice Blend: An Alternative Energy Source2014*International Journal of Renewable Energy Development (IJRED)*32119-123
- 12 Development of a Coconut Dehusking for rural small scale farm holders*International Journal of Innovative Technology and Creative Engineering*231-7
- 13 Development of a Light Weight Briquetting Machine for Small and Medium Scale Enterprises FUPRE2018*Journal of Science and Industrial Research*212579-184
- 14 Kenya Bureau of Statistics 2019Economic Survey
- 15 Kenya National Bureau of Statistics2018*Economic Survey 2018* Nairobi
- 16 Performance Evaluation of Manually Operated Tamarind Briquetting Machine2013*International Journal of Food , Agriculture and Veterinaty Sciences* 3349-54
- 17 Production and quality testing of fuel briquettes made from pongamia and and tamarind shell2018*Indian Academy of Sciences*1-7
- 18 Research Factors Influence on Quality of Wood Briquettes2007*Journal Acta montanista ,Slovaca*123223-230
- 19 The Mutipurpose Utilization of Coconut By Products in Agriculture : Prospects and Concerns.2017*International Journal of Current Microbiology and Applied Sciences* 661408-1415
- 20 The Effect Of Improvement On Work Facility Of Coco Bristle Process To Occupational Health And Safety.2018*Indonesian Journal Of Community Engagement*

IJEAST

INTERNATIONAL JOURNAL
OF ENGINEERING APPLIED SCIENCE
AND TECHNOLOGY

ABOUT IJEAST

International Journal of Engineering Applied Science and Technology (IJEAST) is a peer-reviewed, open access journal that publishes high-quality research papers in the field of Engineering, Applied Science and Technology.

IJEAST aims to provide a platform for researchers, academicians, and professionals to share their innovative ideas, research findings, and practical experiences with the global scientific community.

FOCUS AREAS

- Engineering
- Applied Science
- Technology
- Innovation & Development
- Interdisciplinary Studies



PEER REVIEWED

All submissions are rigorously peer reviewed to ensure quality.



OPEN ACCESS

Free and unrestricted access to research for all.



GLOBAL REACH

Connecting researchers and professionals worldwide.



TIMELY PUBLICATION

We ensure a swift and efficient publication process.



For more information, visit our website

www.ijeast.com



INTERNATIONAL JOURNAL
OF ENGINEERING APPLIED SCIENCE
AND TECHNOLOGY

✉ editor@ijeast.com

🌐 www.ijeast.com

📍 India



2455-2143