



IJEAST

INTERNATIONAL JOURNAL
OF ENGINEERING APPLIED SCIENCE
AND TECHNOLOGY



VOLUME : 2 ISSUE : 2 Print / Issue Publication Date: 27-Jan-2017



ISSN : 2455-2143



Indexed In



WWW.IJEAST.COM

editor@ijeast.com



SENSOR BASED SMART IRRIGATION AND FIELD SECURITY CONTROL SYSTEM USING GSM TECHNOLOGY

Prof. Chetana Patil

Department of Electronics & Communication
Shaikh College of Engineering & Technology
Belagavi, Karnataka, India

Prof. Preeti Raikar

Department of Electronics & Communication
Shaikh College of Engineering & Technology
Belagavi, Karnataka, India

Abstract— The comfort of being able to take control of devices from one particular location has become imperative as it saves a lot of time and effort. The proposed system is an extended approach to automating irrigation control system. The objective of this work is to develop a control system that allows the farmer to remotely control and monitor multiple sensors using a GSM based basic cellular phone. This system will be a powerful and flexible tool that will offer service any time, and from anywhere. The proposed approach for designing this system is to implement a microcontroller-based control module that receives its instructions and command from a cellular phone over the GSM network. The microcontroller then will carry out the issued commands and then communicate the status of a given sensor or device back to the cellular phone.

Keywords—AT commands, field security, GSM module, soil moisture sensor

I. INTRODUCTION

The new age of technology has redefined communication. Most people nowadays have access to mobile phones and thus the world indeed has become a global village. The proposed design implements a GSM technology based control system that effectively allows control from a remote area to the desired location. The application of our suggested system is immense in the ever changing technological world. It allows a greater degree of freedom for our farmers in monitoring and controlling the basic activities at the field. The comfort of being able to take control of devices from one particular location has become imperative as it saves a lot of time and effort the agricultural activities in smart, safe and efficient manner. The system we have proposed is an extended approach to automating a control system.

There are several Problems faced by farmers while operating irrigation pumps which include physical effort and inconvenience of travelling to fields often at odd hours only to switch ON/OFF the motor due to erratic power supply. They often face the risk of wild animals, snakes, hazardous terrain and electric shocks while traveling to the fields in the dark and on rainy days. Existing aids like auto-starters are unreliable and incapable of communicating the operating state of the

motor to the farmer, especially when a farmer has more than one motor pump set; he has to run around to make sure that all the motor pumps are working when the power is available. Frequent damage of irrigation motors and starters are common due to voltage fluctuations, faults in three phase connectivity and running the motor in absence of water. Farmers have to spend a lot of money, time and energy to get them repaired; at times such a delay has a severe impact on crop yield. Motors, starters and cables need to be deployed in open fields and hence are easy targets for thieves. At times, motor pumps are left running for longer than what is necessary because of the effort involved in switching OFF the motor. This leads to wastage of both electricity and water.

II. PROPOSED METHODOLOGY

A. Implementation of the system—

This system is based on a combination of sensors and GSM module that are controlled using a Microcontroller. The moisture sensor is placed at the field which is continuously monitoring the moisture level of the field. This information is analog which is further fed to an ADC to convert it into its equivalent digital form. Now this digital information is sent to the microcontroller which will compare the received information with a pre stored value. The microcontroller is programmed to set a particular value for the moisture level of the soil. Based on the moisture level the microcontroller commands the water pump to go ON/OFF. Also the microcontroller will send a message to a predefined mobile, mentioning the status of the moisture level as well as of the motor. Even if the motor is ON the moisture sensor is still sensing the moisture level of the soil, and once the moisture level of the soil reaches to its maximum, the microcontroller commands the water pump to go OFF. The status of the field is sent to the predefined cell phone through the GSM modem.

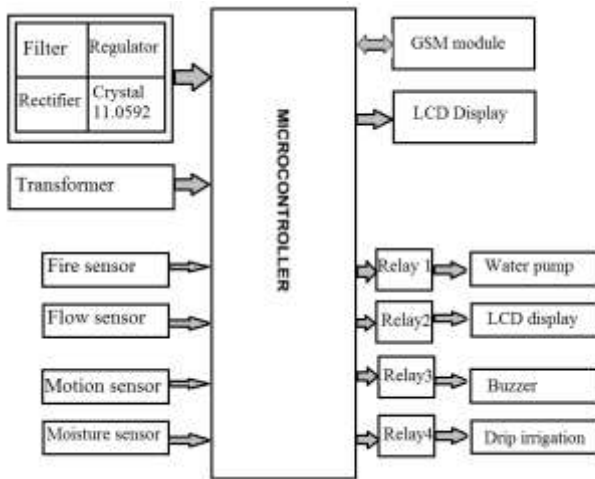

Fig. 1. Block diagram

Several sensors such as soil moisture sensor, fire sensor, flow and motion sensors are used to monitor the field condition. Each sensor is dedicated to a particular automating activity, providing efficient monitoring and controlling mechanism at the field. AT-attention commands of GSM are used to communicate with the components and its user.

III. SENSORS USED

A. Soil Moisture Sensor SA SM01

The Soil Moisture Sensor accurately measures soil moisture for many applications. The sensor requires no maintenance and has Analogue Output variations from 0.60volts - 12volts. The moisture gauge averages moisture through a column of soil equal to its length when placed vertically, or will measure moisture at a specific soil depth when placed horizontally.

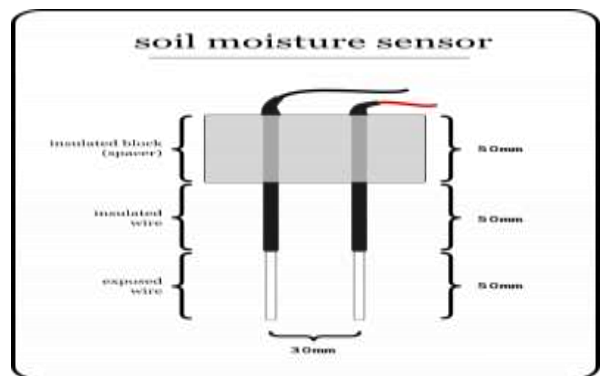

Fig.3. Moisture sensor

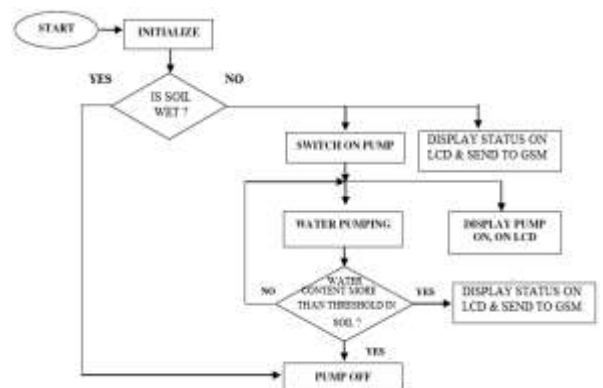

Fig.4. Software flow for motion sensor

B. Interfacing of water pump with Microcontroller

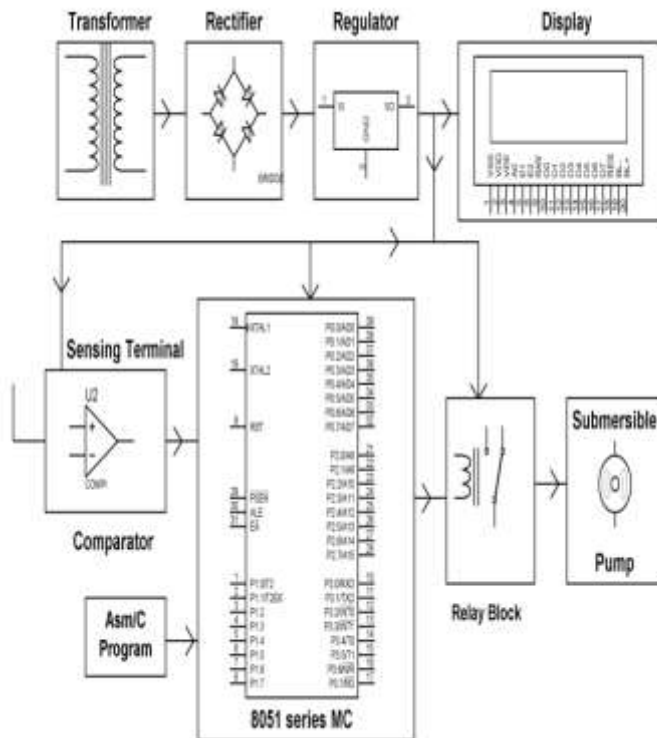

Fig. 2. Block diagram of interfacing with Microcontroller

The proposed system employs two microcontrollers, out of one which is dedicated at the water pump and other to the sensors. The interfacing of the water pump with the microcontroller is as shown in the figure 2.

B. Water Flow Sensor

A Water flow sensor is a device which is used to measure the flow rate and water consumption for residential and commercial water filters. The main purposes are: water heater thermostat, water purifier, boiler, water dispenser, coffee

machine, smart card equipment, wall-hung boilers burning appliances such as water flow sensing the product interfaces diameter 7mm.

C. Fire Detection Sensor

The Flame Detection Sensor is a very sensitive sensor that gives the output in form of both analogue and digital. Has a very high and wide angel of detection of a flame. This sensor is efficient enough to detect a wave or fire of wavelength in 760 to 1100nm range. This sensor is well suited for fire alarms or any robotic projects that includes fire.

D. Motion Sensor

The PIR (Passive Infra-Red) Sensor is a pyro electric device that detects motion by measuring changes in the infrared levels emitted by surrounding objects. This motion can be detected by checking for a high signal on a single I/O pin. It operates on 5v DC Supply. It gives Logic high output (5V) whenever any motion is detected. Pyro-electric devices, such as the PIR sensor, have elements made of a crystalline material that generates an electric charge when exposed to infrared radiation. The changes in the amount of infrared striking the element change the voltages generated, which are measured by an on-board amplifier. The device contains a special filter called a Fresnel lens, which focuses the infrared signals onto the element. As the ambient infrared signals change rapidly, the on-board amplifier trips the output to indicate motion.

IV. GSM MODULE AND AT COMMANDS



Fig. 5. GSM Sim300 Module

The The Global System for Mobile Communication (GSM) network is a cellular telecommunication network with a versatile architecture complying with the ETSI GSM 900/GSM 1800 standard. iemen's implementation is the digital cellular mobile communication D900/1800/1900 that uses the very latest technology to meet every requirement of the standard.

AT commands

AT commands are used to control MODEMs. AT is the abbreviation for Attention. These commands come from Hayes commands that were used by the Hayes smart modems. The Hayes commands started with AT to indicate the attention from the MODEM. The dial up and wireless MODEMs (devices that involve machine to machine communication) need AT commands to interact with a computer. These include the Hayes command set as a subset, along with other extended AT commands. AT commands with a GSM/GPRS MODEM or mobile phone can be used to access information and services such as information and configuration pertaining to mobile device or MODEM and SIM card, SMS services, MMS services, fax services, data and voice link over mobile network.

V. CONCLUSION

The proposed design provides an automated system which would monitor and manage the agriculture field in the absence of human being. It also aids in preventing losses caused due to animals, thieves, birds and fire etc. This system fulfills all the requirements of farmers and provides solution for the basic problems which tend to occur in agricultural fields. The future implications of the project are very great considering the amount of time and resources it saves. The project we have undertaken can be used as a reference or as a base for realizing a scheme to be implemented in other projects of greater level such as weather forecasting, temperature updates, device synchronization, etc

VI. REFERENCE

- [1] F.H. Tani, S. Barrington. "Zinc and copper uptake by plants under two transpiration rates. Part I. Wheat (*Triticum aestivum* L.)," *Environmental Pollution*, 138. pp. 538-547, 2005.
- [2] Haley, M.D. Dukes. 2007. Evaluation of sensor based residential irrigation water applications. ASABE 2007.
- [3] Rohit Somvanshi, Akshay Suryawanshi, Rohit Toraskar, "Smart Irrigation System Using Mobile Phone", *International Research Journal of Engineering and Technology (IRJET)* e-ISSN: 2395 -0056 Volume: 03 Issue: 04 , Apr-2016.
- [4] Prakash persada, Nadine Sargsterb, Edward Cumberbatchc, aneil Ramkhalawand and Aatma maharaj, "Investigating the Feasibility of solar powered irrigation for food crop production. ISSN 1000 7924.
- [5] Joaquin Gutierrez, Juan Francisco Villa-Medina, Alejandra Nieto-Garibay "Automated Irrigation System Using a Wireless Sensor Network and GPRS Module" *IEEE Transactions on Instrumentation and Measurement* , Volume: 63, Issue: 1, Jan. 2014 .

IJEAST

INTERNATIONAL JOURNAL
OF ENGINEERING APPLIED SCIENCE
AND TECHNOLOGY

ABOUT IJEAST

International Journal of Engineering Applied Science and Technology (IJEAST) is a peer-reviewed, open access journal that publishes high-quality research papers in the field of Engineering, Applied Science and Technology.

IJEAST aims to provide a platform for researchers, academicians, and professionals to share their innovative ideas, research findings, and practical experiences with the global scientific community.

FOCUS AREAS

- Engineering
- Applied Science
- Technology
- Innovation & Development
- Interdisciplinary Studies



PEER REVIEWED

All submissions are rigorously peer reviewed to ensure quality.



OPEN ACCESS

Free and unrestricted access to research for all.



GLOBAL REACH

Connecting researchers and professionals worldwide.



TIMELY PUBLICATION

We ensure a swift and efficient publication process.



For more information, visit our website

www.ijeast.com



INTERNATIONAL JOURNAL
OF ENGINEERING APPLIED SCIENCE
AND TECHNOLOGY

✉ editor@ijeast.com

🌐 www.ijeast.com

📍 India



2455-2143