



IJEAST

INTERNATIONAL JOURNAL
OF ENGINEERING APPLIED SCIENCE
AND TECHNOLOGY



VOLUME : 1 ISSUE : 5 Print / Issue Publication Date: 09-Oct-2016



ISSN : 2455-2143



Indexed In



WWW.IJEAST.COM

editor@ijeast.com



PERFORMANCE OF P&O MPPT AND FUZZY LOGIC MPPT IN A PHOTOVOLTAIC GRID INTEGRATED SYSTEM

Murali Mohan.T

Department of Electrical and Electronics Engg.
UCEK, JNTU Kakinada, Kakinada, AP, India

Vakula .V.S

Department of Electrical and Electronics Engg.
UCEV, JNTUK, Vizayanagaram, AP, India

Abstract—This paper presents the grid integration of photovoltaic systems where two maximum power point tracking techniques are employed separately and studied their performance under different operating conditions such as shaded and unshaded cases with photovoltaic system perspective and with various load conditions from the load perspective. The inverter of cascaded h-bridge type has been used and simulated for a three level configuration. Though the inverter output is not a pure sinusoidal, a filter circuit has been included next to the inverter to produce pure sinusoidal signal. The entire system has been simulated and studied the performance under different situations where the results show that under partial shadings of PV array the fuzzy MPPT performed better.

Keywords— PV system, P&O MPPT, Fuzzy logic MPPT, cascaded h-bridge inverter

I. INTRODUCTION

A wide spread utilization of solar energy generated from solar light motivated the engineers and researchers to do more investigation into the photovoltaic (PV) systems. The integration of power became a good practice at different voltage levels in transmission and distribution networks. Integrating is a practice starting from the domestic consumer to the individual power producer. However the main disruptions to the PV integration during and after, from technical point of view are maintenance of voltage and frequency and phase angles in coincidence with the grid parameters. According to the literature it has been observed that the internal impedance of the PV system normally does not match with the load impedance which results into extraction of power from the PV array will be less [1]-[4]. This problem can be minimized by using the maximum power point tracking techniques which works in such a way that the source impedance matching to the load impedance matching is done at the every sampling interval more appropriately. Then there is a chance to extract maximum power. In this paper two popularly used MPPT techniques such as perturb and observe (P&O) technique and fuzzy logic MPPT are modelled and

simulated in accordance to the practical situations and results are compared [5]-[8].

Importantly PV systems are tested for different shadings and load conditions as they are prevailing in the practical operation of the system. The shadings are formed mainly due to the movement of clouds over the panels, shadow formation due to the nearby buildings where they are mounted, due to the tall structures and very rarely failure of the modules in an array [9]-[10]. These disruptions reduce the solar irradiance on the panels which results into a reduction in the power production from pv system. The power output of the PV panels mainly depends on the solar irradiance, and temperature received by the panels. It is important to note that these partial shadings would also affect the power output. This shows the importance for partial shadings and the fuzzy logic based MPPT has shown better performance under normal conditions has chosen for testing under special partial shading conditions [11]-[15]. Multilevel inverters are used to synthesize the desired voltage at the output terminals by combining several DC voltage sources. Importantly multilevel inverter based voltage source inverters are classified into topologies: neutral point clamped (NPC), cascaded h-bridge, and flying capacitors. Among these three cascaded h-bridge has the higher output voltage and power levels and it has higher reliability due to its modular in nature [16]-[18].

Though there are different levels are possible in cascaded h-bridge inverter, three level cascaded h-bridge is used for the integration. An appropriate filter has been designed to produce a sinusoidal voltage at the inverter terminals. A three phase grid of same voltage magnitude, phase sequence and frequency was designed and simulated in the MATLAB/SIMULINK environment. Three phase load of static type has been designed and connected at the point of common coupling (PCC) which was simulated for different magnitudes and different power factors and the same has been tested for different irradiance conditions keeping the temperature constant across the modules as the temperature has less effect than the irradiance the effect of temperature has been neglected [19]-[27].

II. PHOTOVOLTAIC SYSTEM

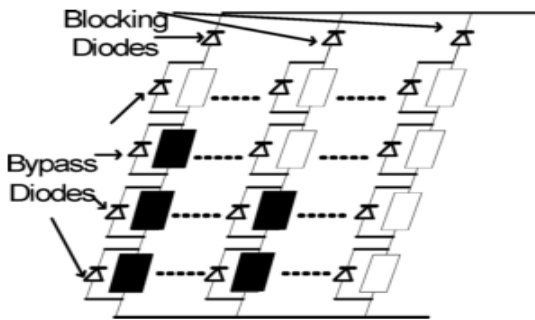

Fig.1. PV array with bypass and blocking diodes.
 The dark modules imply shading

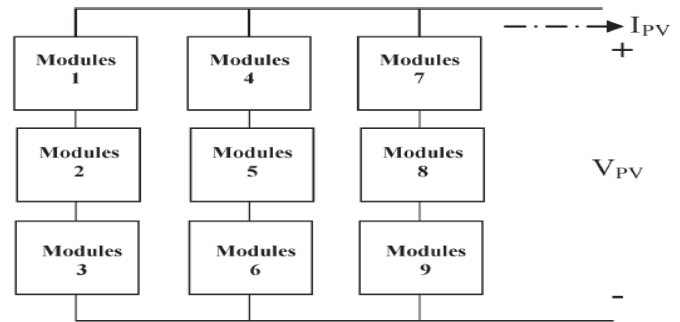

Fig.4. PV array system with nine module

The modules connection suitable for partial shadings is shown in figure 1 where the number of modules connected in series to form a string and number of such strings are connected together in parallel to enhance the current level. Each module is bypassed with a diode to provide an alternative path for current when the module is partially or fully shaded. Each string has a series connected diode to prevent the reverse flow of power into the string.

One important characteristic of an array is shown in figure 2 which shows I-V characteristic of an array having number of strings connected in parallel when some of the modules in two strings undergo two different partial shadings. This partial shading leaves the non-uniform current magnitudes in three strings as a result the array current is non uniform.

Figure 3 illustrates the characteristic drawn between power output of the array versus the array voltage. It is observed that there are multiple peaks present in the curve due to the partial shadings of the strings in an array. This leaves a technical challenge to the researchers to track the global maximum power operating point at any point of time. In figure 4 the pattern of PV modules arranged for conducting the simulation study has shown.

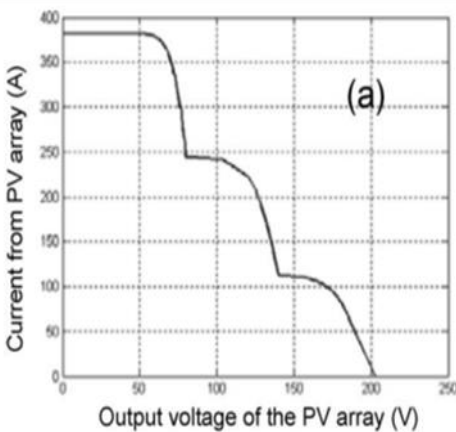

Fig.2. I-V curve of a typical PV array

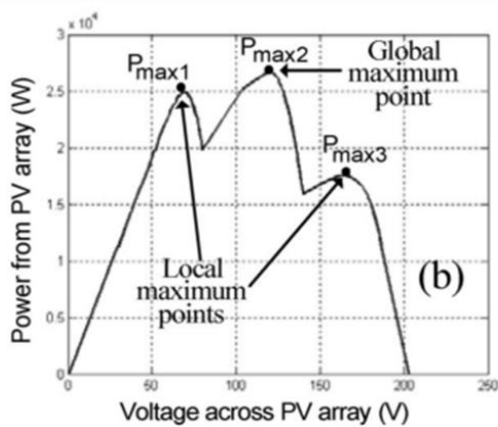

Fig.3. P-V curve of a typical PV array

III. PERTURB AND OBSERVE MPPT AND FUZZY LOGIC MPPT

A. Perturb and Observe MPPT

This is a simple and direct method where the voltage and current across the array are measured and used to find out the power at intervals k and $(k-1)$. When the difference of power $P(k)-P(k-1)$ is positive, the voltage differences $V(k)-V(k-1)$ is measured as positive then the V_{ref} will be increased or else when $V(k)-V(k-1)$ is negative then the V_{ref} will be reduced. Suppose if the difference of power is negative and difference of voltages is positive then the V_{ref} is reduced or else when the difference of voltage is negative V_{ref} is increased. In all the specified cases the operating point moves to the peak power point and the corresponding flow chart is shown in figure 5.

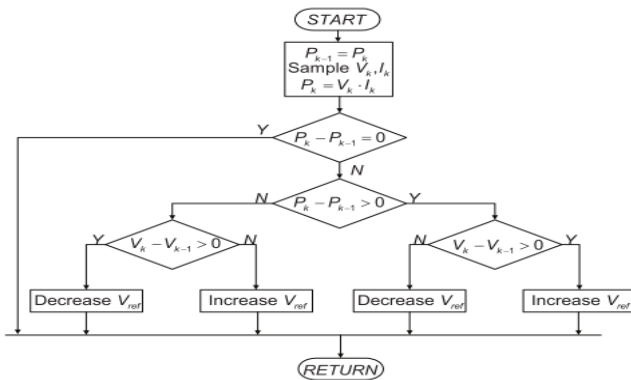

Fig.5. P&O Algorithm

B. Fuzzy logic MPPT

The inputs to the fuzzy logic controller are V_{pv} and I_{pv} are the PV output voltage and current, respectively, D is the duty cycle, P_m is the global maximum power point (PMM), and ΔP_m is a constant which represents the allowable difference between the global maximum point and the operating power point. In the proposed method a large perturbation is made to identify a global maximum power point over a wide range on the PV locus. Whenever the global maximum point exceeds during tracking the duty cycle must return to minimum value. Scanning and storing the PV power are accomplished during perturbation and observation. A fuzzy logic based MPPT is preferred with the proposed method; because the tracking speed is not constant. During initial or varying weather conditions, the initial tracking speed should be fast enough to make a wide range of scan and store the global maximum. However, the tracking speed should decrease once the global maximum point is reached to minimize any oscillation around the global maximum point. The proposed controller with a PV system is shown in figure 6.

The inputs to the fuzzy logic controller are

- (i) Change in power from k^{th} and $(k-1)^{th}$ time interval.

$$\Delta P = P(k) - P(k - 1)$$

- (ii) Change in current from k^{th} and $(k-1)^{th}$ time interval.

$$\Delta I = I(k) - I(k - 1)$$

- (iii) Change in power between the global maximum power and the power at k^{th} interval.

$$\Delta P_M = P_m(k) - P(k)$$

and the output of the fuzzy logic controller is

- (i) Change in boost converter duty cycle between present and previous time interval.

$$\Delta D = D(k) - D(k - 1)$$

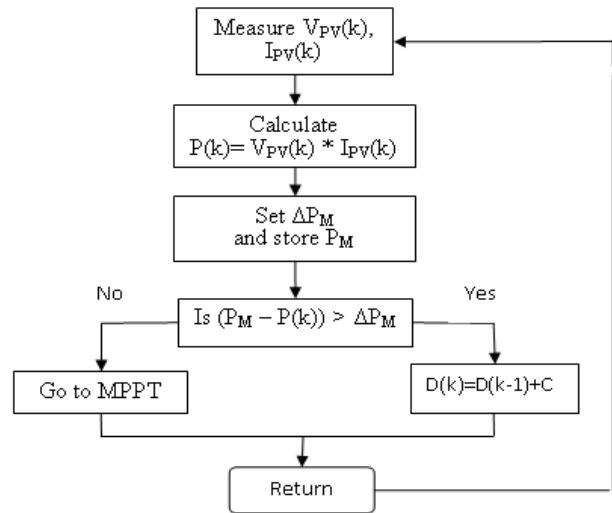

Fig.6. Flow chart of fuzzy logic based MPPT

Equations (1), (2), (3), and (4) are used for forming the fuzzy logic rule table which is used in fuzzy inference engine shown in table 1.

Table 1. Fuzzy logic rules

| $\Delta I \backslash \Delta P$ | NB | NS | PS | PB | ΔP_M |
|--------------------------------|----|----|----|----|--------------|
| NB | PM | PM | NM | NM | PS |
| NS | PS | PS | NS | NS | PS |
| PS | NS | NS | PS | PS | PS |
| PB | NM | NM | PM | PM | PS |
| NB | PB | PB | PB | PB | PB |
| NS | PB | PB | PB | PB | PB |
| PS | PB | PB | PB | PB | PB |
| PB | PB | PB | PB | PB | PB |

The variable inputs ΔP and ΔI are divided into four fuzzy subsets: positive big (PB), positive small (PS), negative big (NB), and negative small (NS). The variable input ΔP_M is divided into two fuzzy sub sets: PB and PS. The output variable ΔD is divided into six fuzzy subsets: PB, PM, PS, NB, NM, and NS. Therefore, the fuzzy algorithm requires 32 fuzzy control rules; these rules are based on the regulation of a hill climbing algorithm along with the reference power. To operate the fuzzy combination, Mamdani's method with max-min is used.

IV. CASCADED THREE LEVEL H-BRIDGE INVERTER

The H bridge inverter is a multi-level inverter that has been widely used in high power and medium voltage applications. By increasing the number of levels in a given topology, the output voltages in the case of VSI shall be increased.

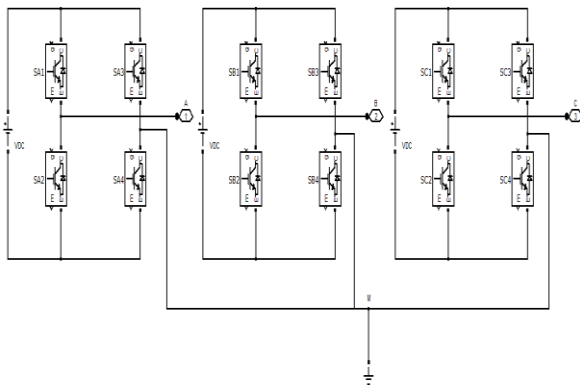

Fig.7. Three level h-bridge inverter

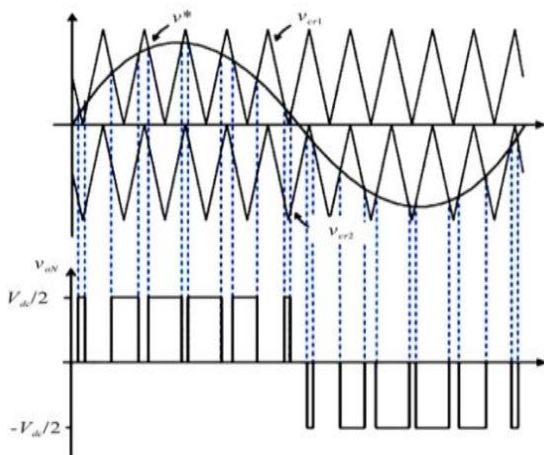

Fig.8. Phase disposition PWM technique

The three phase three level inverter topology consists of three H-bridge inverters shown in Fig. 7. Each DC link is fed by a short string of PV panels. By different combinations of the four switches in each H bridge, three output voltage levels can be generated, $-V_c$, 0, or V_c . PWM techniques are represented by fixed amplitude pulses. This is the most suitable method of controlling the output voltage. This method is labelled as Pulse-Width Modulation (PWM) Control. Though there are different PWM techniques the phase disposition PWM is more popular and is shown in fig.8.

V. GRID CONNECTED PV SYSTEM

Grid inverter needs a pure sinusoidal reference voltage to ensure that the sinusoidal output of the inverter is synchronized to the grid frequency. The control strategy applied for inverter consists of two control loops. Usually there is a fast inner control loop which controls grid current and an external voltage loop which control dc link voltage. The current control loop is responsible for power quality issues like low THD and good power factor, whereas voltage control loop balances the power flow in the system. Synchronous reference frame control also called d-q control uses a reference frame transformation abc to dq which transforms the grid current and voltages into d-q frame. After that, the stationary frame quantities are transferred into synchronous rotating frames using cosine and sinus functions from the phase-locked loop (PLL).

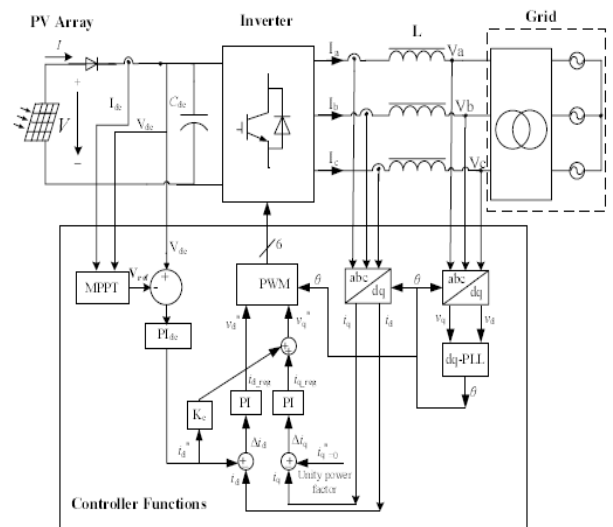

Fig.9. Configuration of grid connected PV system

The sines and cosine functions would help to maintain the synchronization with supply voltage and current. The transformed voltage detects phase and frequency of grid, whereas transformed current controls the grid current. Thus the control variables becomes dc values, hence filtering and controlling becomes easier. The simulation is carried out of three phase three level H bridge inverter for grid connected photovoltaic system at a temperature of 25°C and an irradiance of 1000W/m^2 under different partial shading conditions of PV panel are performed. Simulation circuit of three phase multi-level inverter for grid connected PV system is implemented for fig.9. PV sub system has been considered and its electrical characteristics are in Table I and the MPPT algorithm includes Perturb and Observe method is applied to this system. The parameters for the grid and inverter are shown in table 2.



VI. RESULTS AND DISCUSSION

Case-1: The irradiance have been given as 1000 W/m^2 in the first row, 200 W/m^2 in the second row and 1000 W/m^2 in the third row. However, the temperature has been assumed as constant across the modules. This indicates that there is partial shading in the second row modules made the irradiation less than the standard value.

Table-1 Photovoltaic array specifications

| Parameter | Value |
|-------------------------------------|--|
| Maximum power (P_{max}) | 1372.14 W |
| Voltage at Pmax (V_{mp}) | 108 V |
| Current at Pmax (I_{mp}) | 12.705 A |
| Open-circuit voltage (V_{oc}) | 130.2 V |
| Short-circuit current (I_{sc}) | 13.2 A |
| Temperature coefficient of I_{sc} | $(0.0032 \pm 0.015) \% / ^\circ\text{C}$ |
| Temperature coefficient of V_{oc} | $-(80 \pm 10) \text{ mV} / ^\circ\text{C}$ |

Table-2 Grid & filter Specifications

| Parameter | Value |
|------------------------------------|--------------------|
| Grid line voltage (V_{L-L}) | 415 V |
| Grid phase voltage (V_{ph}) | 240 V |
| DC source voltage (V_{dc}) | 100V |
| DC current (I_{dc}) | 10A |
| Output power fed to grid (P_n) | 1000W |
| Grid frequency (f) | 50 Hz |
| Switching frequency(f_s) | 1 KHz |
| Filter inductor | 70 mH |
| Filter Capacitor | 60 μF |
| Parameters PI | $K_p=10, K_i=0.02$ |

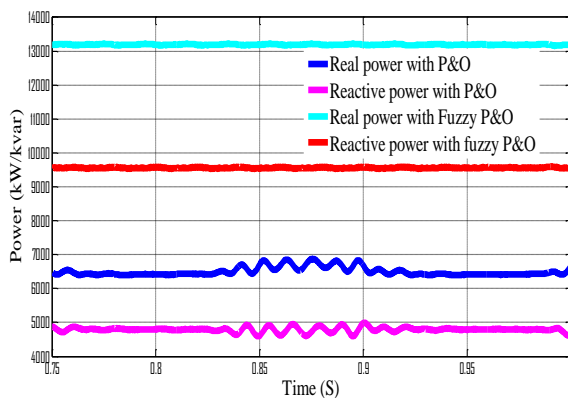

Fig.10. Power drawn from grid side in case-1

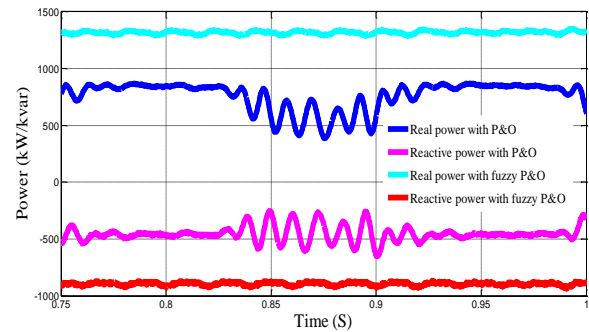

Fig.11. Power drawn from inverter terminals in case-1

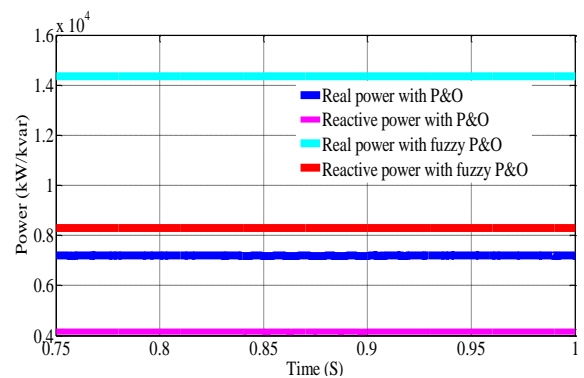

Fig.12. Power flow into the load terminals in case-1

Figures 11 through 13 illustrate power drawn from grid, inverter and load terminals respectively in case-1. It is easily estimated that the power flow into the load terminals is the sum of the powers comes out of the inverter and the load.

Case-2: The irradiances of 1000 W/m^2 , 0 W/m^2 , 0 W/m^2 are given in the modules of row 1, row 2, and row 3 respectively. However temperature has been set constant at 25°C across the array.

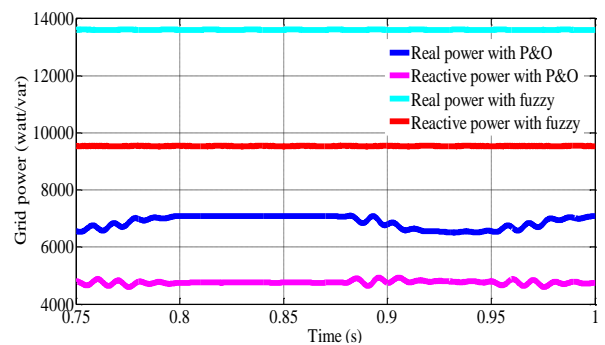

Fig.13. Grid power from case-2

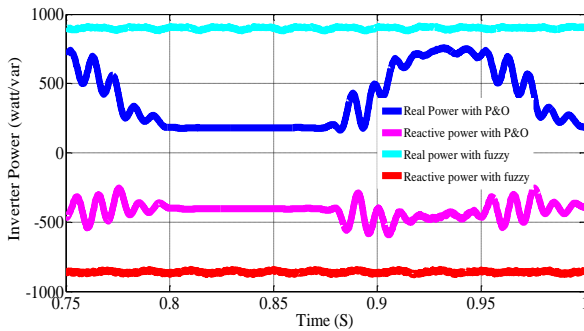

Fig.14. Inverter power from case-2

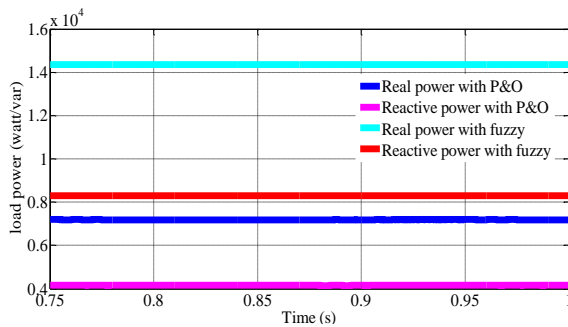

Fig.15. Power at load terminals in case-2

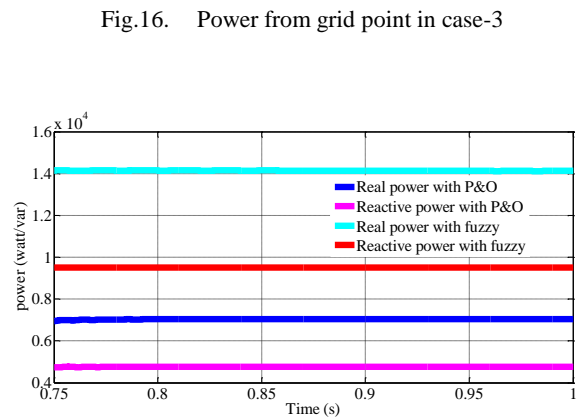

Fig.16. Power from grid point in case-3

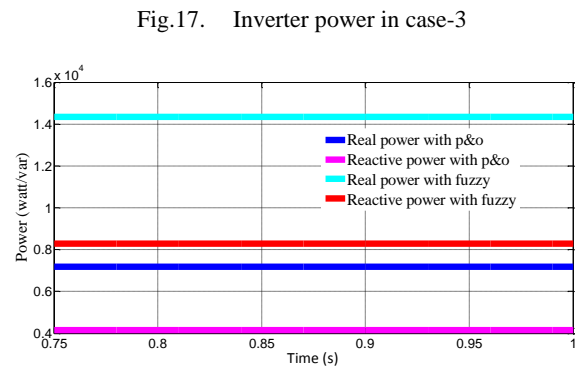
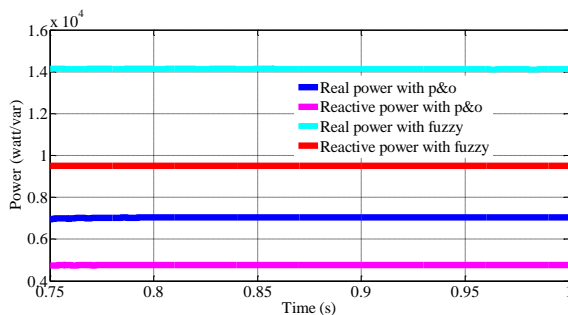

Fig.17. Inverter power in case-3

Fig.18. Power at load terminals in case-3

Figures 14 through 16 show the waveforms of the power flows from grid, inverter and load terminals respectively. By choosing that pattern of irradiance two strings are go out of service due to the assumption of full shading. This brings the power derived from the inverter would be less and that in turn increases the burden on the grid to meet the power at the load point.

Case-3: A Pulse type of irradiance of the form 400 W/m^2 from 0 sec to 0.3 Sec, 1000 W/m^2 from 0.3 Sec to 0.6 Sec, and 200 W/m^2 from 0.6 Sec to 1.0 Sec has been considered across all the modules to reflect the changes in the irradiance over a short time interval of 1 Sec.



VII. CONCLUSION

PV system model suitable for all shaded and non-shaded situations is simulated and observed the characteristics. The P&O MPPT and fuzzy MPPT were designed and simulated to study their performance under various irradiance conditions. As inverter is mandatory to integrate into the grid, cascaded h-bridge inverter has been simulated and integrated the PV system through the inverter. Various shadings on the PV array are chosen and performance of both the MPPTs has been studied for a common load connected. The results show that the power flow into the load is the sum of the powers supplied by the inverter and the grid. Under partial or full shaded PV panels case the output power from the inverter reduces as a result it increases the burden on the grid. Apart from the two MPPTs the fuzzy logic based MPPT showed a better performance in extracting the power from the PV array all situations particularly under partial shadings.

VIII. REFERENCES

- [1] D. Hohm and M. Ropp, Comparative study of maximum power point tracking algorithms using an experimental, programmable, maximum power point tracking test, Photovoltaic Specialists Conference Record of the Twenty-Eighth IEEE, 2000, pp. 1699–1702.



- [2] Femia, N., Petrone, G., Spagnuolo, G., Vitelli, M., Optimization of perturb and Observe MPPT method, IEEE trans. Power Electron., 2005, 20, (4), pp.963-973.
- [3] E. Roman, R. Alonso, P. Ibanez, S. Elorduiza patarietxe, and D. Goitia, *Intelligent PV* module for grid-connected PV systems, IEEE Transactions on Industrial Electronics, June 2006, vol. 53, no. 4, pp. 1066–1073.
- [4] G.A.R.F. Brambilla A., Gambarara M., New approach to photovoltaic arrays maximum *power point tracking*, Proceedings of Power Electronics Specialists Conference, 2004.
- [5] ESRAM, T., Chapman, P.L., Comparison of photovoltaic array maximum power point techniques, IEEE Trans. Energy Convers., 2007, 22, (2), pp.439-449.
- [6] N. Femia, D. Granozio, G. Petrone, G. Spagnuolo, and M. Vitelli, Predictive & adaptive MPPT Perturb and Observe method, IEEE Transactions on Aerospace and Electronic Systems, 2007, vol. 43, no. 3, pp. 934–950.
- [7] T. ESRAM and P. Chapman, Comparison of photovoltaic array maximum power point *tracking techniques*, IEEE Transaction on Energy Conversion, 2007, vol. 22, no. 2, pp. 439–449.
- [8] Kjaer, S., Evaluation of the hill climbing and incremental conductance maximum power point trackers for photovoltaic power systems, IEEE Trans. Energy Convers., 2012, 27, (4), pp.922-929.
- [9] Hiren Patel and Vivek Agarwal, MATLAB-Based Modeling to Study the Effects of Partial Shading on PV Array Characteristics, IEEE Transactions on Energy Conversion, March 2008, Vol. 23, No. 1.
- [10] Kun Ding, XinGao Bian, HaiHao Liu, and TaoPeng, A MATLAB Simulink Based PV Module Model and its Application Under Conditions of Nonuniform Irradiance, IEEE Transactions on Energy Conversion, December 2012, Vol. 27, No. 4.
- [11] A. Chaouachi, R.M. Kamel, and K. Nagasaka, MPPT Operation for PV Grid-connected System using RBFNN and Fuzzy Classification, World Academy of Science, Engineering and Technology, 2010, Vol:4, PP.05-25.
- [12] B. Alajmi, K. Ahmed, S. Finney, and B. Williams, Fuzzy logic controlled approach of a modified hill climbing method for maximum power point in micro grid stand-alone photovoltaic system, IEEE Trans. Power Electron., Apr. 2011, vol. 26, no. 4, pp. 1022–1030.
- [13] Eftichios Koutroulis, and Frede Blaabjerg, A New Technique for Tracking the Global Maximum Power Point of PV Arrays Operating Under Partial Shading Conditions, IEEE journal of photovoltaics, April 2012, Vol. 2, No. 2.
- [14] Young-Hyok Ji, Doo-Yong Jung, Jun-Gu Kim, Jae-Hyung Kim, Tae-Won Lee, and Chung-Yuen Won, A Real Maximum Power Point Tracking Method for Mismatching Compensation in PV Array Under Partially Shaded Conditions, IEEE transactions on power electronics, April 2011, Vol. 26, No. 4.
- [15] Bader N. Alajmi, Khaled H. Ahmed, Member, IEEE, Stephen J. Finney, and Barry W. Williams, A Maximum Power Point Tracking Technique for Partially Shaded Photovoltaic Systems in Microgrids, IEEE Transactions on Industrial Electronics, April 2013, vol. 60, No. 4.
- [16] J. S. Lai and F. Z. Peng, "Multilevel converters – A new breed of power converters," IEEE Trans. Ind. Applicat., vol. 32, pp. 1098–1107, May/June 1996.
- [17] J. Rodriguez, J.-S. Lai, and F. Z. Peng, "Multilevel inverters: a survey of topologies, controls, and applications," IEEE Trans. Ind. Electron., vol. 49, pp. 724–738, 2002.
- [18] L. M. Tolbert, F. Z. Peng, and T. G. Habetler, "Multilevel converters for large electric drives," IEEE Trans. Ind. Applicat., vol. 35, pp. 36–44, 1999.
- [19] H. Stemmler, Power electronics in electric traction applications. IEEE conference of Industrial Electronics, Control and Instrumentation, IECON'93, 2:7 07 – 713, 1993.
- [20] H. Fujita, S. Tominaga, and H. Akagi. Analysis and design of an advanced static VAR compensator using quad-series voltage-source inverters. IEEE Industry Apps Meeting, 3:2565–2572, 1995.
- [21] Y. Yoshioka, S. Konishi, N. Eguchi, M. Yamamoto, K. Endo, K. Maruyama, and K. Hino. Self-commutated static flicker compensator for arc furnaces. In IEEE Applied Power Electronics Conference, volume 2, pages 891–897, 1996.
- [22] L. Gyugyi, "Power electronics in electric utilities: static var compensators.," Proc. IEEE, vol. 76, pp. 3, 1987.
- [23] Peter W. Hammond. A new approach to enhance power quality for medium voltage AC drives. IEEE Trans. Industry Applications, 33(1):202–208, January 1997.
- [24] M. F. Escalante, J. C. Vannier, and A. Arzande "Flying Capacitor Multilevel Inverters and DTC Motor Drive Applications," IEEE Transactions on Industry Electronics, vol. 49, no. 4, Aug. 2002, pp. 809-815.
- [25] L. M. Tolbert, F. Z. Peng, "Multilevel Converters as a Utility Interface for Renewable Energy Systems," in Proceedings of 2000 IEEE Power Engineering Society Summer Meeting, pp. 1271-1274.
- [26] L. M. Tolbert, F. Z. Peng, T. G. Habetler, "A Multilevel Converter-Based Universal Power Conditioner," IEEE Transactions on Industry Applications, vol. 36, no. 2, Mar./Apr. 2000 pp.596-603.
- [27] L. M. Tolbert, F. Z. Peng, T. G. Habetler, "Multilevel Inverters for Electric Vehicle Applications," IEEE Workshop on Power Electronics in Transportation, Oct 22-23, 1998, Dearborn, Michigan, pp. 1424-1431.

IJEAST

INTERNATIONAL JOURNAL
OF ENGINEERING APPLIED SCIENCE
AND TECHNOLOGY

ABOUT IJEAST

International Journal of Engineering Applied Science and Technology (IJEAST) is a peer-reviewed, open access journal that publishes high-quality research papers in the field of Engineering, Applied Science and Technology.

IJEAST aims to provide a platform for researchers, academicians, and professionals to share their innovative ideas, research findings, and practical experiences with the global scientific community.

FOCUS AREAS

- Engineering
- Applied Science
- Technology
- Innovation & Development
- Interdisciplinary Studies



PEER REVIEWED

All submissions are rigorously peer reviewed to ensure quality.



OPEN ACCESS

Free and unrestricted access to research for all.



GLOBAL REACH

Connecting researchers and professionals worldwide.



TIMELY PUBLICATION

We ensure a swift and efficient publication process.



For more information, visit our website
www.ijeast.com



INTERNATIONAL JOURNAL
OF ENGINEERING APPLIED SCIENCE
AND TECHNOLOGY

✉ editor@ijeast.com

🌐 www.ijeast.com

📍 India



2455-2143