



IMPROVING TRANSIENT STABILITY OF WIND FARM USING FACTS DEVICES FOCUSED ON STATCOM

Kumar Pushpak, Anuradha, Balram Kumar, Agnivesh Ravi
Department of Electrical Engineering,
Roorkee, India

Abstract— The paper provides an optimized STATCOM control for wind electric generator. The transient behaviour of fixed-speed wind farms can be improved by injecting large amounts of reactive power during the fault recovery.

When integrated to the power system, large wind farms pose stability and control issues. A thorough study is needed to identify the potential problems and to develop measures to mitigate them. Although integration of high levels of wind power into an existing transmission system does not require a major redesign, it necessitates additional control and compensating equipment to enable recovery from severe system disturbances. This article will provide the use of a Static Synchronous Compensator (STATCOM) along with wind farms for the purpose of stabilizing the grid voltage after grid-side disturbances such as a three phase short circuit fault, temporary trip of a wind turbine and sudden load changes.

Application of FACTS controller called Static Synchronous Compensator STATCOM to improve the transient stability in the presence of faults and the integration of new renewable source, like wind energy, these make the electrical grid operate in a new condition. The essential feature of the STATCOM is that it has the ability to absorb or inject fastly the reactive power with power grid entirely by means of electronic processing of the voltage and current waveforms in a voltage source converter (VSC). In the present paper transient stability improvement using STATCOM under faults is proposed.

Keywords- STATCOM, wind power, reactive power, transient stability, FACT devices, VSC

I. INTRODUCTION

To have the sustainable growth and social progress, and with the increase in demand of power and decrease of fossil fuels, mankind has been forced to search alternative sources to meet the energy need by utilizing the renewable energy resources like wind, biomass, hydro, co-generation, etc. for the generation of electricity. In sustainable energy system, energy conservation and the use of renewable source are the key paradigm. The need to integrate the renewable energy like wind energy into power system is to make it possible to minimize the environmental impact on conventional plant. Nowadays

wind as a significant proportion of non-pollutant energy generation, is widely used. Wind power in spite of being stochastic in nature has proved itself as a viable solution to this problem. As the wind turbine technology is developing at a good pace, more and more wind power plants are being integrated with the conventional form of generation

II. WIND FARM

A wind farm or wind park is a group of wind turbines in the same location used to produce electricity. A large wind farm may consist of several hundred individual wind turbines and cover an extended area of hundreds of square miles, but the land between the turbines may be used for agricultural or other purposes. A wind farm can also be located offshore. Many of the largest operational onshore wind farms are located in Germany, China and the United States. For example, the largest wind farm in the world, Gansu Wind Farm in China has a capacity of over 6,000 MW of power in 2012 with a goal of 20,000 MW by 2020. The Alta Wind Energy Center in California, United States is the largest onshore wind farm outside of China, with a capacity of 1,020 MW. As of April 2013, the 630 MW London Array in the UK is the largest offshore wind farm in the world, followed by the 504 MW Greater Gabbard wind farm in the UK. The world's first wind farm was 0.6 MW, consisting of 20 wind turbines rated at 30 kilowatts each, installed on the shoulder of Crotched Mountain in southern New Hampshire in December 1980.

III. PROBLEMS RELATED TO GENERATION OF POWER WITH THE HELP OF WIND FARM:-

With the increase in the ratio of wind generation to conventional generation, several problems related with integration of wind energy into existing power system presents a technical challenges and that requires consideration of voltage regulation, stability, power quality problems of wind farms have emerged. In addition, power transmission and distribution systems face **increasing demands for more power, better quality and higher reliability at lower cost**, as well as low environmental effect. Under these conditions, transmission networks are called upon to **operate at high transmission levels**, and thus power engineers have had to confront some **major operating problems** such as

transient stability, damping of oscillations and voltage regulation etc. The individual units can be of large capacity up to 2 MW, feeding into distribution network, particularly with customers connected in close proximity. Today, more than 28000 wind generating turbine plants are successfully operating all over the world. In the fixed speed wind turbine operation, all the fluctuation in the wind speed are transmitted as fluctuations in the mechanical torque, electrical power on the grid and leads to large voltage fluctuations. During the normal operation, wind turbine produces a continuous variable output power. These power variations are mainly caused by the effect of turbulence, wind shear, and tower-shadow and of control system in the power system. There has to be a protection for such situations. Thus, the network needs to manage for such fluctuations. The power quality issues can be viewed with respect to the wind generation, transmission and distribution network, such as voltage sag, swells, flickers, harmonics etc.

performance, a higher rating SVC is required when compared to that of a STATCOM.

For an SVC, the maximum transient capacitive current is determined by the size of the capacitor and the magnitude of the ac system voltage.

In the case of a STATCOM, the maximum transient capacitive overcurrent capability is determined by the maximum turn-off capability of the power semiconductors employed.

IV. EXISTING TECHNIQUES FOR TRANSIENT STABILITY IMPROVEMENT

1. Using Doubly-Fed Induction Wind Generator (DFIWG) can improve transient stability
2. Super Capacitor Energy Storage System (SCESS) is proposed for stability analysis, but using wind turbine fixed-speed squirrel-cage generators, so its electrical and mechanical characteristics will slow the recovery of post-fault voltage, it connected to the weak the grid will lead voltage, rotor instability, interaction with the grid so that it bring impact on voltage transient stability.
3. Static Synchronous Compensator (STATCOM) control program is proposed also can control reactive power.
4. STATCOM/BESS (Balance Error Scoring System) is introduced, although it can control both active power and reactive power, but battery energy storage system has slow reaction and short lifetime.

V. COMPARISON OF SVC AND STATCOM

The Static VAR Compensator (SVC) and Static Synchronous Compensator (STATCOM) have a strong influence on voltage quality improvement and show medium performance with respect to overall system stability.

The STATCOM is the best option available for providing efficient voltage quality in the power system. The STATCOM can be operated over its full output current range even at very low voltage levels and the maximum VAR generation or absorption changes linearly with the utility or ac system voltage.

The maximum compensating current of the SVC decreases linearly with the ac system voltage and the maximum VAR output decreases with the square of the voltage. This implies that for the same dynamic

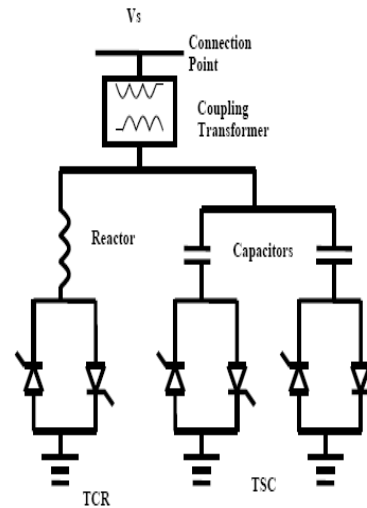

Figure 1: Schematic of SVC.

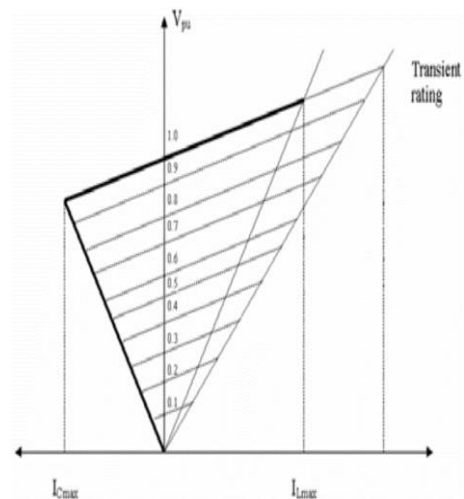

Figure 2: VI characteristics of SVC

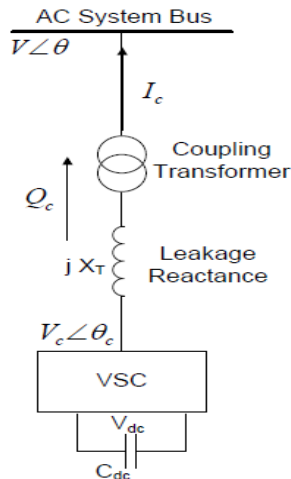

Figure 3: Schematic of the STATCOM

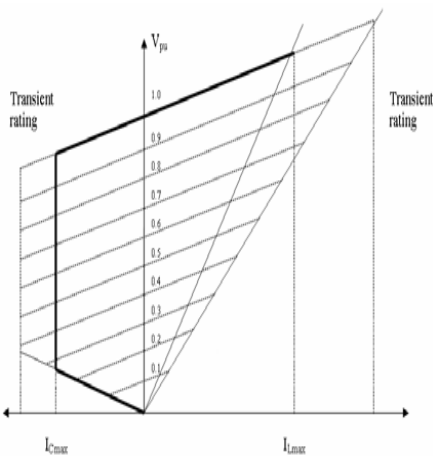

Figure 4: VI characteristics of the STATCOM

The STATCOM has better reactive power control than an SVC as seen in Figures A and B. Mechanically switched capacitors do not have a better performance at lower voltages and hence a higher rating device is needed for the same performance. Also, the reactive power support provided by the SVC is dependent on the ac system voltage and hence its capability is degraded at lower voltages.

VI. STATCOM PREFERENCE OVER OTHER TECHNIQUES

Capacitors are usually connected to fixed speed wind turbines to enhance the system voltage because they are a sink of reactive power. Mechanically switched fixed shunt capacitors can enhance the system's voltage stability limit, but is not very sensitive to voltage changes. Also, voltage regulated by the wind generators equipped with only

Fixed capacitors can become higher than the voltage limit of 1.05 pu. Hence, a fixed capacitor cannot serve as the only source of reactive power compensation.

One of the most important advantages of using STATCOM over a thyristor based SVC is that its compensating current is not dependent on the voltage level at the connection point which means that the compensating current is not lowered as the voltage drops.

The output of the wind power plants and the total load vary continuously throughout the day. Reactive power compensation is required to maintain normal voltage levels in the power system. Reactive power imbalances, which can seriously affect the power system, can be minimized by reactive power compensation devices such as the

STATCOM- The STATCOM can also contribute to the low voltage ride through requirement because it can operate at full capacity even at lower voltages.

A STATCOM's advantages include flexible voltage control for power quality improvement, fast response with better performance at lower voltages and applicability for use with high fluctuating loads then the SVC.

VII. MODEL OF WIND FARM WITH THE USE OF STATCOM USING MATLAB SIMULINK

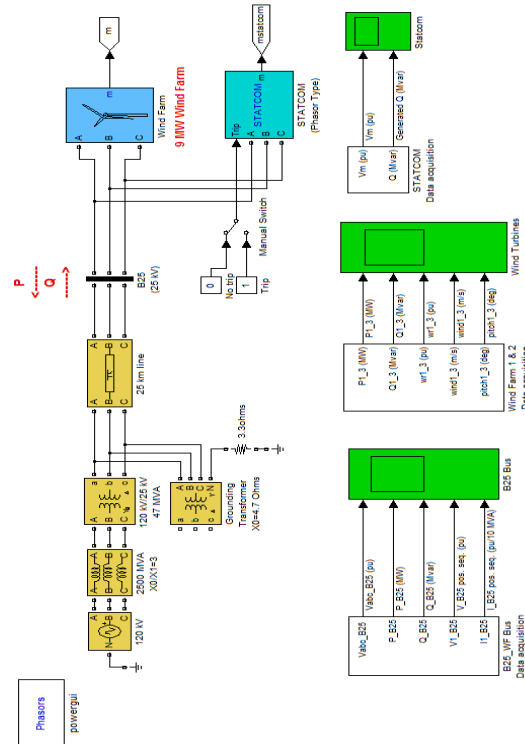

Fig.5 Model Of Wind Farm With The Use Of STATCOM Using Matlab Simulink

VIII. MODEL OF WIND FARM WITHOUT THE USE OF STATCOM USING MATLAB SIMULINK

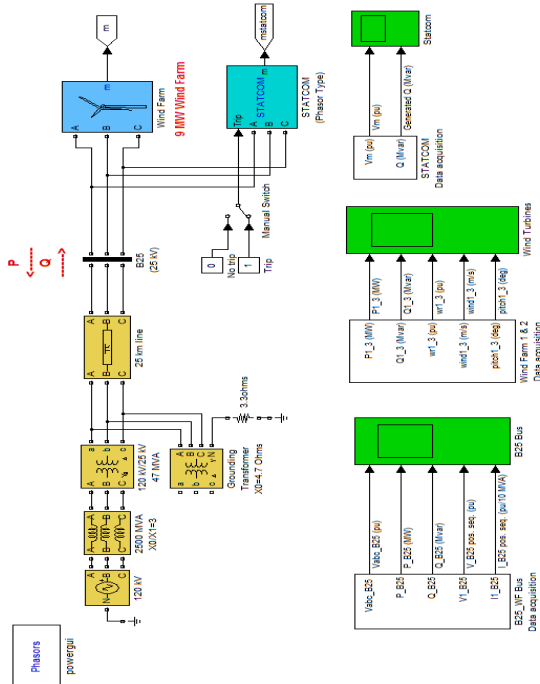
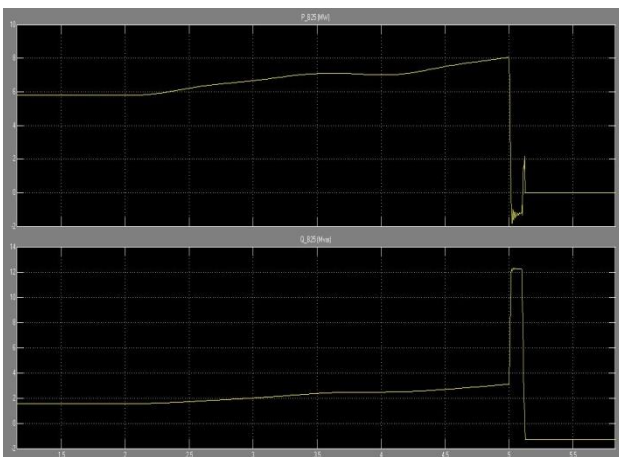
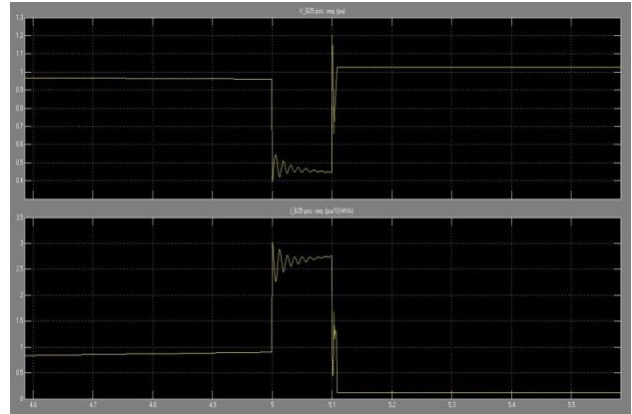

Fig.6. Model Of Wind Farm Without The Use Of STATCOM Using Matlab Simulink

IX. RESULTS OF THE MODEL SIMULATED.



Graph 1 Active And Reactive Power Waveform Of B25 Bus For 3 Phase Fault Without The Use Of STATCOM



Graph 2 Voltages and Current Waveform of B25 Bus For 3 Phase Fault without the Use of STATCOM



Graph 3.Active and Reactive Power Waveform Of Wind Farm For 3 Phase Fault Without The Use Of STATCOM

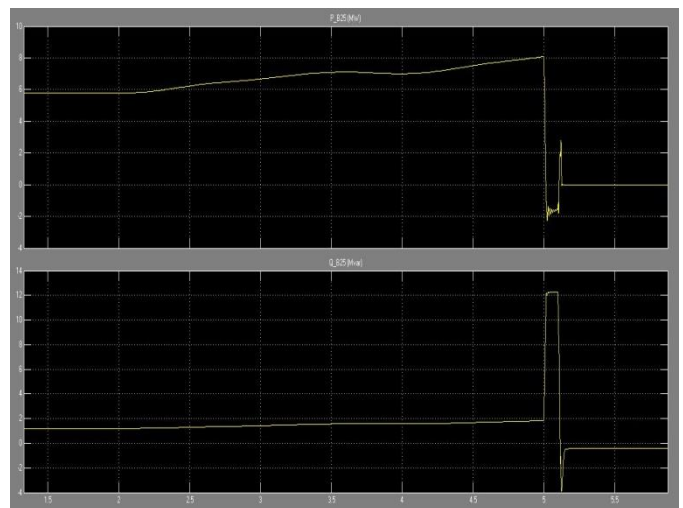

Graph 4 Active And Reactive Power Waveform Of B-25 Bus For 3 Phase Fault With The Use Of STATCOM

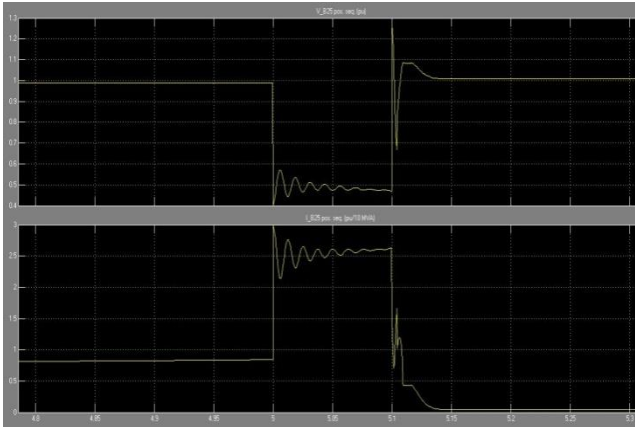

Graph 5 Voltage And Current Waveform Of B25 Bus For 3 Phase Fault With The Use Of STATCOM

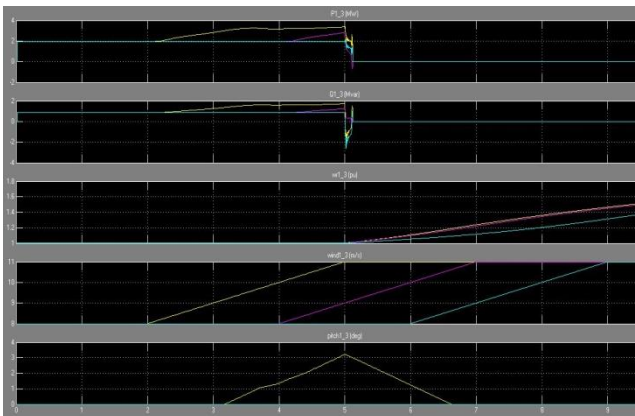

Graph 6 Active And Reactive Power Waveform Of Windfarm For 3 Phase Fault With The Use Of STATCOM

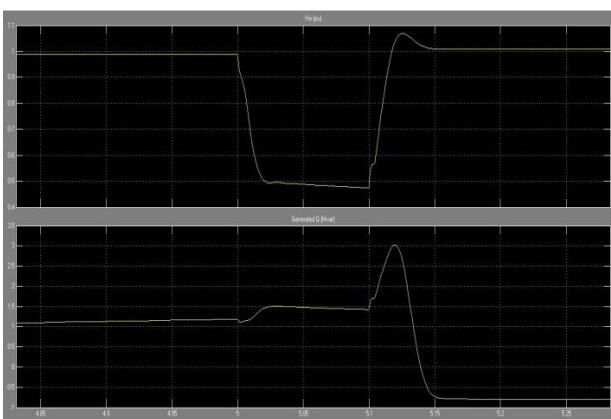

Graph 7 Amount Of Reactive Power Generated By STATCOM For 3 Phase Fault

X. CONCLUSION

FACTS devices are power electronics based reactive compensators that are connected in a power system and

are capable of improving the power system transient performance and the quality of supply.

This paper has discussed that the power system with wind farms performance can be improved using FACTS devices such as STATCOM. To validate the effect of the STATCOM controller of power system operation, the system is and will be further subjected to different disturbances such as faults and power operating conditions.

Further in the near future the use of STATCOM can be designed and simulated showing the stable power of wind farms which has not been described yet. The ultimate goal of the paper is to achieve and increase the stability of power in its disturbances occurring during the generation resulting in the stable system and the achieving highest efficient energy.

XI. REFERENCES

- [1] Tamer A. Kawady and Ahmed M.Nahas, "Modelling Issues of Grid Integrated Wind Farms for Power System Stability Studies," *Modelling and Control Aspects of Wind Power System*, pg no.- 156.
- [2] Z. Chen Senior Member,IEEE, "Issues of Connecting Wind Farms into Power Systems", *2005 IEEE/PES Transmission and Distribution Conference & Exhibition: Asia and Pacific Dalian, China*, pg no.- 2- 4.
- [3] P. Sravanthi & K. Radha Rani, "Transient Stability improvement of SCIG Based Wind farm With STATCOM", *International Journal of Electrical and Electronics Engineering Research (IJEER)*, 2014, vol. 4. Issue 2, April 2014 pg no.-47-52.
- [4] Prity Bisen and Amit Shrivastava, "Comparison between SVC and STATCOM FACTS devices for Power System Stability Enhancement", *International Journal on Emerging Technologies*, October 2013, pg no.- 1-2.
- [5] Aditya Jayam Prabhakar, "Application of STATCOM for Improved Dynamic Performance of Wind Farms in a Power Grid", *Missouri University of Science and Technology*, pg no.- 12-18, April 2008.
- [6] Valarmathi,R.and A.Chilambuchelvan, "Power Quality Analysis in 6 MW Wind Turbine Using Static Synchronous Compensator", *American Journal of Applied Sciences* 9 (1), 2012, pg no.- 111-116.