



COMPARISON ANALYSIS OF ULTRA, VISIBLE AND INFRA HIGH CAPACITY INTERSATELLITE OPTICAL WIRELESS COMMUNICATION SYSTEM USING DISTINCT MODULATION FORMATS

Vibhuti Sharma
Student, Dept. of ECE,
Ludhiana College of Engineering
& Technology Katani Kalan,
Ludhiana, Punjab, India

Gurinder Singh
Assistant Professor, Dept. of ECE,
Ludhiana College of Engineering
& Technology Katani Kalan,
Ludhiana, Punjab, India

Baljeet Kaur
Assistant Professor, Dept. of ECE,
Guru Nanak Dev Engineering
College, Ludhiana, Punjab, India

Abstract— In this paper, The inter-satellite link is intended for external modulation of Return to zero (RZ), Non return to zero (NRZ), duo binary return-to-zero (DRZ), carrier-suppressed return-to-zero (CSRZ), and modified duo binary return-to-zero (MDRZ) at 10 Gbps and 2500 Km distance. The setup of this system is accomplished by utilizing 16-channel ultra dense wavelength division multiplexing and simulated at bit rate of 10 Gbps in various electromagnetic bands i.e. visible wavelength, infrared wavelength and ultraviolet wavelength. The simulation outcome reveals that ultra violet wavelength (10-400 nm) range is best for transmission of signal through these diverse modulation formats. The ultra violet range has better result in case of CSRZ. CSRZ Quality factor (Q) is 7.94% more than infrared range and 2.45% more than visible range.

Keywords— IsOWC, RZ, NRZ, CSRZ, DRZ, MDRZ, Q Factor

I. INTRODUCTION

Intersatellite optical communication system is the communication between two satellites which are located at different orbits. In this system the data signals are transmitted from transmitter satellite to receiver satellite by air medium with light signal as the carrier signal [1]. The ultra dense WDM and the optical wireless communication (OWC) system combination brings about high speed and high bandwidth [2]. The OWC channel can work in a few electromagnetic band like infrared wavelength (700-10000 nm), ultraviolet wavelength (10-400 nm) and visible wavelength (400-700nm). In this paper, intersatellite OWC system with these wavelengths and diverse modulation formats is introduced.

Infrared: is an imperceptible brilliant vitality, electromagnetic radiation with longer wavelengths than those of visible light, and it ranges from 700nm (430 THz) to 1000000 nm (300 GHz).

Ultraviolet: The ultra violet is the part of electromagnetic radiation spectrum whose wavelength range is 10 nm (30 PHz) to 400 nm (750 THz). This wavelength range is less than visible light but more than X beams.

Visible: The visible range corresponds to a wavelength of 390-700 nm i.e. 430-770 THz. The human eye is not equipped for seeing radiation with wavelength outside the obvious range.

The paper contains depiction of modulation formats in segment 2, proposed system in segment 3 and results and discussion in segment 4 and after that conclusion in segment 5.

II. MODULATION FORMATS

Five types of modulation formats are used in this paper. They are RZ, NRZ, DRZ, CSRZ AND MDRZ.[4]

(1) Return to zero modulation format:

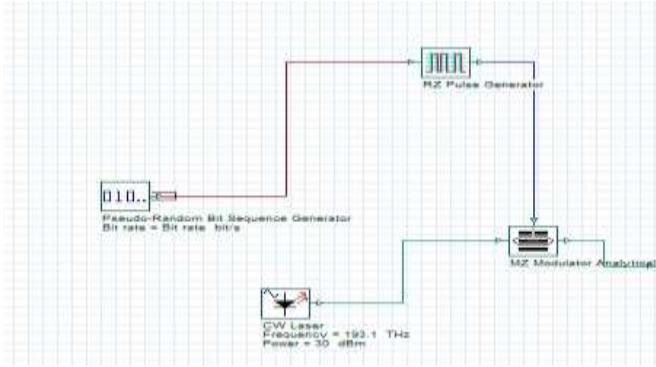

Fig .1.(a) RZ Modulation

Figure 1 (a) shows a system transmitting a RZ signal. In this format the pulse with bit 1 is lesser than the bit slot and its amplitude becomes zero before the ending of bit interval.

(2) Non Return to Zero modulation format:

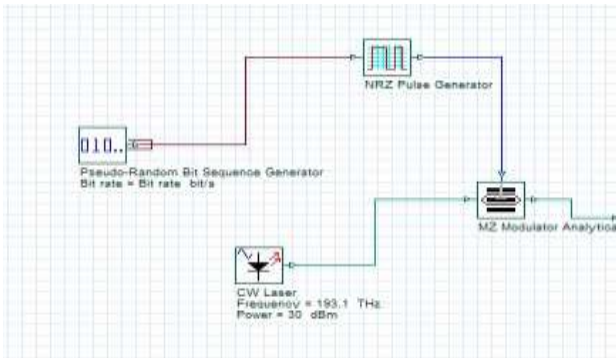

Fig .1.(b) NRZ Modulation

Figure 1 (b) shows a system transmitting a NRZ signal. In this format, the pulse is present for the entire time on the bit interval.

(3) Duobinary Modulation Format:

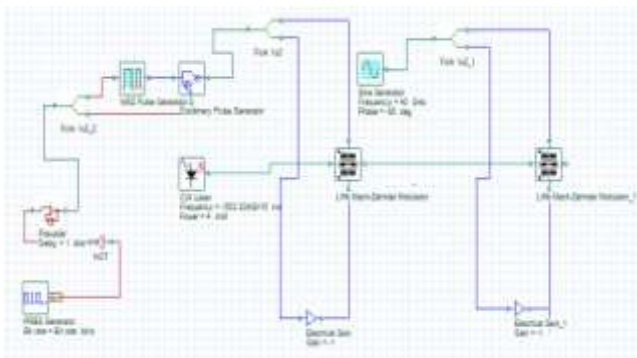

Fig .1.(c) DRZ Modulation

Figure 1 (c) shows a system transmitting a DRZ signal. First step is to create NRZ Duobinary signal with the help of precoder and Duobinary pulse generator. The generator is connected further with first MZM and the second MZM is connected with sine generator of frequency 40 GHz.

(4) Carrier suppressed Return to Zero Modulation Format:

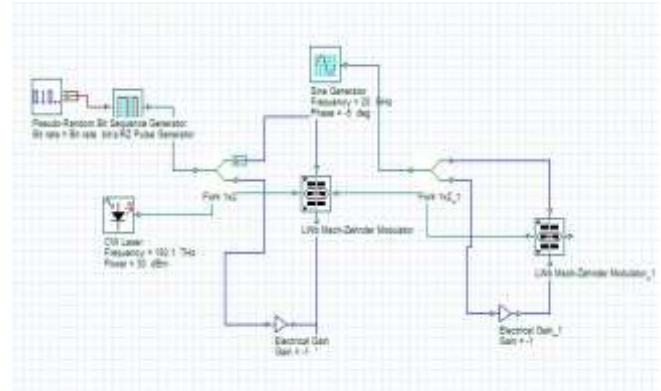

Fig .1.(d) CSRZ Modulation

Figure 1 (d) shows the system transmitting CSRZ signal. The CSRZ signal is generated by similar method of RZ format. The recurrence of the sinusoidal electrical signal connected in the second MZM has half of the bit rate. The second MZM was one-sided in an approach to give substituting optical stages between 0 to π for the neighboring time slots.

(5) Modified Duobinary return to zero Modulation Format:

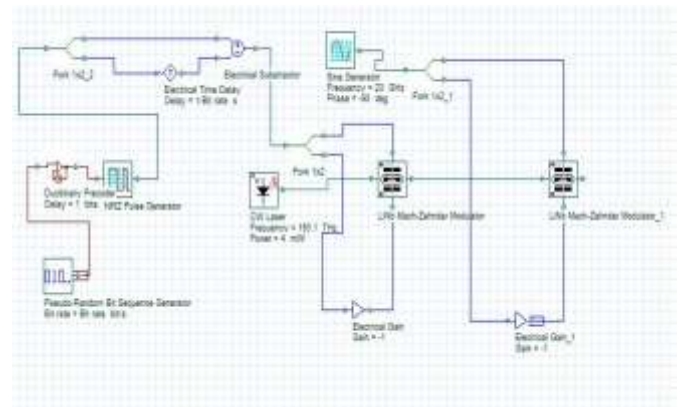

Fig .1.(e) MDRZ Modulation

Figure 1(e) shows the system transmitting MDRZ signal. The NRZ Duobinary is created by electrical time delay and electrical subtractor which is further connected with primary MZM. The second MZM is connected with the sine generator.



III. PROPOSED SYSTEM

IV. RESULTS AND DISCUSSION

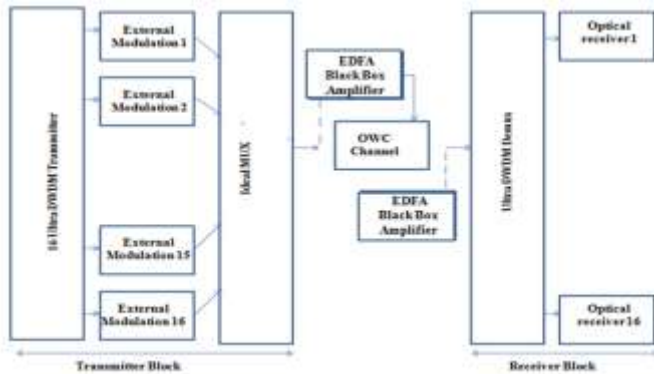

Fig .2. Simulation setup the proposed 16-channel OWC system

Fig. 2 demonstrates the simulation setup of 16-channel ultra DWDM system. The simulation result is achieved with five modulation formats i.e. RZ, NRZ, CSRZ, DRZ, MDRZ in various electromagnetic band wavelength at 10 Gbps. The OWC channel range is 2500 Km. The schematic diagram comprises of three fundamental pieces i.e. Transmitter, Wireless transmission, Receiver. The transmitter part contains 16 ultra DWDM transmitter, divergent modulation formats and an ideal MUX. The transmission block involves OWC channel and two EDFA black box amplifiers. The Receiver part involves DEMUX and optical receivers. The optical receiver consists of a PIN photodiode and filter. Eye diagram analyzer is used to calculate the Q factor and BER which is connected at the end of receiver.

The specifications of the proposed IS-OWC system are written in Table 1.

Table1. Simulation Parameters of the proposed system

S. No.	Parameter	Value/ Type
1.	Input Power (dBm)	10,20,30
2.	Ultra DWDM channel spacing	25 GHz
3.	Range of OWC	2500 Km
4.	Channel Wavelength	750 nm- infra high capacity 280 nm- ultra high capacity 390 nm- Visible high capacity
5.	Data Rate	10 Gbps
6.	Modulation formats	RZ,NRZ,CSRZ,DRZ,MDRZ
7.	Amplifier used	EDFA Black box Amplifier

The simulation work is done by utilizing Optisystem 14.0. Q factor and BER for all the modulations is calculated for different electromagnetic band wavelengths i.e. ultra violet, infrared and visible ranges. The most extreme Q factor is 14.112 acquired for CSRZ at 10 Gbps bit rate, in ultra violet wavelength region. The comparison of the outcomes for various modulation formats in various range is shown in Table 2(a) - 2(c).

Table 2(a). Infra high capacity range: 750 nm wavelength, 2500 Km Distance

Parameters	Q Factor	BER
RZ	9.86912	1.92698e-023
NRZ	5.05324	1.59705e-007
DRZ	5.38926	2.1687e-039
MDRZ	4.01888	1.8406e-005
CSRZ	13.0742	1.82228e-039

Table 2(b). ultra high capacity range: 280 nm wavelength, 2500 Km Distance

Parameters	Q Factor	BER
RZ	10.0955	2.02004e-024
NRZ	5.13408	1.04954e-007
DRZ	5.49575	1.22178e-008
MDRZ	4.08394	1.38028e-005
CSRZ	14.112	1.28518e-045

Table 2(c). Visible high capacity range: 390 nm wavelength, 2500 Km Distance

Parameters	Q Factor	BER
RZ	9.8741	1.90632e-023
NRZ	5.10176	1.27215e-007
DRZ	5.49757	1.21108e-008
MDRZ	4.00124	2.0617e-005
CSRZ	13.7747	1.45618e-043

Fig. 3(a)–(c) demonstrate the greatest Q factor versus the input power for various modulation formats in various wavelength ranges i.e. infrared, visible and ultraviolet wavelengths at 10 Gbps bit rate and distance of 2500 Km.

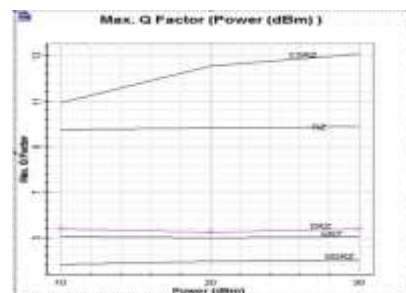

Fig.3. (a)infrared wavelength range

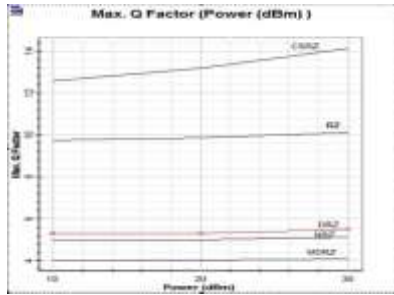

Fig.3. (b)ultraviolet wavelength range

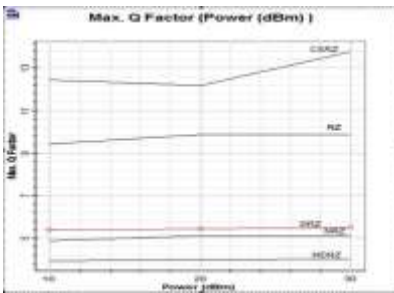
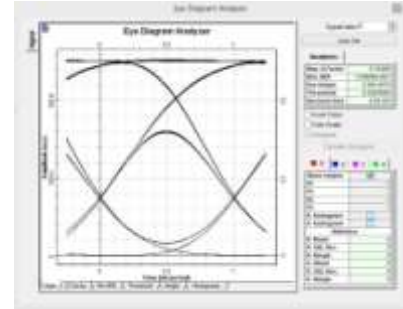
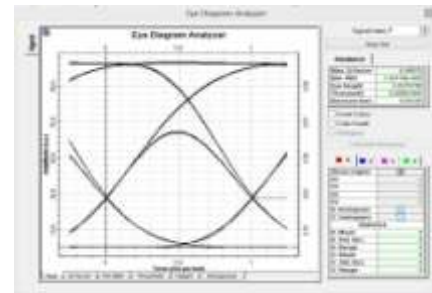

Fig.3. (c)infrared wavelength range



(b)



(c)

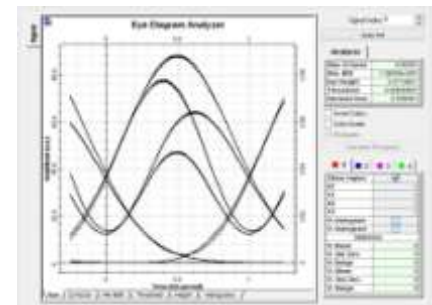

(d)

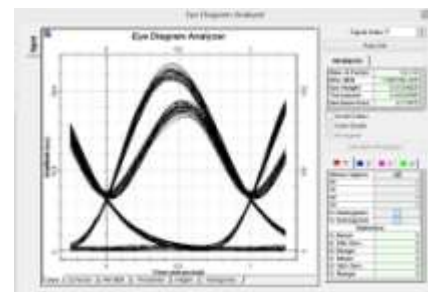

(e)

Fig. 3 Comparison of different modulation formats in (a) Visible range (b) Ultra violet range (c) infrared range

CSRZ is better than all other modulation formats. It shows higher value of Q factor in all the three ranges i.e. ultra, visible and infra range. Out of these ranges the value of Q factor is maximum in case of ultra violet range (10- 400 nm). Its value is 14.112 which is maximum than infrared and visible ranges.

Fig. 4 (a)–(e) demonstrate the eye diagram for RZ, NRZ, CSRZ, DRZ, and MDRZ modulations in ultra wavelength range. The greatest Q factor is 14.112 in fig. 4(e) for CSRZ modulation.

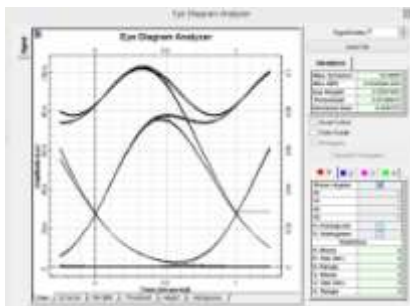

(a)

Fig.4. Eye diagram and Q factor of ultra range in (a) RZ (b) NRZ (c) DRZ (d) MDRZ (e) CSRZ



V. CONCLUSION

In this paper, infrared, ultra violet and visible inter-satellite OWC systems are compared with distinctive modulation formats RZ, NRZ, DRZ, CSRZ, MDRZ at 10 Gbps. The relative investigations demonstrate the maximum value of Q factor and least BER at 10 Gbps in ultra high limit for the proposed system. The Q component of ultra high limit range is 14.112 which is greatest than other limit ranges. The Q factor of ultra violet range is 7.94% more efficient than infra range and 2.45% better than visible range for CSRZ.

VI. REFERENCES

- [1] N. Kumar, "Enhanced performance analysis of inter-satellite optical-wireless communication (IsOWC) system", *Optik Elsevier*, vol.125, pp.1945-1949, 2014
- [2] V. Sharma, N. Kumar, "Modeling of 2.5 Gbps-Intersatellite link (ISL) in inter-satellite optical wireless communication system", *Optik Elsevier*, vol.124, pp.6182-6185, 2013
- [3] A.H Hashim, "Modeling and performance study of inter satellite optical wireless communication system", *International conference on Photonics (ICP), IEEE*, pp.1-4, 2010
- [4] A. Alipour, A. Mir, "Ultra high capacity inter satellite optical wireless communication system using different optimized modulation formats", *Optik Elsevier*, vol.127, pp. 8135-8143, 2016
- [5] P. Kaur, A. Gupta, "Comparative analysis of Inter satellite Optical Wireless Channel for NRZ and RZ modulation formats for different levels of input power", *ScienceDirect Elsevier*, vol.58, pp.572-577, 2015
- [6] P. Kaur, B. Utreja, "Performance Analysis of Advanced Modulation Formats in Inter-Satellite Optical Wireless Communication System", *International Journal of Computer Science & Engineering Technology*, vol.5, Issue 6, pp.146-148, 2015
- [7] R. Kaur, S. Dewra, "Duobinary Modulation Format for Optical system- A Review", *International Journal of Advanced Research in Electrical, Electronics and Instrumentation Engineering*, vol.3, Issue 8, pp.11040-11046, 2014
- [8] N. Kaur, G. Soni, "Performance analysis of inter-satellite optical wireless communication (IsOWC) system by using NRZ and RZ modulation", *International Journal of Scientific and Research Publications*, vol.5, Issue 1, pp. 125-130, 2015
- [9] K. Singh, M. Bhamrah, "Investigations of transmitted power in Intersatellite Optical Wireless Communication", *International Journal of Computer Science and Information Technology & Security*, vol.2, No.3, pp.568-573, 2012
- [10] P. Sharma, S. Shrivastava, "Designing and Performance Evaluation of IsOWC System using Mach-Zehender Modulator", *International Journal of Science and Research*, vol.5, Issue 4, pp.2316-2320, 2016
- [11] P. Kaur, S. Kaur, "Comparative analysis between NRZ and RZ coding of WDM system", *International Journal of Advanced Research in Computer and Communication Engineering*, vol.5, Issue 6, pp.214-218, 2016